

420-0041UK  
2nd PRINTING



## SEGA AMUSEMENTS INTERNATIONAL LTD.

42 Barwell Business Park, Leatherhead Road  
Chessington, Surrey  
KT9 2NY  
United Kingdom

Telephone: +44 (0) 208 391 8090 Facsimile: +44 (0) 208 391 8099  
Email: sales@segaarcade.com Web: <http://www.segaarcade.com>

© Kaizen Entertainment

**Errors & Omissions Excepted (E&OE)**

ZOMBIES READY DEADY GO!

OWNER'S MANUAL

420-0041UK



## SERVICE MANUAL



### IMPORTANT

- Before using this product, read this Manual carefully to understand the contents herein stated
- After reading this Manual, be sure to keep it near the product or in a convenient place for easy reference when necessary

# BEFORE USING THE PRODUCT, BE SURE TO READ THE FOLLOWING:

## TO MAINTAIN SAFETY:

To ensure the safe operation of this product, be sure to read the following before usage:

The following instructions are intended for the users, operators and the personnel in charge of the operation of the product. After carefully reading and sufficiently understanding the warning displays and cautions, handle the product appropriately. Be sure to keep this manual close to the product or in a convenient place for future reference.

Herein, explanations which require special attention are enclosed with dual lines. Depending on the potentially hazardous degrees, the terms of "**DANGER**", "**WARNING**", "**CAUTION**", etc. are used.

Be sure to understand the contents of the displays before reading the text.

## PICTOGRAPHS AND DEFINITIONS

 **DANGER** Indicates that mishandling the product by disregarding this pictograph will cause severe injury or death.

 **WARNING** Indicates that mishandling the product by disregarding this warning will cause a potentially hazardous situation which can result in death or serious injury.

 **CAUTION** Indicates that mishandling the product by disregarding this caution will cause a slight hazardous situation which can result in personal injury and/or material damage.

For the safe usage of the product, the following pictographs are used:



Indicates "**HANDLE WITH CARE.**" In order to protect the human body and equipment, this display is attached to places where the instruction Manual should be referred to



Indicates a "**protective earth terminal.**" Before operating the equipment, be sure to connect it to the ground (this step may be omitted for products in which a power cable with earth is used)

- **Perform work in accordance with the instructions herein stated:**  
Instructions for work are explained by paying attention to the aspect of accident prevention. Failing to perform work as per the instructions can cause accidents. In the case where only those who have technical expertise should perform the work to avoid hazardous situation, the instructions herein state that the site maintenance personnel should perform such work
- **Be sure to turn off the power before working on the machine:**  
To prevent an electric shock, be sure to turn off the power and unplug the power cable before carrying out any work that requires direct contact with the interior of the product. If the work is to be performed in the power-on status, the instruction manual herein always states to that effect
- **Be sure to ground the earth terminal (not required in the case where a power cable with earth is used):**  
This product is equipped with the earth terminal. When installing the product, connect the earth terminal to the "accurately grounded indoor earth terminal" by using an earth wire. Unless the product is grounded appropriately, the user can be subject to an electric shock. After performing repair, etc. for the control equipment, ensure that the earth wire is firmly connected to the control equipment
- **Ensure that the power supply used is equipped with an earth leakage breaker:**  
Using a power supply which is not equipped with the earth leakage breaker can cause a fire when earth leakage occurs
- **Be sure to use fuses which meet the specified rating (only for the machines which use fuses):**  
Using fuses that exceed the specified rating can cause a fire and an electric shock

- **Specification changes (removal of equipment, conversions and additions) not designated by SEGA are not allowed:**

The parts of the product include warning labels for safety, covers for personal protection, etc. It is very hazardous to operate the product by removing parts and/or modifying the circuits. Should doors, lids and protective parts be damaged or lost, refrain from operating the product, and contact where the product was purchased from or the office herein stated.

SEGA shall not be held responsible for any accidents or compensation for damage to a third party resulting from the specifications not designated by SEGA

- **Ensure that the product meets the requirements of appropriate electrical specifications:**

Before installing the product, check for electrical specifications. SEGA products have a nameplate on which the electrical specifications are described. Ensure that the product is compatible with the power supply voltage and frequency requirements of the location. Using any electrical specifications different from the designated specifications can cause a fire and an electric shock

- **Install and operate the product in places where appropriate lighting is available, allowing warning labels to be clearly read:**

To ensure safety for the customers, labels and printed instructions describing potentially hazardous situations are applied to places where accidents can be caused. Ensure that where the product is operated has sufficient lighting allowing the warnings to be read. If any label is peeled off, apply it again immediately. Please place an order with where the product was purchased from or the office herein stated

- **When handling the monitor, take considerable care (applies only to products with monitors):**

Some of the monitor parts are subject to high tension voltage. Even after turning off the power, some portions are still subject to high tension voltage. Monitor repair and replacement should be performed only by those technical personnel who have knowledge of electricity and technical expertise

- **Be sure to adjust the monitor properly (applies only to products with monitors):**

Do not operate the product leaving on-screen flickering or blurring as it is. Using the product with the monitor not properly adjusted may cause dizziness or a headache to an operator, a player, or customer

- **When transporting or reselling this product, be sure to attach this manual to the product**

\* *In the case where commercially available monitors and printers are used in this product, only the contents relating to this product are explained herein. Some commercially available equipment has functions and reactions not stated in this Manual. Read this Manual together with the specific instruction Manual of such equipment*

\* *Descriptions herein contained may be subject to improvement changes without notice*

\* *The contents described herein are fully prepared with due care. However, should any question arise or errors be found, please contact SEGA*

## INSPECTIONS IMMEDIATELY AFTER TRANSPORTING THE PRODUCT TO THE LOCATION

Normally, at the time of shipment, SEGA products are in a status allowing for usage immediately after transporting to the location. Nevertheless, an irregular situation may occur during transportation. Before turning on the power, check the following points to ensure that the product has been transported in a satisfactory status:

- Are there any dented portions or defects (cuts, etc.) on the external surfaces of the Cabinet?
- Are castors and adjusters damaged?
- Do the power supply voltage and frequency requirements meet with those of the location?
- Are all wiring connectors correctly and securely connected? Unless connected in the correct way, connector connections can not be made accurately. Do not insert connectors forcibly.
- Do power cables have cuts or dents?
- Are all accessories available?
- Can all doors and lids be opened with the accessory keys? Can doors and lids be firmly closed?

# READ BEFORE OPERATING

## OPERATOR NOTICE OF LEGAL REQUIREMENTS

This game is a ticket redemption game. The laws and regulations on operating ticket redemption games are different in individual states, countries and territories.

The game has settings and operator options to accommodate various levels of skill and ticket payout. Local laws, regulations and codes can impact the stake, value of ticket payout and the level of skill required to win.

Not all settings and options are suitable for every jurisdiction. In some jurisdictions, ticket redemption games are prohibited.

### **IT IS SOLELY YOUR RESPONSIBILITY AS THE OPERATOR OF THE GAME TO:**

- fully comply with laws, regulations and ticket payout value limitations in the jurisdiction where you place and offer this game to the public. (Contact your legal adviser for local advice);
- ensure that the amount of ticket payout comply with local laws (in type and value); and
- use the settings and options for play to ensure the game is operated within the local laws.

Neither the manufacturer nor distributor is responsible for any failure to operate the game in accordance with the relevant laws and regulations and has no liability for any consequences of such failure.



# INTRODUCTION

This Manual is intended to provide detailed descriptions together with all necessary information covering the general operation of electronic assemblies, electromechanical, servicing control, spare parts, etc. for the product:

**"ZOMBIES READY, DEADY, GO!"**

This Manual is intended for the owners and personnel managers in charge of operation of this product. Operate the product after carefully reading and sufficiently understanding the instructions.

In the unlikely event that the product does not function correctly, **DO NOT** allow anyone other than a technician to touch the internal system. Turn off the power to the machine, making sure to unplug the electrical cord from the outlet, and contact the office listed below or the point-of-purchase for this product.

Use of this product is unlikely to cause physical injuries or damage to property. However, points that require special attention are indicated by bold text, the words "**STOP**", "**IMPORTANT**", "**WARNING**", or "**CAUTION**" and the symbols below.

## **IMPORTANT!**

Indicates important information that, if ignored, may result in the mishandling of the product and cause faulty operation or damage to the product

## **WARNING**    **CAUTION**

Indicates a warning or caution that, if ignored, may result in the mishandling of the product and cause faulty operation or damage to the product

Sega Amusements International Limited



42 Barwell Business Park, Leatherhead Road  
 Chessington  
 Surrey, KT9 2NY  
 United Kingdom

<b>European Sales:</b>	+44 (0)208 391 8090	<b>Email:</b>	sales@segaarcade.com
<b>USA Sales:</b>	+00 (1) 224 265 4287	<b>Email:</b>	sales@segaarcade.com
<b>STS (Spare):</b>	+44 (0) 208 391 8060 (Option 1)	<b>Email:</b>	stssales@segaarcade.com
<b>Tech Support:</b>	+44 (0)208 391 8060 (Option 2)	<b>Email:</b>	technical@segaarcade.com
<b>Prize &amp; Merchandise:</b>	+44 (0)208 391 8060 (Option 1)	<b>Email:</b>	stssales@segaarcade.com

**Web:** <https://segaarcade.com/>

**SPECIFICATIONS**

**Standard Cabinet**

<b>Machine Dimensions:</b>	2.16m (85.03in) [Width] x 2.06m (81.1in) [Depth]
<b>Machine Height:</b>	2.37m (93.3in) (Installed)
<b>Machine Weight:</b>	716kg Approx (1578lbs)
<b>Power, maximum current:</b>	-752w-
<b>Rating:</b>	110-230VAC @ 50/60Hz
<b>Fuse Rating:</b>	5A (UK/EU) 8A (US)

**INDIVIDUAL SPECIFICATIONS**

**Monitor Cabinet**

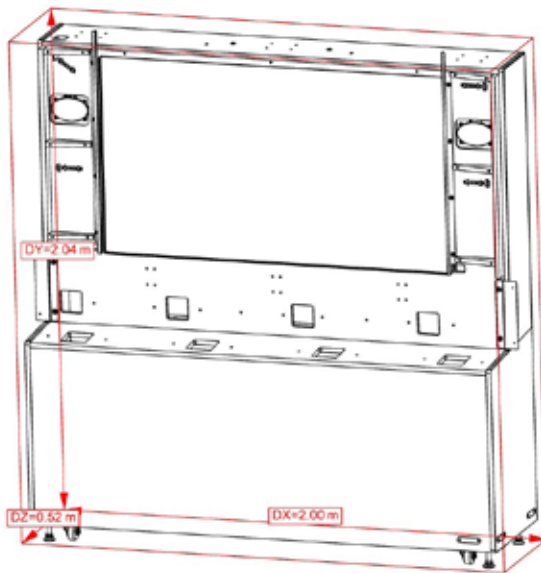

**Control Cabinet**

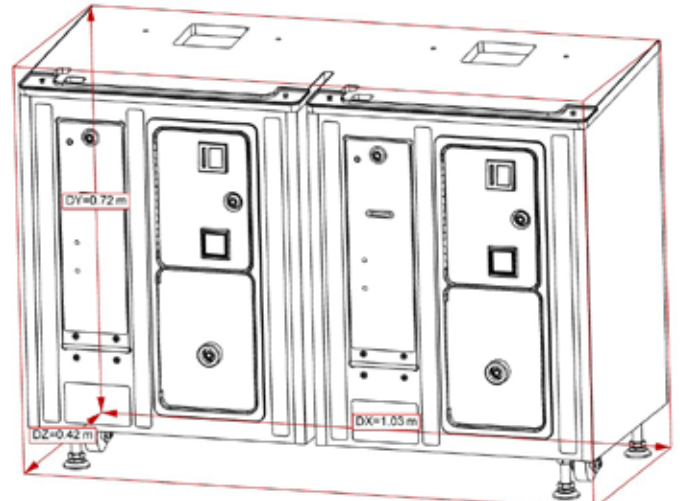

**Billboard**

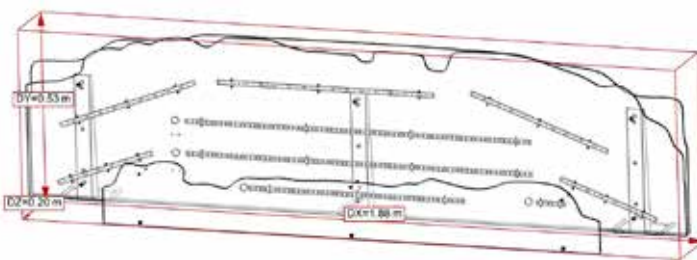

**Playdeck**

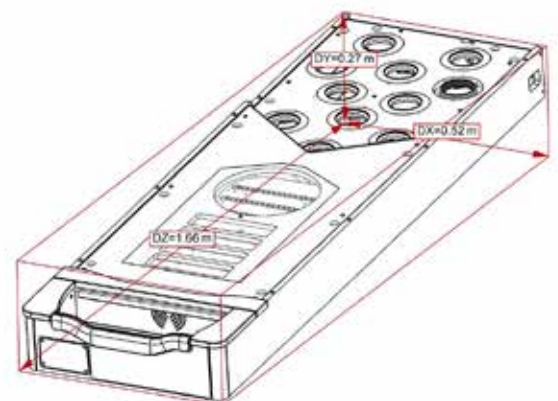



## IMPORTANT!

**Procedures not described in this Manual or marked as 'to be carried out by Site Maintenance Personnel or other qualified professionals' should not be carried out by personnel without the necessary skill or technological experience. Work carried out by unqualified persons may cause serious accidents, including electrocution**

Parts replacement, maintenance inspections, and troubleshooting should be carried out by site maintenance personnel or other qualified professionals. This Manual includes directions for potentially dangerous procedures which should only be carried out by professionals with the appropriate specialised knowledge.

The site maintenance personnel or other qualified professionals mentioned in this Manual are defined as follows:

**Site Maintenance Personnel:**

Individuals with experience in maintaining amusement equipment, vending machines, etc., working under the supervision of the owner/operator of this product to maintain machines within amusement facilities or similar premises by carrying out everyday procedures such as assembly, maintenance inspections, and replacement of units/expendable parts.

**Activities to be carried out by Site Maintenance Personnel:**

Amusement equipment/vending machine assembly, maintenance inspection and replacement of units/expendable parts.

**Other qualified professionals:**

Persons employed by amusement equipment manufacturers, or involved in design, production, testing or maintenance of amusement equipment. The individual should have either graduated from technical school or hold similar qualifications in electrical/electronics/mechanical engineering.

**Activities to be carried out by other qualified professionals:**

Amusement equipment/vending machine assembly, repair/adjustment of electrical/electronic/mechanical parts.

## Waste of Electrical and Electronic Equipment (WEEE) Statement

The WEEE (Waste of Electrical and Electronic Equipment) directive places an obligation on all EU based manufacturers and importers of Electrical and Electronic Equipment (EEE) to ensure waste equipment is disposed of in accordance with the directive at the end of their useful life.

The symbol shown below will be placed on all products manufactured from 13th August 2005, which indicates this product must NOT be disposed of with other normal waste.

**Upon purchasing any EEE from SEGA Amusements International Ltd., the user accepts responsibility to dispose of their waste equipment by arranging to return it to a designated UK collection point (AATF) or an Approved Exporter (AE) for the correct recycling of waste electrical and electronic equipment.**

For more information on Approved Authorised Treatment Facilities (AATF) within the UK please consult the government website: <https://www.gov.uk/guidance/regulations-waste-electrical-and-electronic-equipment>

For users outside of the UK, EEE should be disposed of in accordance with the local policy on the recycling of Waste Electrical and Electronic Equipment.

## Battery Recycling Statement

The EC Directive on Batteries and Accumulators (2006/66/EC) aims to minimise the impact of batteries on the environment and encourage the recovery of the materials they contain. To achieve increased collection and recycling of waste batteries, the Directive places 'producer responsibility' obligations on manufacturers and importers of portable, industrial and automotive batteries.

The symbol shown below will be on all equipment fitted with batteries from 26th September 2008 and indicates they must NOT be disposed of with other normal waste. Instead, it is the user's responsibility to dispose of used batteries by arranging to return them to a designated collection point for the correct recycling.

For more information about where you can send your waste batteries for recycling contact your local authority office.



## DECLARATION OF CONFORMITY

**Product Identification**  
 Product : ZOMBIES! READY, DEADY, GO!  
 Model : ZR-0000-XUK  
**Manufacturer**  
 Name : **SEGA AMUSEMENTS INTERNATIONAL**  
 Address : 42 Barwell Business Park  
 Leatherhead Road  
 Chessington  
 Surrey, KT9 2NY  
 Country : UK

### EMC

Name : **Kiwa Blackwood Compliance**  
 Address : Laboratory Ltd Unit 8, Woodfieldside Business Park  
 Pontllanfraith, Blackwood, Gwent  
 Country : UK  
**Standards Used** : CE  
 EN 55032:2015 + A11:2020  
 EN 55035:2017 + A11:2020  
 EN 61000-3-2:2014  
 EN 61000-3-3:2013  
**Test Report Number** : R23-6310

### LVD

Name : **Kiwa Blackwood Compliance**  
 Address : Laboratory Ltd Unit 8, Woodfieldside Business Park  
 Pontllanfraith, Blackwood, Gwent  
 Country : UK  
**Standards Used** : CE  
 EN 60335-1:2012+A15:2021\*  
 IEC 60335-1:2010+A1:2013: + A2:2016  
 EN 60335-2-82:2003+A1:2008+A2:2020\*  
 IEC 60335-2-82:2017+A1:2020\*  
**Test Report Number** : R23-6312

### RoHS

DIRECTIVE 2015/863/EU OF THE EUROPEAN PARLIAMENT AND OF THE COUNCIL on the restriction of the use of certain hazardous substances in electrical and electronic equipment

**Means of conformity.**

The product is in conformity with Directives 2014/30/EU, 2014/35/EU, 2015/863/EU in accordance with Article 10(1) of the Directive.

Signature of representative-

Date : 30/01/2024  
 Certificate Number : **SAECE-255**  
 Revision : REV 0

  
 Name : **Nigel Allison**  
 Function : **Manufacturing Director**

# TABLE OF CONTENTS

INTRODUCTION	iii
<b>1</b> HANDLING PRECAUTIONS	1
<b>2</b> PRECAUTIONS REGARDING INSTALLATION	6
<b>3</b> PRECAUTIONS REGARDING OPERATION	9
3-1 Before Operation	9
3-2 Paying Attention to Customers	11
<b>4</b> PARTS DESCRIPTION	13
<b>5</b> ACCESSORIES	14
<b>6</b> ASSEMBLY AND INSTALLATION	15
6-1 Installing the Monitor Cabinet	19
6-2 Installing the Billboard	26
6-3 Installing the Super Bonuses	31
6-4 Installing Playdecks 3 & 4 (Green & Red)	33
6-5 Installing Playdecks 1 & 2 (Blue & Pink)	41
6-6 Super Bonus Test	54
6-7 Installing Closing Plates & Panels	56
6-8 Installing the Glass Panels	58
6-9 Securing Cabinet	61
6-10 Confirmation of Installation	65
6-11 Components that change state upon powering up	66
6-12 Replacing Tickets	67
6-13 Card Reader Installation	68
<b>7</b> PRECAUTIONS WHEN MOVING	72
7-1 Precautions of the Machine	72
7-2 Moving the Machine	74
<b>8</b> GAME DESCRIPTION	75
8-1 Game Outline	75
8-2 Foul States	78
8-3 Error Codes	78
<b>9</b> TEST AND SERVICE DATA	79
9-1 Switch and Coin Meter	80
9-2 Game Test Mode	81
9-3 System Information	82
9-4 Input Test	83
9-5 Input Opto Test	84
9-6 Output Test	85
9-7 Coin Test	86
9-8 Sound Test	87
9-9 Screen Test	88
9-10 Bookkeeping	89
9-11 Clock Test	94
9-12 Game Assignments	95
9-13 Error Page	96
<b>10</b> VIDEO DISPLAY	97
10-1 General Description	97
10-2 Cleaning the Screen	99
10-3 On-Screen Adjustment Method	100
10-4 Monitor Troubleshooting	103



<b>11</b>	<b>COIN HANDLING</b>	<b>107</b>
	11-1 Cleaning the Coin Selector	107
	11-2 Fault Finding	110
	11-3 Adjusting the Price of Play (Excel)	111
	11-4 Coin Region & Price of Play Settings	112
	11-5 Price of Play Quick Start (USA)	113
<b>12</b>	<b>LAMPS AND LIGHTING</b>	<b>115</b>
	12-1 Coin Door Lamp	115
	12-2 Cabinet LED List	116
	12-3 LED Diagrams	117
<b>13</b>	<b>PERIODIC INSPECTION</b>	<b>121</b>
<b>14</b>	<b>TROUBLE SHOOTING</b>	<b>123</b>
	14-1 Troubleshooting (No Error Message)	123
<b>15</b>	<b>GAME BOARD</b>	<b>126</b>
	15-1 How to Remove Game Board	127
<b>16</b>	<b>DESIGN RELATED PARTS</b>	<b>129</b>
<b>17</b>	<b>PARTS LIST</b>	<b>130</b>
<b>18</b>	<b>COLOUR CODE</b>	<b>162</b>
<b>19</b>	<b>SCHEMATIC DIAGRAM</b>	<b>163</b>

# 1 HANDLING PRECAUTIONS

When installing or inspecting the machine, be mindful of the following points and pay attention to ensure that the player can enjoy the game safely.

Noncompliance with the following points or inappropriate handling running counter to the cautionary matters herein stated can cause personal injury or damage to the machine.

## WARNING

- Before performing work, be sure to turn the power off. Performing the work without turning the power off can cause an electric shock or short circuit. In cases where work should be performed in the status of power on, this Manual always states to that effect
- To avoid an electric shock or short circuit, do not plug in or unplug quickly
- To avoid an electric shock, do not plug in or unplug with a wet hand
- Do not expose power cords or earth wires on the surface, (floor, passage, etc). If exposed, the power cords and earth wires are susceptible to damage. Damaged cords and wires can cause an electric shock or short circuit
- To avoid causing a fire or an electric shock, do not put things on or damage the power cords
- During or after installing the product, do not unnecessarily pull the power cord. If damaged, the power cord can cause a fire or an electric shock
- In the case that the power cord is damaged, ask for a replacement through where the product was purchased from or the office herein stated. Using the cord as is damaged can cause fire, an electric shock or leakage
- Be sure to perform grounding appropriately. Inappropriate grounding can cause an electric shock
- Be sure to use fuses meeting the specified rating. Using fuses exceeding the specified rating can cause a fire or an electric shock
- Be sure that connections such as IC Board are made properly. Insufficient insertion can cause an electric shock
- Specification changes, removal of equipment, conversion and/or addition, not designated by SEGA are not permitted
- Failure to observe this may cause a fire or an electric shock. Noncompliance with this instruction can have a bad influence upon the physical conditions of players or onlookers, or result in injury during play
- SEGA shall not be held responsible for damage or compensation for damage to a third party caused by specification changes not designated by SEGA
- Do not perform any work or change parts not listed in this Manual. Doing so may lead to an accident
- If you need to perform any work not listed in this Manual, request work from the office indicated in this Manual or the point of purchase, or inquiries for details. Be sure to perform periodic maintenance inspections herein stated

## **WARNING**

- Do not touch undesignated places. Touching places not designated can cause electric shock or short circuit
- Whenever any fasteners (e.g. screws, nuts) have been lost, be sure to use replacement fasteners with proper dimensions as specified in this Manual. If fasteners of any other dimensions are used, it could cause damage and/or separation of parts that result in secondary accidents
- Specification changes, removal of equipment, conversion and/or addition, not designated by SEGA are not permitted
- Failure to observe this may cause a fire or an electric shock. Noncompliance with this instruction can have a bad influence upon the physical conditions of players and onlookers, or result in injury during play
- SEGA shall not be held responsible for damage or compensation for damage to a third party caused by specification changes not designated by SEGA
- Performing work or parts replacements not described in this Manual could result in accidents. If you need to perform any work not listed in this Manual, request work from the office indicated in this Manual or the point-of-purchase, or inquires for details
- Be sure to perform periodic maintenance inspections herein stated

## **IMPORTANT!**

- For the IC board circuit inspections, only the use of a logic tester is recommended. Using a Multi-Tester or General Purpose Tester may result in damage to IC Circuits
- Static electricity from your body may damage some electronic devices on the IC board. Before handling the IC board, touch a grounded metallic surface so that the static electricity can be discharged
- Some parts are not designed or manufactured specifically for this game machine. The manufacturers may discontinue or change the specifications of such general-purpose parts. If this is the case, SEGA cannot repair or replace a failed game machine whether or not a warranty period has expired

## CONCERNING THE STICKER DISPLAY

This SEGA product has stickers attached describing the product manufacture No. (Serial No.) and Electrical Specifications. It also has a Sticker describing where to contact for repair and for purchasing parts.

When inquiring about or asking for repairs, **mention the Serial No. and Name of Machine indicated on the Sticker.**

The Serial Number indicates the product register. Identical machines could have different parts depending on the date of production. Also, improvements and modifications might have been made after the publication of this Manual.

**In order to ensure you order the correct parts, mention the Serial No. when contacting the applicable places.**

## CONCERNING WARNING DISPLAYS

This SEGA product has warning displays on stickers, labels and/or printed instructions adhered/attached to or incorporated in the places where a potentially hazardous situation could arise. The warning displays are intended for accident prevention for customers and for avoiding hazardous situations relating to maintenance and servicing work.

Some portions of the Cabinet contain high voltage and may cause accidents if touched. When performing maintenance, be very careful of the warning displays. It is especially important that any complex repair and replacement work not mentioned herein should be performed by those technical personnel who have knowledge of electricity and has technical expertise.

In order to prevent accidents, caution any customer ignoring the warnings to cease and desist immediately.

**1 HANDLING PRECAUTIONS**

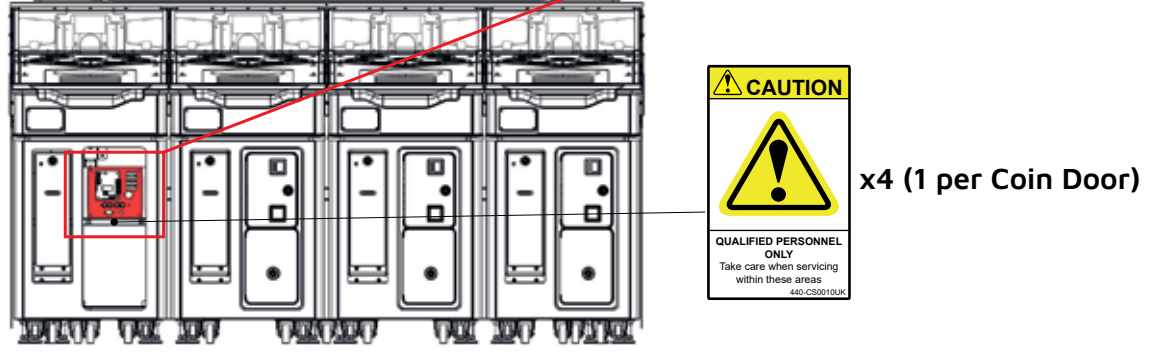
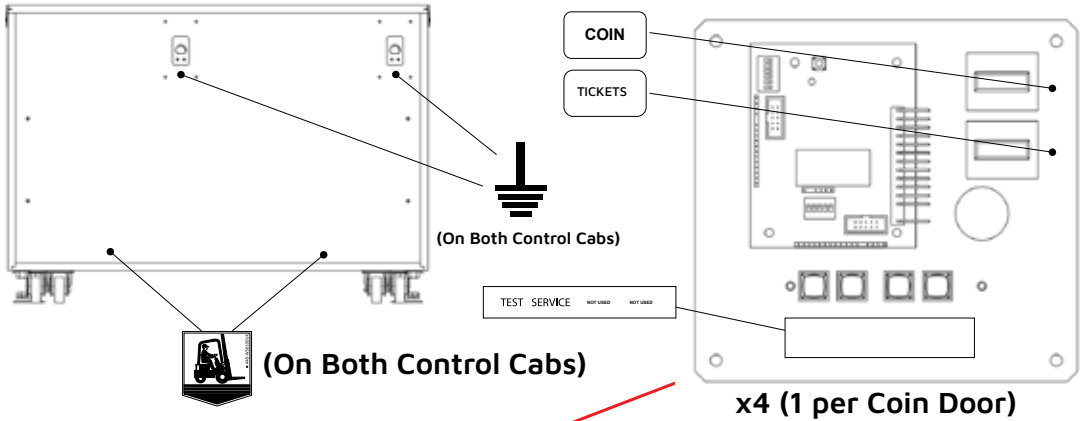
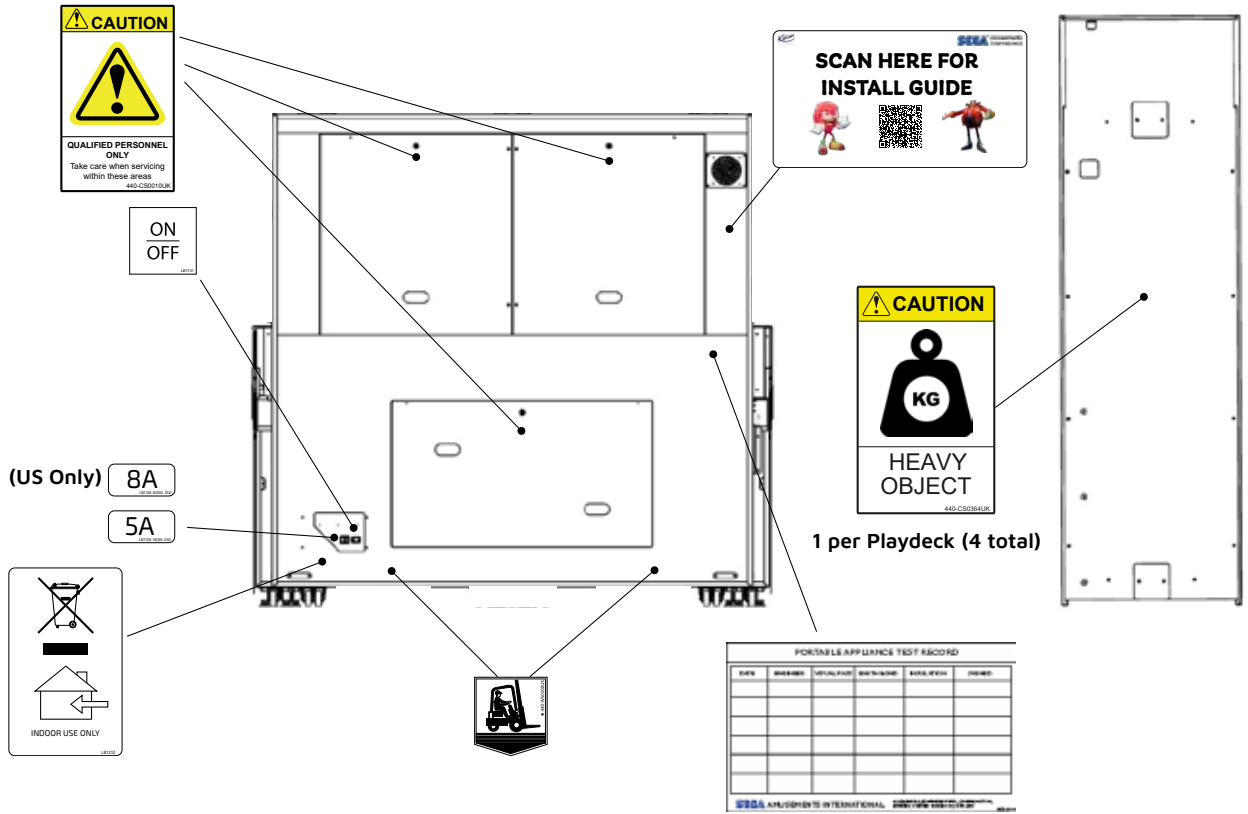

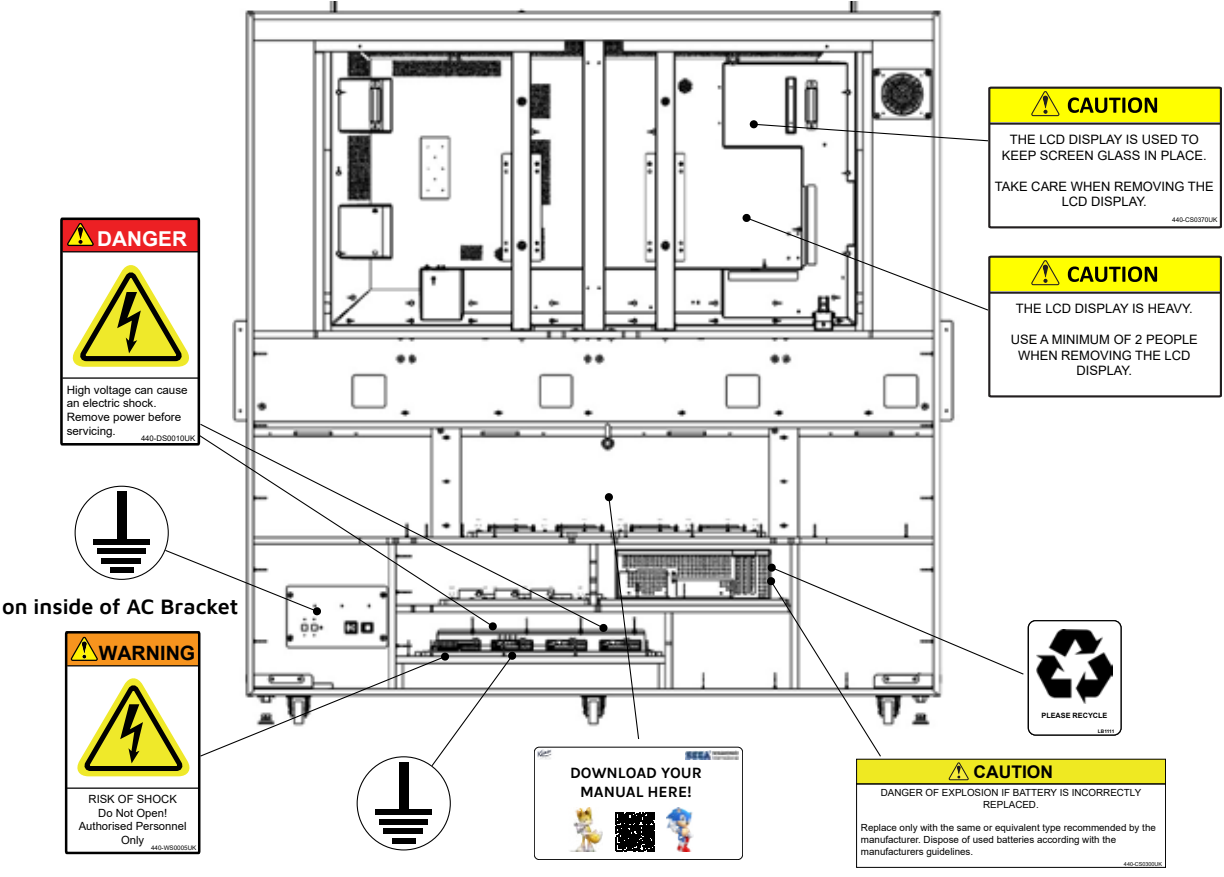
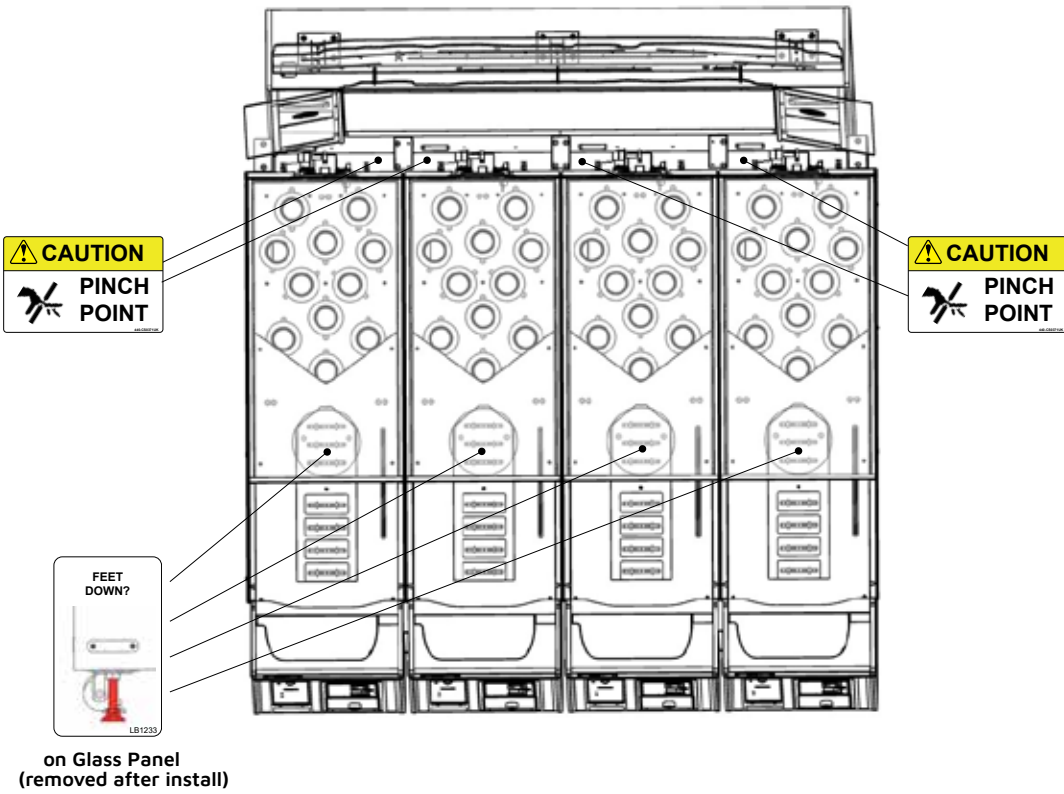



## 2 PRECAUTIONS REGARDING INSTALLATION

### WARNING

- This product is an indoor game machine. Do not install it outside. Even indoors, avoid installing in places mentioned below so as not to cause fire, electric shock, injury and/or malfunction:
- Places subject to rain/water leakage or places subject to high humidity, in the proximity of an indoor swimming pool and/or shower, etc
- Places subject to direct sunlight or places subject to high temperatures, in the proximity of heating units, etc
- Places filled with inflammable gas or vicinity of highly inflammable/volatile chemicals or hazardous matter
- In dusty places or locations prone to heavy dust accumulation
- On sloped or uneven surfaces
- Places subject to any type of violent impact
- Vicinity of anti-disaster facilities such as fire exits and fire extinguishers
- Areas where the temperature exceeds the applicable temperature (ambient temperature) range of 5 to 30 degrees centigrade

### 2-1 LIMITATIONS OF USAGE

### WARNING

- Be sure to check the Electrical Specifications. Ensure that this product is compatible with the location's power supply, voltage, and frequency requirements. A plate describing Electrical Specifications is attached to the product. Noncompliance with the Electrical Specifications can cause a fire and electric shock
- This product requires a Breaker and Earth Mechanism as part of the location facilities. Using the product without these can cause a fire and electric shock
- Ensure that the indoor wiring for the power supply is rated at 15 A or higher (AC single phase 100 V ~ 120 V area), and 7 A or higher (AC 220 V ~ 240 V area). Noncompliance with the Electrical Specifications can cause a fire and electric shock
- Be sure to use an independent power supply equipped with an Earth Leakage Breaker. Using a power supply without an Earth Leakage Breaker can cause an outbreak of fire if a power surge occurs
- Putting many loads on one electrical outlet can cause generation of heat and a fire resulting from overload
- When using an extension cord, ensure that the cord is rated at 15 A or higher (AC 100 V ~ 120 V area) and 7 A or higher (AC 220 V ~ 240 V area). Using a cord rated lower than the specified rating can cause a fire and electric shock



# IMPORTANT!

- Securing a safe area for operation as described in this Manual will ensure safe operation for players and observers
- SEGA shall not be held responsible for damage or compensation for damage to a third party, resulting from the failure to observe this instruction

## 2-2 OPERATION AREA

### WARNING

- For safe operation, use and operate this product in an area measuring at least **2.86m (112.6in)** in width and **2.76m (108.7in)** in depth when the Cabinet is installed. SEGA shall not be held responsible for damage or compensation for damage to a third party, resulting from the failure to observe this instruction
- The ceiling where this product is installed must be at least **2.4m (94.5in)** high. If the ceiling is too low, the heat emitted from the product may cause it to catch on fire
- Be sure to provide the sufficient space specified in this Manual. Do not allow objects to block the ventilation ports. This can cause generation of heat and a fire
- Put the Cabinets close together so that people cannot get through or provide enough space between them that people can go both ways without difficulty. If the Cabinets are installed carelessly, people may bump into each other or the Cabinets when passing between them or fall down. To prevent people from walking between them, place them 0.15 m (5.9 in) apart
- If the machine does not fit through the entryway to the installation location, do not disassemble it without first consulting the instructions. Specific tools and adjustment procedures are required to assemble and disassemble the mechanical parts
- Attempting to assemble or disassemble the machine without consulting the instructions may result in accidents during assembly/disassembly, electric shock, short circuits, and/or personal injury during operation. If the machine still does not fit through the entryway after following the procedures in this Manual, contact your retailer or the office listed in this Manual
- If the machine is still too large to fit through the entryway after following the procedures listed in this Manual, do not tip the machine on its side. Attempting to transport the machine while it is tipped on its side may cause accidents. It may also damage or warp parts of the machine, resulting in accidents during operation

## ⚠ WARNING

- To install this product, the entrance must be at least **0.55m (21.7in)** in width and **1.9m (74.8in)** in height without Assy Billboard and **2.4m (94.5in)** with Assy Billboard
- If the entrance is too narrow, do not tilt the product carelessly. If all the product weight is put on the castors at one side only, there could be damage or deformation, causing serious accidents such as workers getting caught underneath

Rear Wall

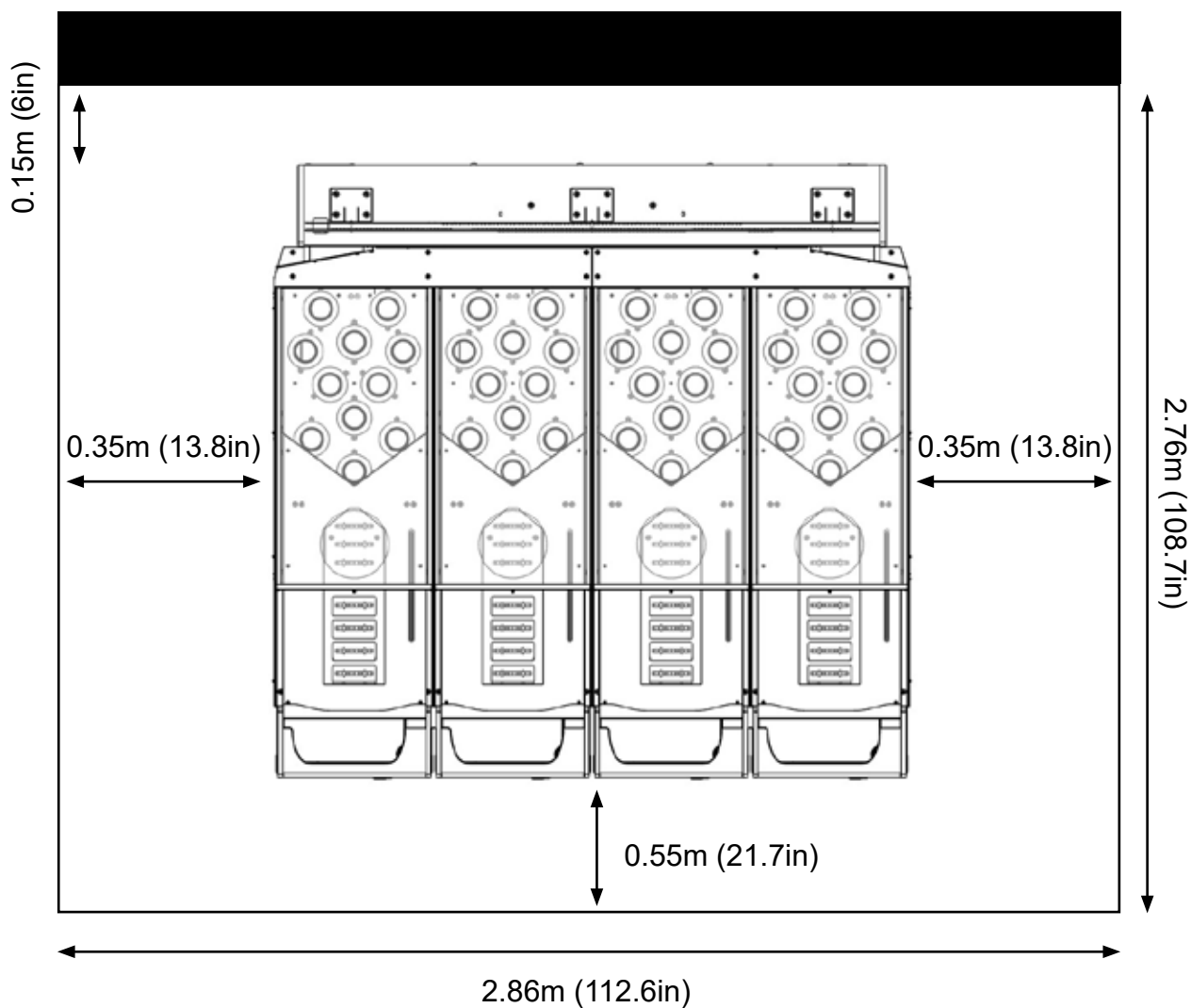

### **3 PRECAUTIONS REGARDING OPERATION**

To avoid injury and trouble, be sure to pay attention to the behaviour of visitors and players.

#### **3-1 BEFORE OPERATION**

##### **WARNING**

- In order to avoid accidents, check the following before starting the operation:
- To ensure maximum safety for the players and the customers, ensure that where the product is operated has sufficient lighting to allow any warnings to be read. Operation under insufficient lighting can cause bodily contact with each other, hitting accident, and/or trouble between customers
- Be sure to perform appropriate adjustment of the display. For operation of this machine, do not leave monitors flickering or deviation as is. Failure to observe this can have a bad influence upon the players' or customers' physical conditions
- It is suggested to ensure a space allowing the players who feel sick while playing the game to take a rest
- Check if all of the adjusters are in contact with the surface. If they are not, the Cabinet can move and cause an accident
- Do not put any heavy item on this product. Placing any heavy item on the product can cause a falling down accident or parts damage
- Do not climb on the product. Climbing on the product can cause falling down accidents. To check the top portion of the product, use a step/stepladder
- To avoid electric shock, check to see if door and cover parts are damaged or omitted
- Do not place the following items on top of or near the product or hang them from the ceiling. Doing so could result in electric shock, short circuits and/or damage to the parts:
  - > Flower vases, flowerpots, cups, water tanks, cosmetics, and receptacles/containers/vessels containing chemicals and water

 **CAUTION**

- To avoid injury, be sure to provide sufficient space by considering the potentially crowded situation at the installation location. Insufficient installation space can cause contact, collisions, and/or trouble between customers
- During daily cleaning, be sure to check the surface of the Control Cab and other parts that the player touches with his/her hands for damage, cracks, or loose screws. If a player uses the machine while it is damaged, cracked, or has a loose screw, the player may become injured
- Check carefully to make sure there are no gaps in the Cabinet joints and that they are not loose. If there are gaps or looseness, players may get their hands or fingers caught, resulting in an injury
- Make sure all the doors are locked securely and they do not rattle. If the doors are not locked properly or there are gaps or rattling, players could get their fingers or hands caught
- Be sure to perform appropriate adjustment of the display. For operation of this machine, do not leave monitor's flickering or deviation as is. Failure to observe this can have a bad influence upon the players' or customers' physical conditions
- Inspect for the following items during a trial run. If there is any type of error, use the Test Mode, etc. to resolve the problem. If you continue use with an error, it can cause an accident or irreparable parts damage:
  - Is there any strangeness in the operability of the Control Cab?
  - Are there any obstructions which prevent balls being returned to Players?
  - Are there any obstructions on the Playfield?
  - Is there any improper adjustment of the LCD screen?
- Prepare a place where players can rest if they feel sick

## 3-2 PAYING ATTENTION TO CUSTOMERS

To avoid injury and trouble, be sure to constantly give careful attention to the behaviour and manner of the visitors and players.

### DURING OPERATION (PAYING ATTENTION TO CUSTOMERS)

#### **WARNING**

- For safety reasons, do not allow any of the following people to play the game:
  - Those who have high blood pressure or a heart problem
  - Those who have experienced muscle convulsion or loss of consciousness when playing video games, etc
  - Those who have neck or spinal cord problems
  - Those who are intoxicated or under the influence of drugs
  - Pregnant women
  - Those who are not in good health
  - Those who do not follow the attendant's instructions
  - Persons who disregard the product's warning displays
- Even Players who have never been adversely affected by light stimulus might experience dizziness or headache depending on their physical condition when playing the game
- Small children are especially likely to experience these symptoms. Caution guardians of small children to keep watch over them during play
- Instruct those who feel sick during play to have a medical examination
- To avoid injury from falls and electric shocks due to spilled drinks, instruct the player not to place heavy items or drinks on the product
- To avoid electric shocks and short circuits, do not allow customers to put hands, fingers or extraneous matter in the openings of the product or small openings in and around the doors
- To avoid falls and resulting injury, immediately stop the customer from leaning against or climbing on the product, etc
- To avoid electric shock and short circuit, do not allow customers to unplug the power plug without a justifiable reason
- Instruct the guardians of small children to keep watch over their children
- Children cannot sense danger. Allowing small children to get near a Player who is playing the game could result in the children being bumped, struck or knocked down





## IMPORTANT!

- Diligently clean the parts that players touch directly to ensure a pleasant game playing experience
- Inspect the coin insertion slots to make sure no foreign objects have been inserted and that they have not otherwise been tampered with as this will prevent play



## CAUTION

- Immediately stop such violent acts as hitting and kicking the product. Such violent acts can cause parts damage or falling down, resulting in injury due to fragments and falling down
- Persons other than the Player should not be allowed to touch the Cabinet during play. They may brush against or collide with the Cabinet or the player, possibly resulting in accidents
- Instruct those who feel sick during play to have a medical examination
- Immediately stop users from leaning or sitting on the Control Cab/Playdeck. Such acts can lead to injury or damage to parts or the shape of the Cabinet
- Make sure that players understand not to stand too close together when playing a 2/3/4 player game. This could lead to a Player/Players getting hit and may cause injury
- Items such as large finger rings can cause injury to the fingers while playing. Instruct Players to remove all accessories that could cause an accident before playing



## 4 PART DESCRIPTIONS



1	BILLBOARD
2	CONTROL CABINET
3	COIN DOOR
4	CHARACTER LIGHTING
5	PLAYFIELD
6	MONITOR
7	SUPER BONUS GATE
8	PLAYFIELD DIVIDER

## 5 ACCESSORIES

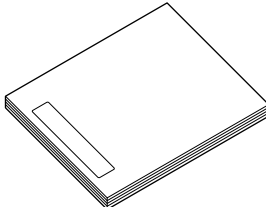
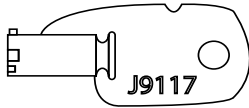
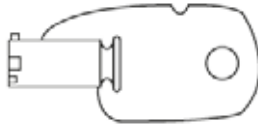
Confirm that the accessories listed in the table below are present when setting up the product. Accessories marked “Spare” are consumable items but included as spares.

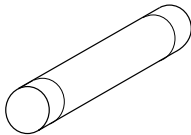
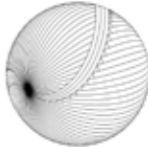
Part Name / Number	Diagram	Quantity
<b>Owner's Manual</b> (Part #: 420-0041UK)		1
<b>Master Key (J9117)</b>		16
<b>Security Key (A444)</b>		14
<b>Power Lead</b> UK (Part # LM1227) EU (Part # LM1246) US (Part # LM1504)		1ea
<b>Spare Fuse</b> (Fitted to ASSY AC UNIT)		1
BALL 60MM NYLON-WHITE		36

## **6** ASSEMBLY AND INSTALLATION

### **WARNING**

- Perform assembly work by following the procedure herein stated. Failure to comply with the instructions can cause electric shock
- Perform assembling as per this Manual. Since this is a complex machine, incorrect assembling can cause an electric shock, machine damage and/or improper functioning as per specified performance
- When assembling, more than one person is required. Depending on the assembly work, there are some cases in which working by one person alone can cause personal injury or parts damage
- Ensure that connectors are properly connected. Improper connections can cause electric shock
- Be careful not to damage the wires. Damaged wires may cause electric shock or short circuit or present a risk of fire
- This work should be carried out by site maintenance personnel or other qualified professionals. Work performed by non-technical personnel can cause a severe accident such as electric shock. Failing to comply with this instruction can cause a severe accident such as electric shock to the player during operation. If no one with proper technological expertise is available, request service from the office indicated in this document or the point of purchase so as to ensure safety
- Provide sufficient space so that assembling can be performed. Performing work in places with narrow space or low ceiling may cause an accident and assembly work to be difficult
- To perform work safely and avoid serious accident such as the Cabinet falling down, do not perform work in places where step-like grade differences, a ditch, or slope exist
- Do not leave power cords or Ground Wires exposed in areas of heavy foot traffic. Doing so may cause them to become damaged, possibly resulting in electric shock and/or short circuits. When laying wiring across the floor, always use safety covers to protect the wires. (Wiring diameter: power cable - approx.  $\varnothing$  8)
- Have a flashlight or another supplementary lighting unit available while working. With indoor lighting alone, the Cabinet interior may be too dark. Working without proper lighting can lead to accidents. It also hinders proper work performance
- The Cabinet has ventilation ports. Be sure not to block them. If they are blocked, heat can build up, leading to fire. This can also accelerate wearing of parts and malfunctions
- Secure ample ventilation space around the Cabinet. If heat builds up, there could be accidents associated with heat or smoke generation
- This product does not use any connectors other than those connected to and used by the game board when it leaves the factory. Do not needlessly connect wires to unused connectors. This could lead to overheating, generation of smoke and burn related injuries

 **CAUTION**

- Handle molded parts with care. Excessive weight or pressure may cause them to break and the broken pieces may cause injury
- To perform the operation safely and accurately you must use a safe, steady footstool or stepladder. Working without this may lead to a fall and possible injury
- When attaching or removing doors or lids, be careful that your hand or finger does not get caught in anything
- The phrase “in situ” means that fixings/brackets/parts will be pre-populated in the locations specified in the step. In most cases these fixings will need to be removed and reapplied to secure the specified parts

 **IMPORTANT!**

- Be very careful when handling the LED display screen. The screen can be damaged easily and cannot be repaired once damaged. Such damage can only be repaired by completely replacing the screen
- Be careful not to damage parts surfaces. In some cases, if such surfaces are damaged, the part must be replaced; it cannot be reinforced or repaired
- The Cabinet should not be moved as a singular unit. The Cabinet installation should be completed in the intended location of operation
- If you have to move the Cabinet within the location of operation, consult Chapter 7 - “Precautions Moving the Machine” before doing so
- Note that in some images in the installation, parts of the Cabinet have been hidden/moved in order to better show the intended process/location of parts or fixings



# IMPORTANT!

- Before commencing installation, check you have all the required parts for installation using the table below

Designation	Part Number	Part Description	QTY
1	ZR-0016UK/16XUK	SUPPORT CLOSING PLATE	2 + 1
2	ZR-0021UK	BRKT REAR INSTALL	4
3	ZR-0022UK	BRKT FRONT INSTALL	4
4	ZR-1063XUK	BRACKET CHARACTER PANEL LH	1
5	ZR-1064XUK	BRACKET CHARACTER PANEL RH	1
6	ZR-1057XUK	CHARACTER PANEL L	1
7	ZR-1059XUK	CHARACTER PANEL R	1
8	ZR-5011XUK	BRACKET REAR PANEL SUPPORT	3
9	ZR-2150XUK	ASSY SUPER BONUS	4
10	ZR-2000XUK	ASSY PLAYDECK	4
11	ZR-1013XUK	COVER FRONT CABI WIRE	4
12	ZR-2100XUK	ASSY PLAYDECK DIVIDER INNER	3
13	ZR-0007XUK	PLATE FRONT CABI LOCATING	1
14	ZR-2110XUK	ASSY PLAYDECK DIVIDER RH	1
15	ZR-2105XUK	ASSY PLAYDECK DIVIDER LH	1
16	ZR-0011XUK	BRACKET CLOSING LH	1
17	ZR-0012XUK	BRACKET CLOSING RH	1
18	ZR-0013UK	PLATE CLOSING LH	1
19	ZR-0014UK	PLATE CLOSING RH	1
20	ZR-2126UK	PANEL GLASS	4
21	ZR-2128XUK	BRACKET GLASS PANEL RETAINING	4



Designation	Fixing Description
A	M6X25 SKT BH PAS
B	M4X12 SKT BH BLACK
C	M6X40 SKT BH PAS
D	M4X25 SKT BH BLACK
E	M4X25 SKT BH PAS
F	M6X30 SKT BH PAS
G	M6X16 SKT BH PAS

Designation	Washer Description
A	M6 WSHR 20OD FLT PAS
B	M4 WSHR 16OD FLT BLK
C	M4 WSHR SPR BLK
D	M4 WSHR FORM A FLT BLK
E	M6 WSHR SPR PAS

## TOOL LIST

2mm + 2.5mm + 4mm Hex Screwdriver



PZ2 Pozidriv Screwdriver



5mm + 7mm Socket Screwdriver



## 6-1 INSTALLING THE MONITOR CAB

- 1 Place the **MONITOR CAB** into the desired installation location

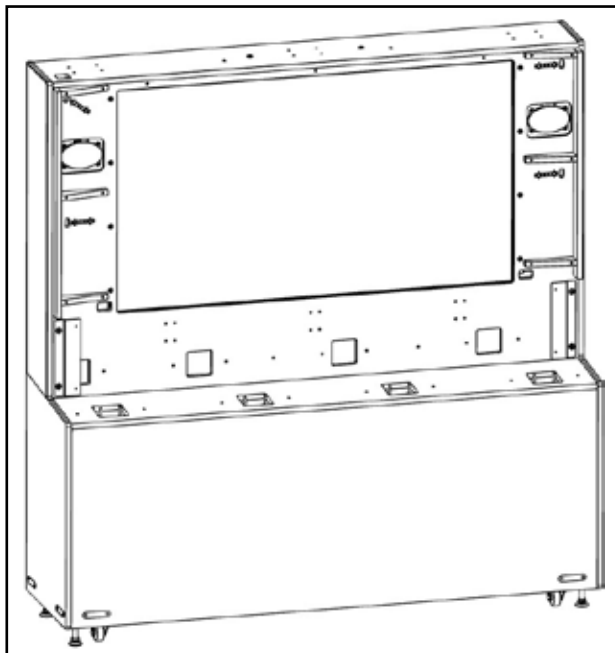

- 2 Remove the all Rear Doors on the Monitor Cab

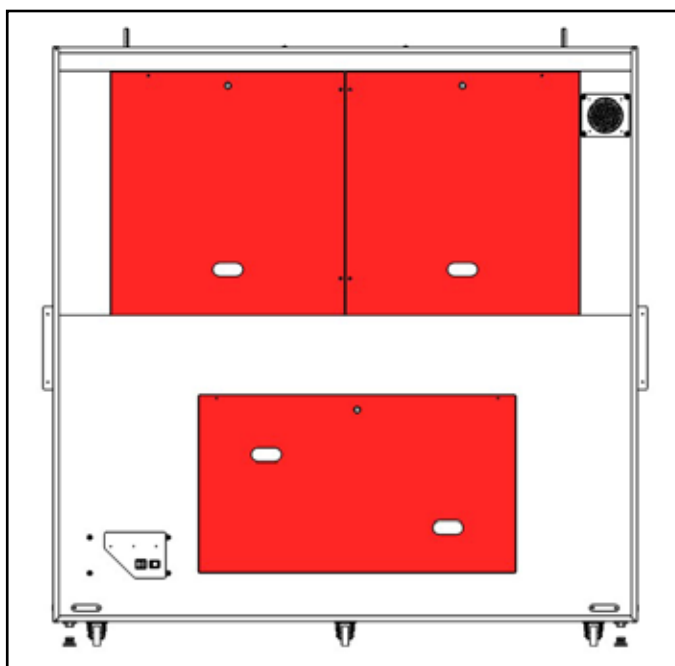

3 Remove the Monitor Cab side brackets. Rotate 180 degrees and reapply as shown

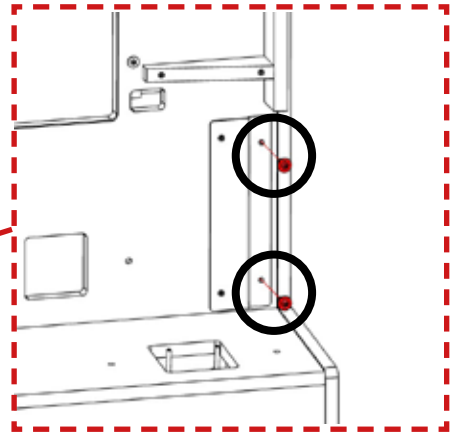
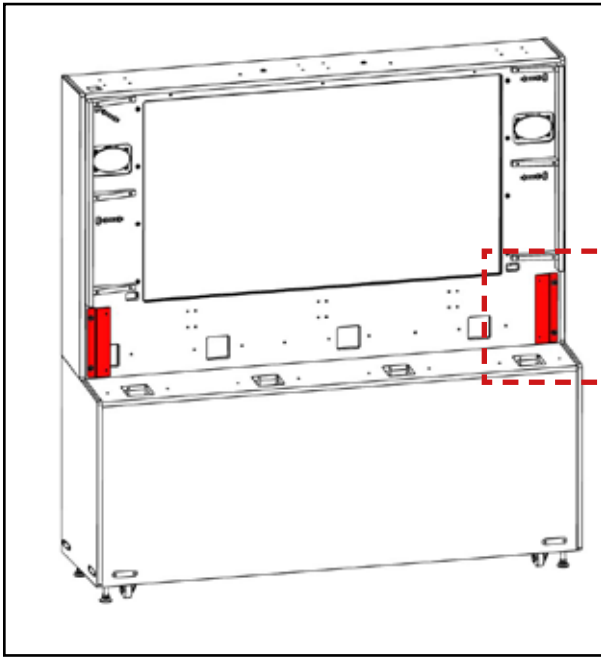

REMOVE FIXINGS

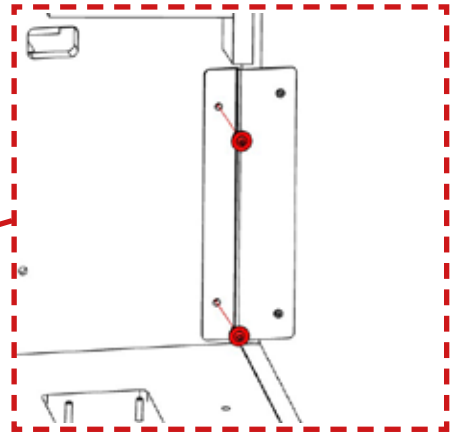
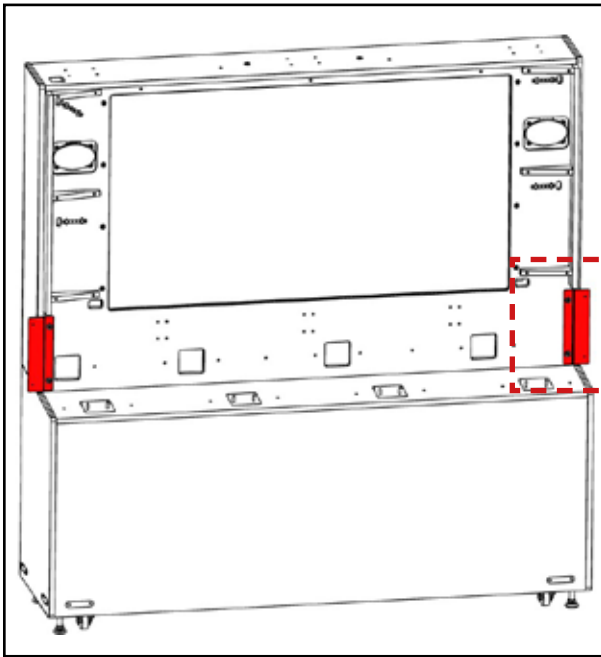
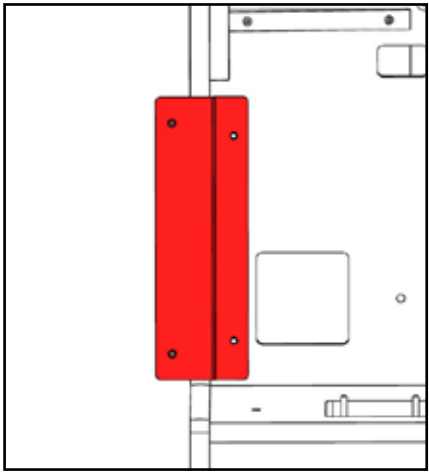
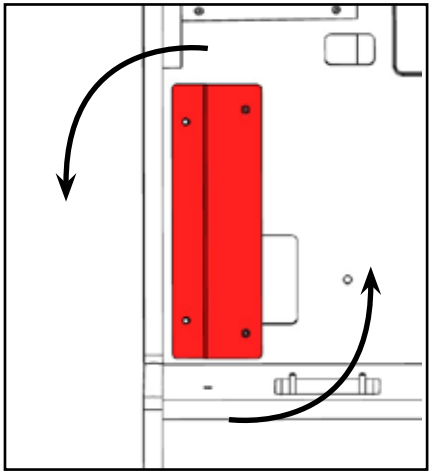

REAPPLY SAME FIXINGS

**4** Apply 3 x **PART 1** to the Monitor Cab using 2 x **FIXING A** + **WASHER A** on each Bracket

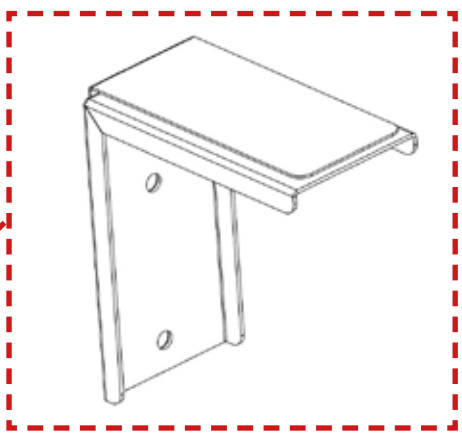
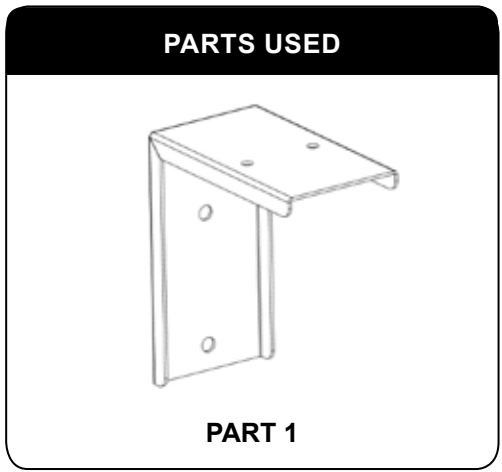

Bracket with no fixings on top goes in the middle

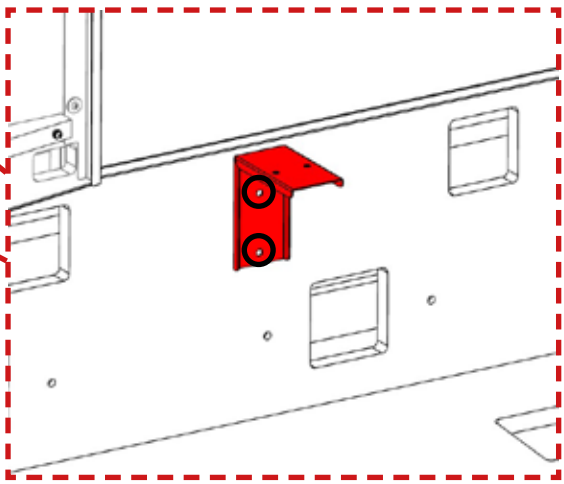
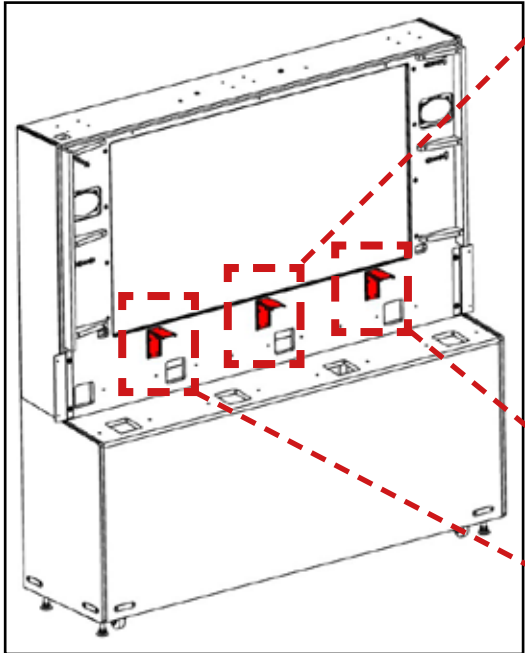

5 Apply 4 x PART 2 to the Monitor Cab and secure using 2 x FIXING F + WASHER E

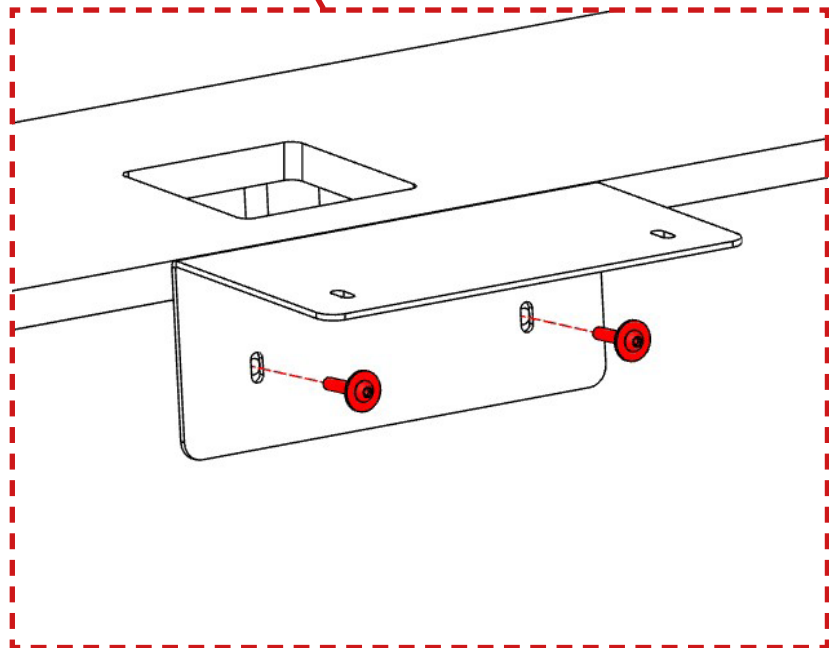
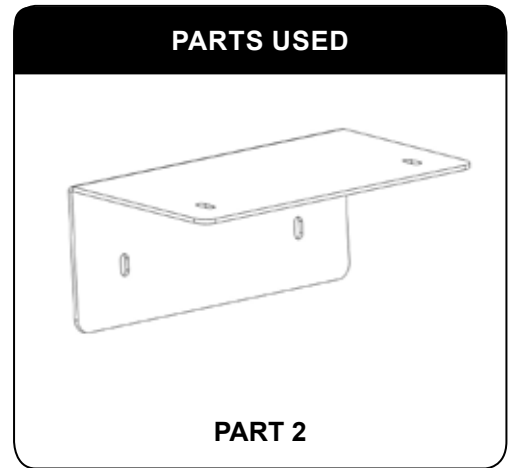
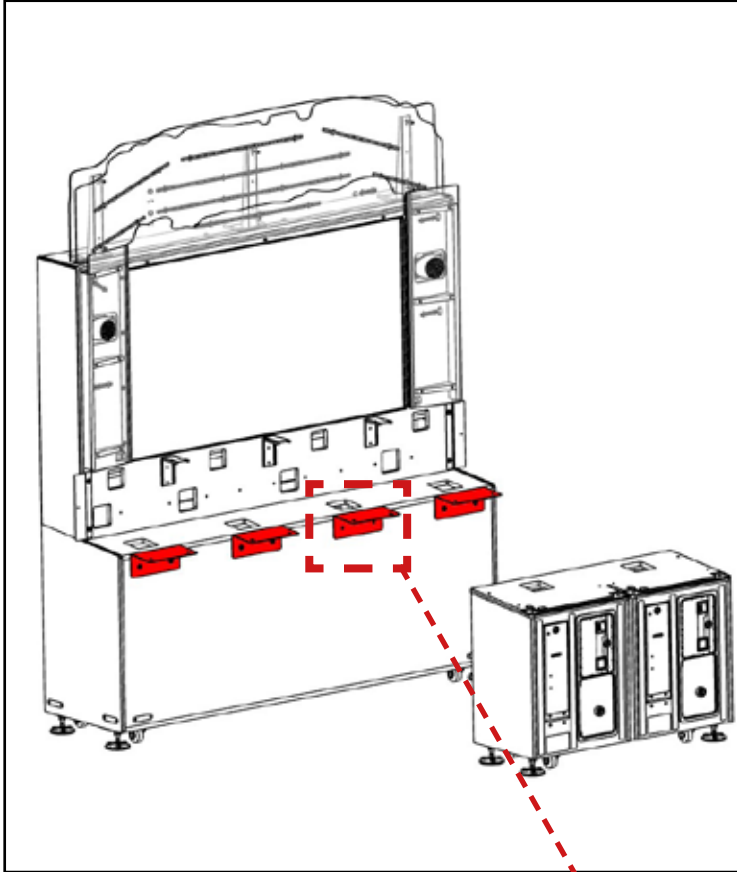

**6** Remove fixings on 2 x PART 3 on the Control Cab, rotate the Brackets, reapply and secure using 2 x FIXING F + WASHER E

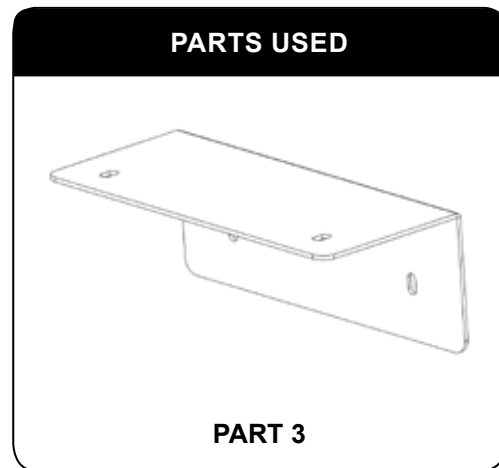
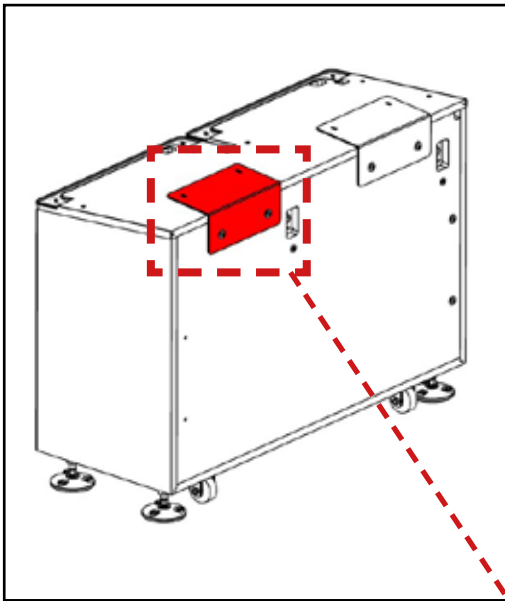

REMOVE FIXINGS AND ROTATE

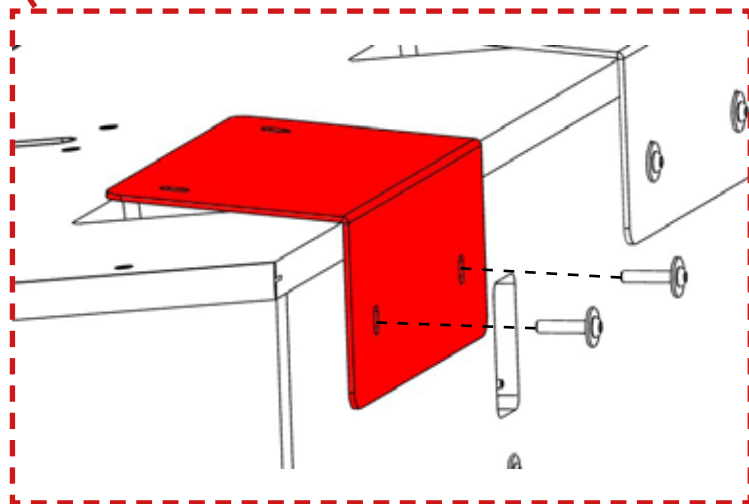

REAPPLY FIXINGS

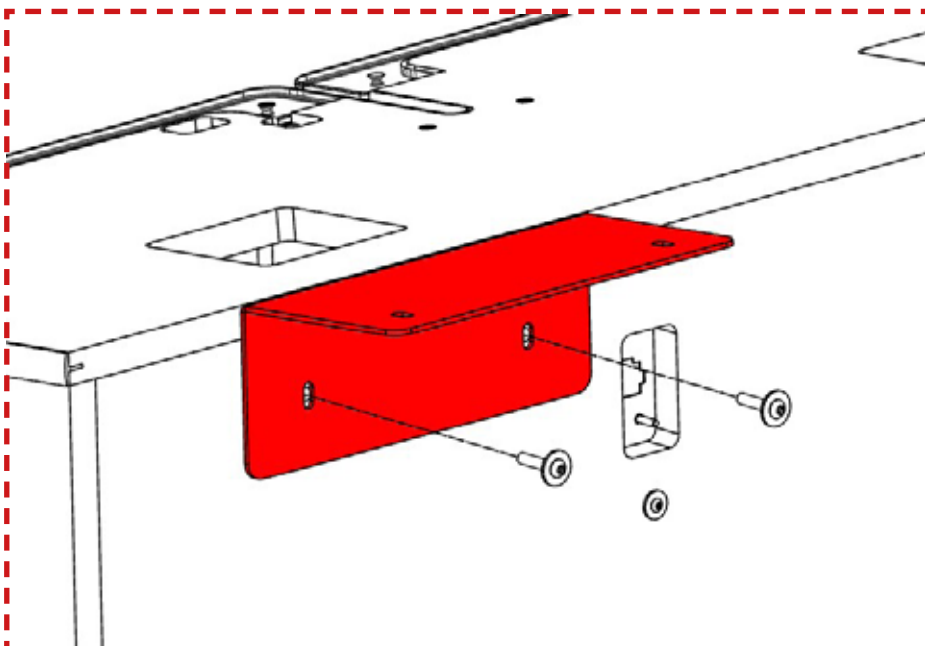

7 Install PART 4 (LEFT) & PART 5 (RIGHT) on the Monitor Cab and secure using 4 x FIXING B + WASHER B on each side

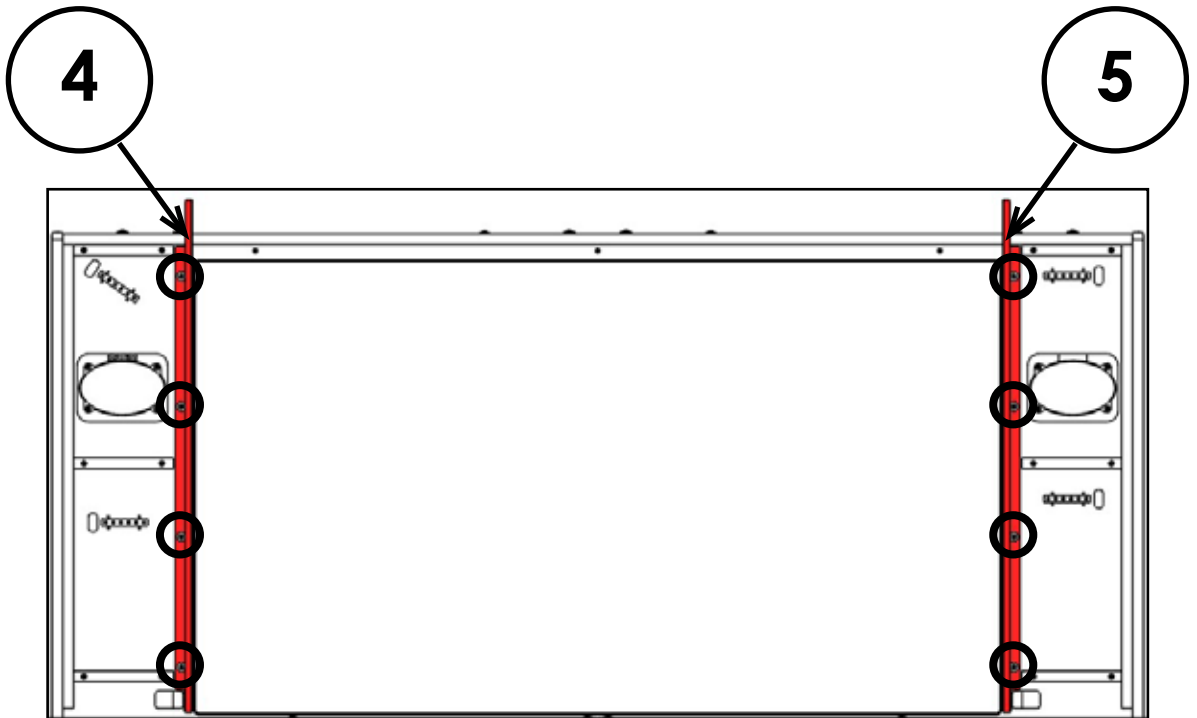
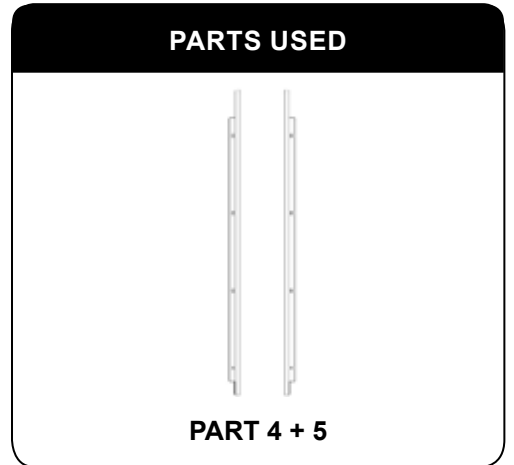
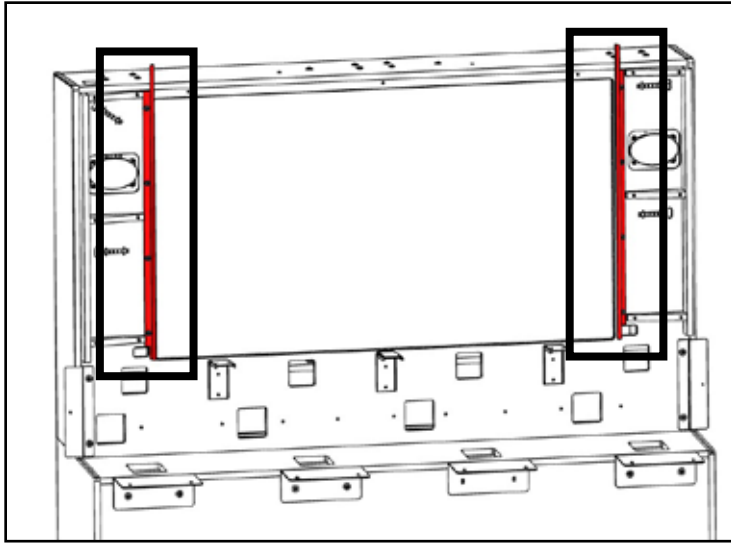

**8** Install **PART 6 (LEFT)** & **PART 7 (RIGHT)** on the Monitor Cab and secure with the 6 x **FIXING B** + **WASHER B** on each side

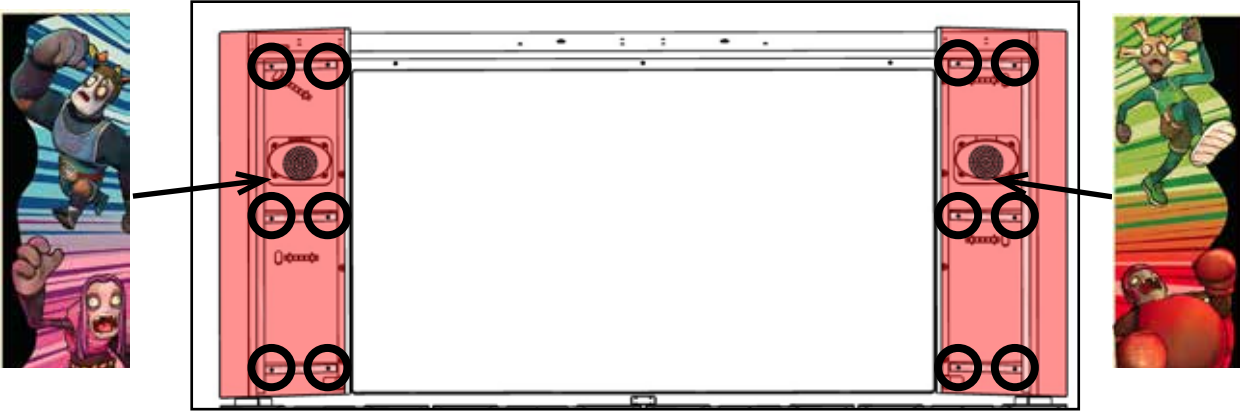

**6**

**7**

**9** Attach **Harness (PNL)** on each side

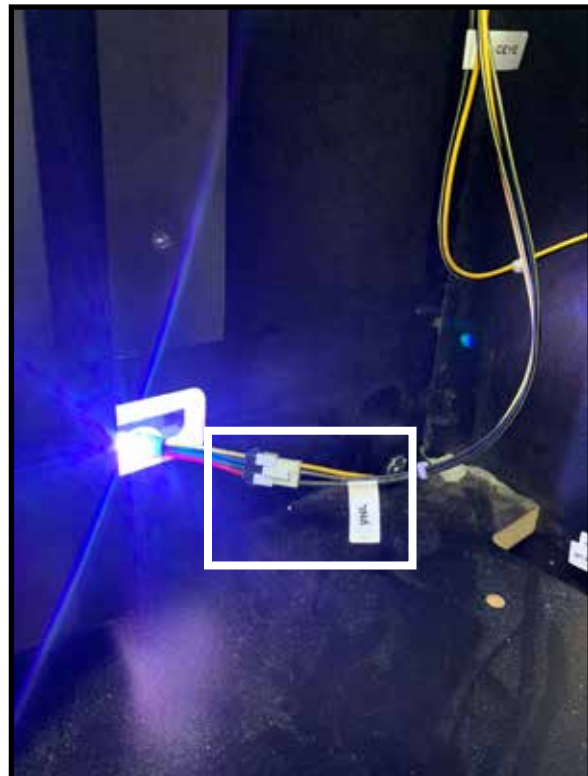



## 6-2 INSTALLING THE BILLBOARD

- 1 Apply **BACKGROUND PANEL** to the 3 x **PART 8** by applying the 3 x **FIXING B + WASHER B** on each Bracket

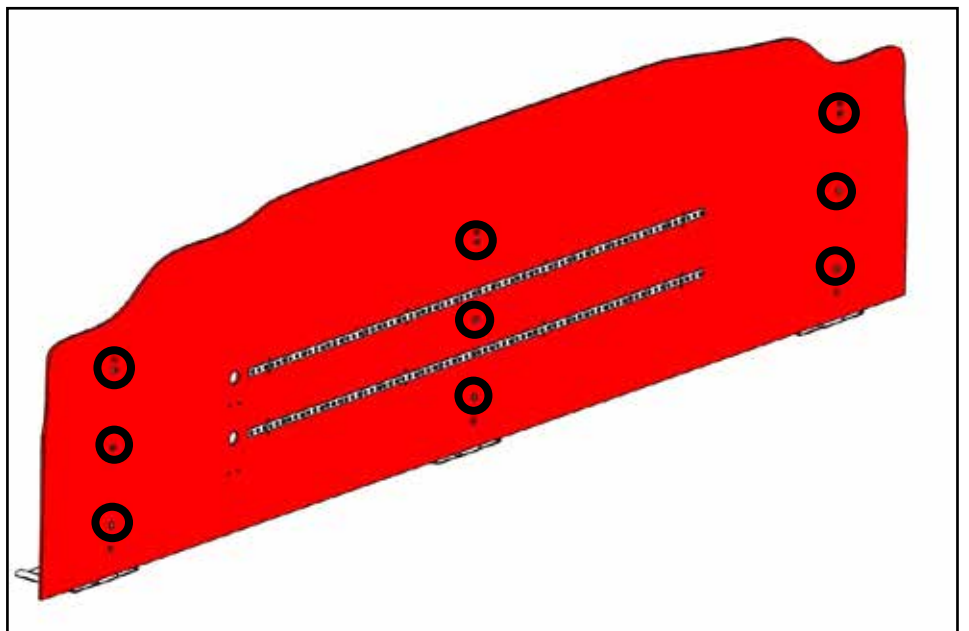
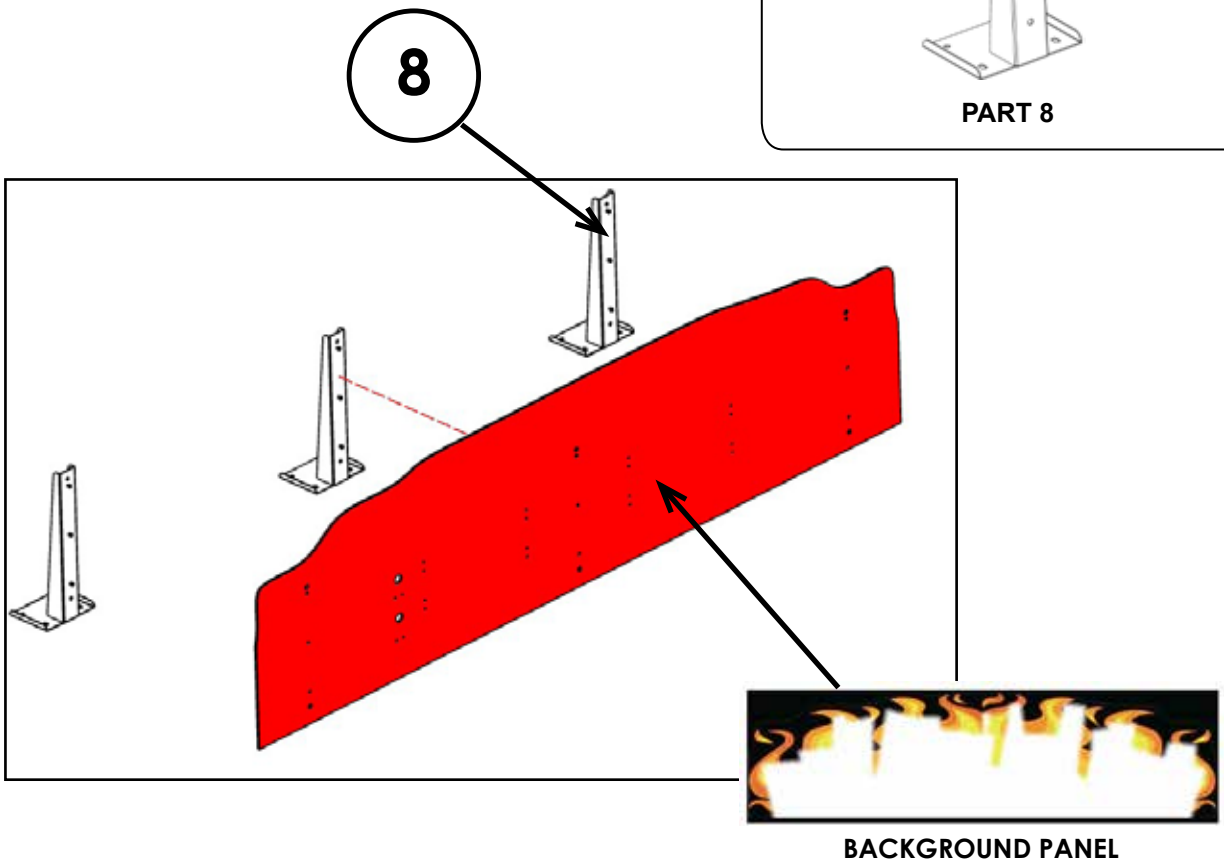
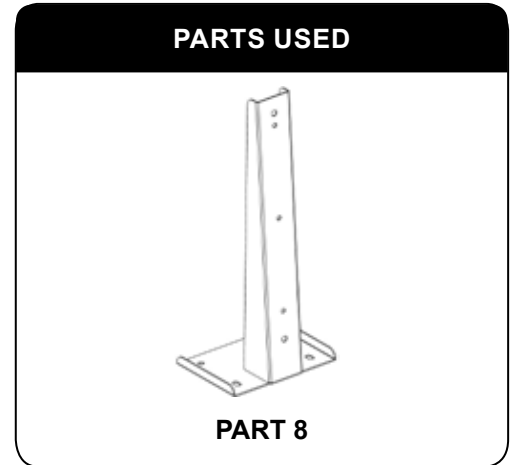

**2** Apply the **REAR PANEL** into position using the 4 x **FIXING C** and **Spacers** (2 on each Bracket)



**REAR PANEL**

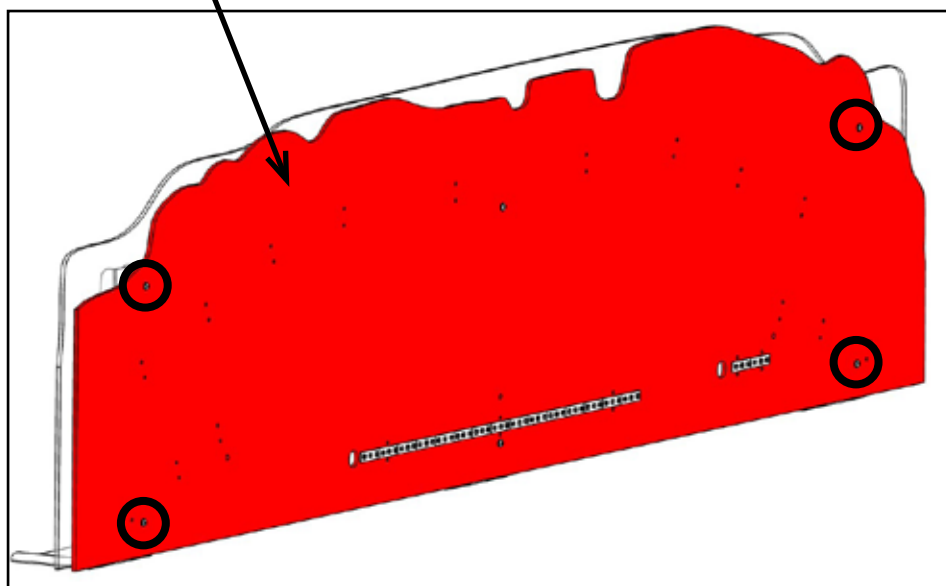

**Spacer**

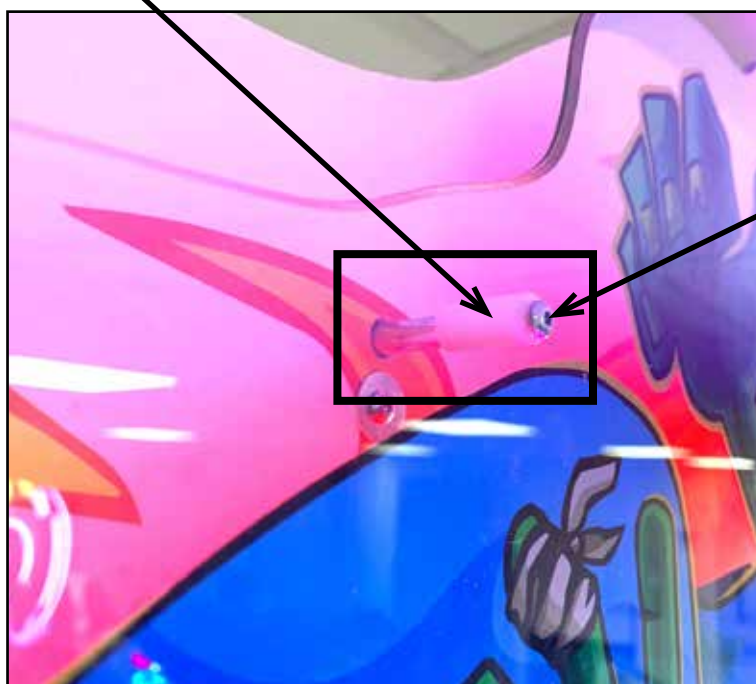

**FIXING C**

# STOP IMPORTANT!

Use at least 2 people and a suitable stepaldder when raising the Billboard into position on top of the Monitor Cabinet

- 3 Place the **BILLBOARD** into position and secure using the 4 x **FIXING A** + **WASHER A** on each **PART 8**

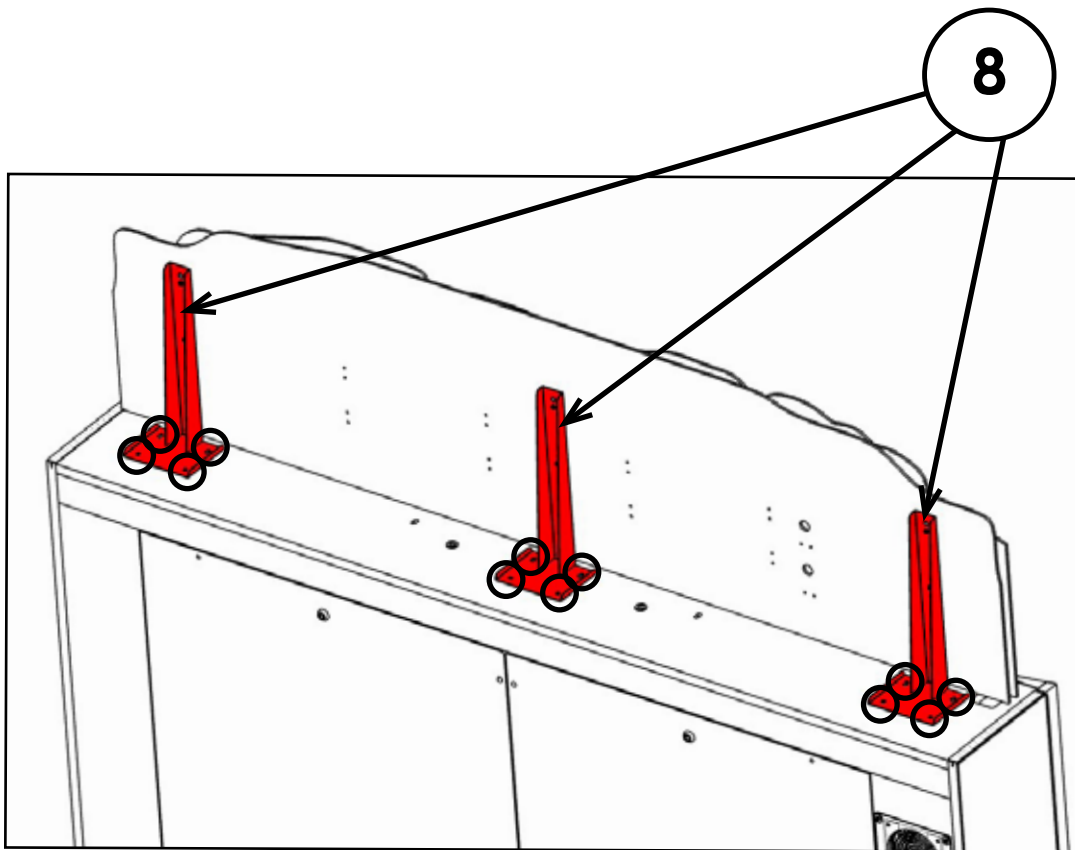

**4** Connect **Harness - ZR-60042UK (BB LED)** from the Billboard to **Harness (BB)** inside the Monitor Cab by feeding Harness through access point on the right-hand side of the Monitor Cab

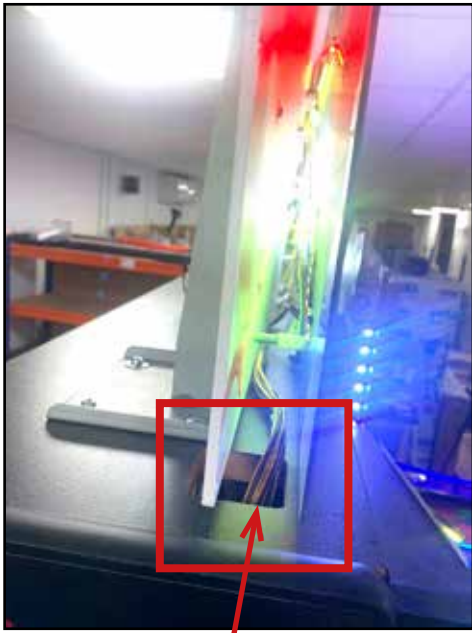

**Feed Harness**

**Connect Harness**

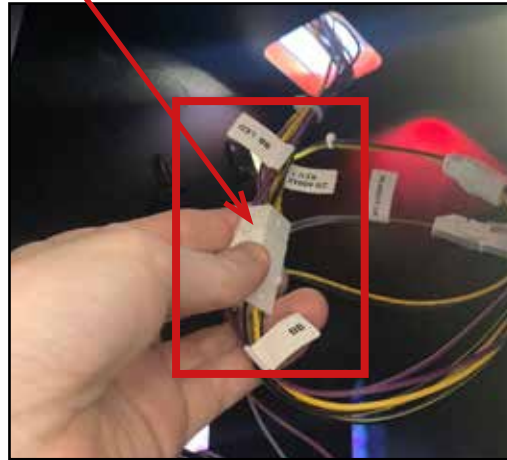

**5** Connect **Harnesses - Z1 and Z2** on the Billboard

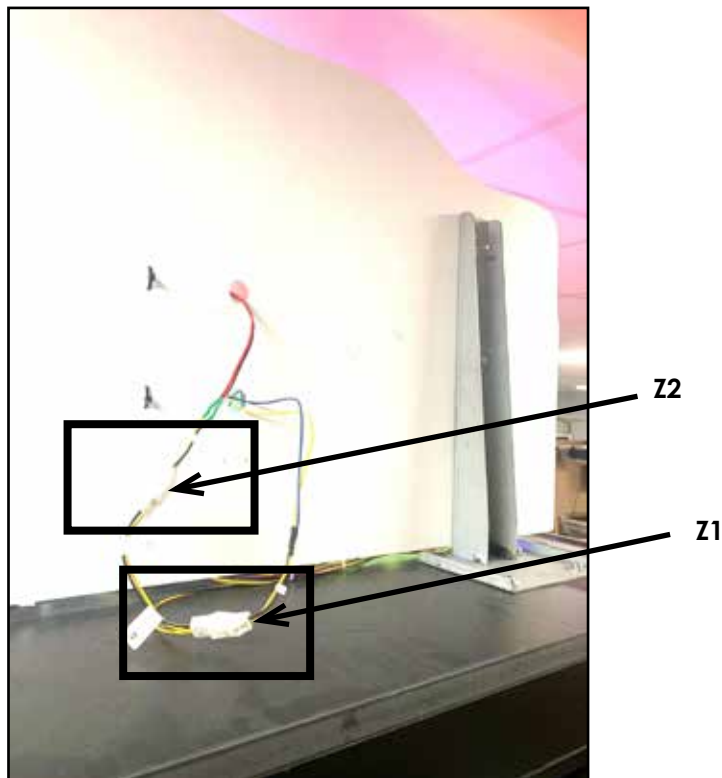

- 6 Apply the **FRONT PANEL** into position on the top of the Monitor Cab using the 3 x **FIXING B** (Fixings in Situ)



**FRONT PANEL**

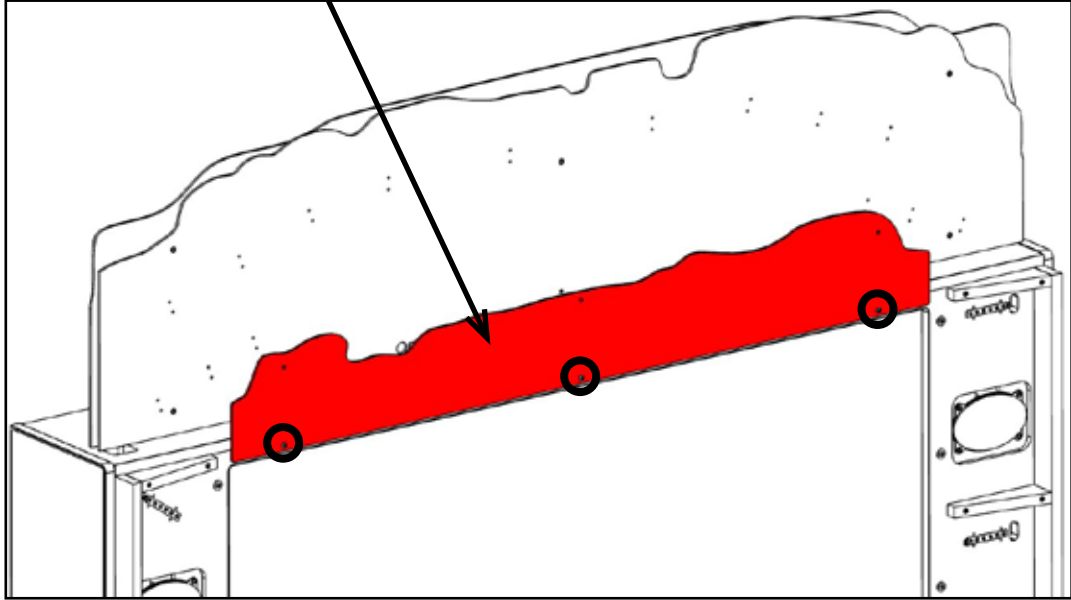

## 6-3 INSTALLING THE SUPER BONUSES

- 1 Apply **PART 9 (BLUE)** onto the rear end of each of the **PART 10 (BLUE)**. Secure using **4 x FIXING D + WASHER A**

**PART 9 (BLUE)**

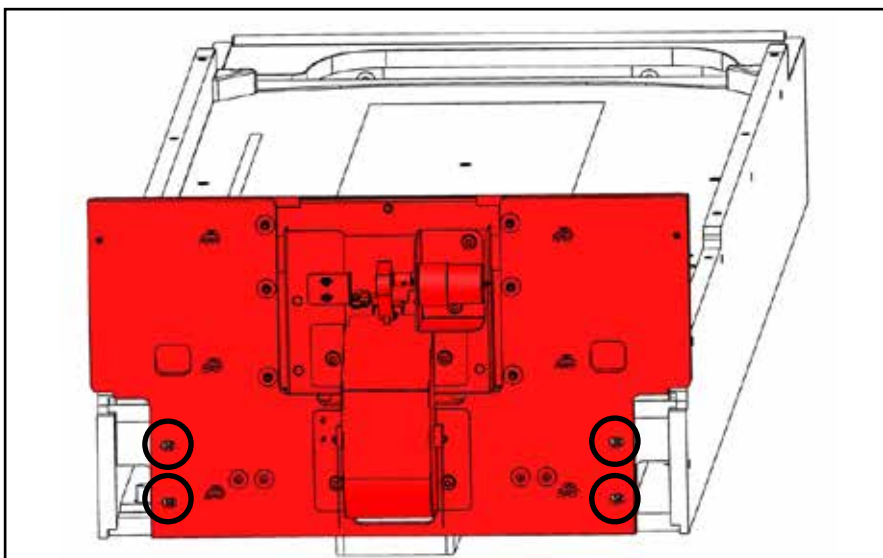
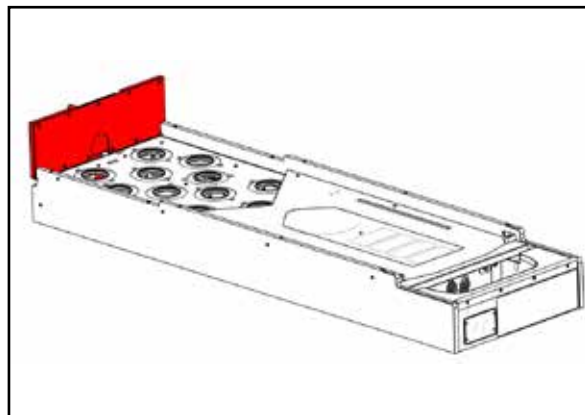
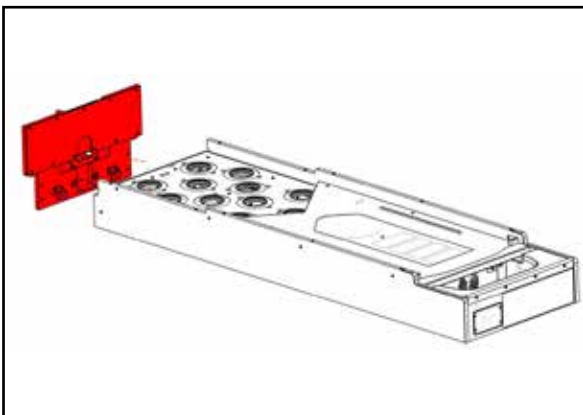

**FIXING D**



2 Attach **Harness - ZR-60028UK (SB)** from **PART 9** to **Harness - BNS** on **PART 10**

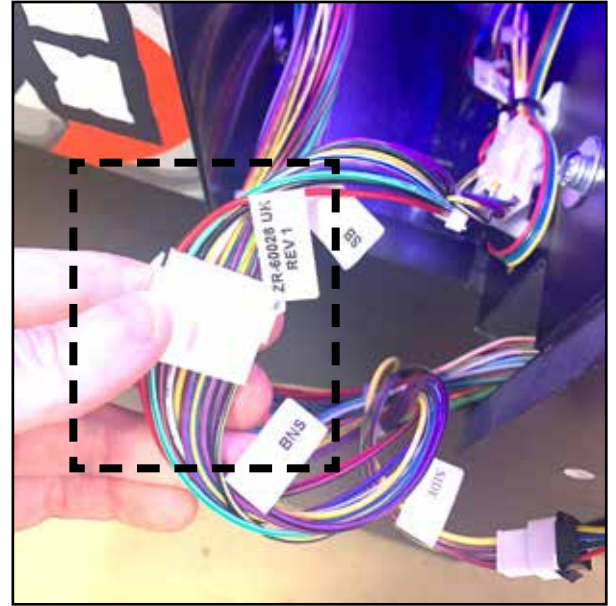
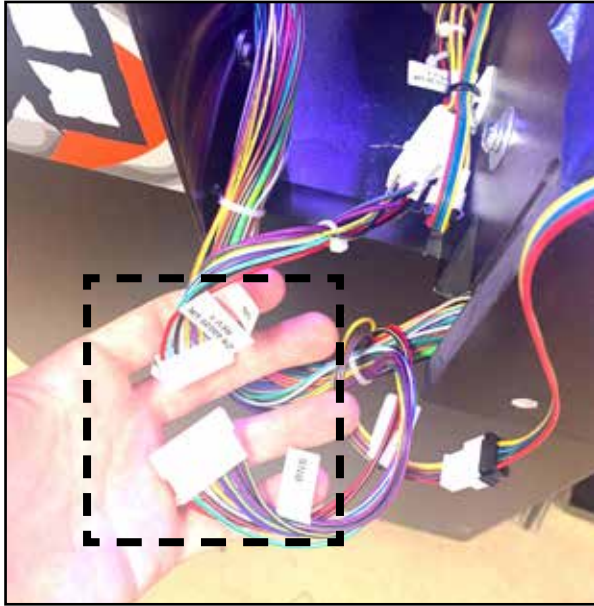

3 Repeat Steps 1 and 2 for **Players 2 (PINK), 3 (GREEN), and 4 (RED)**

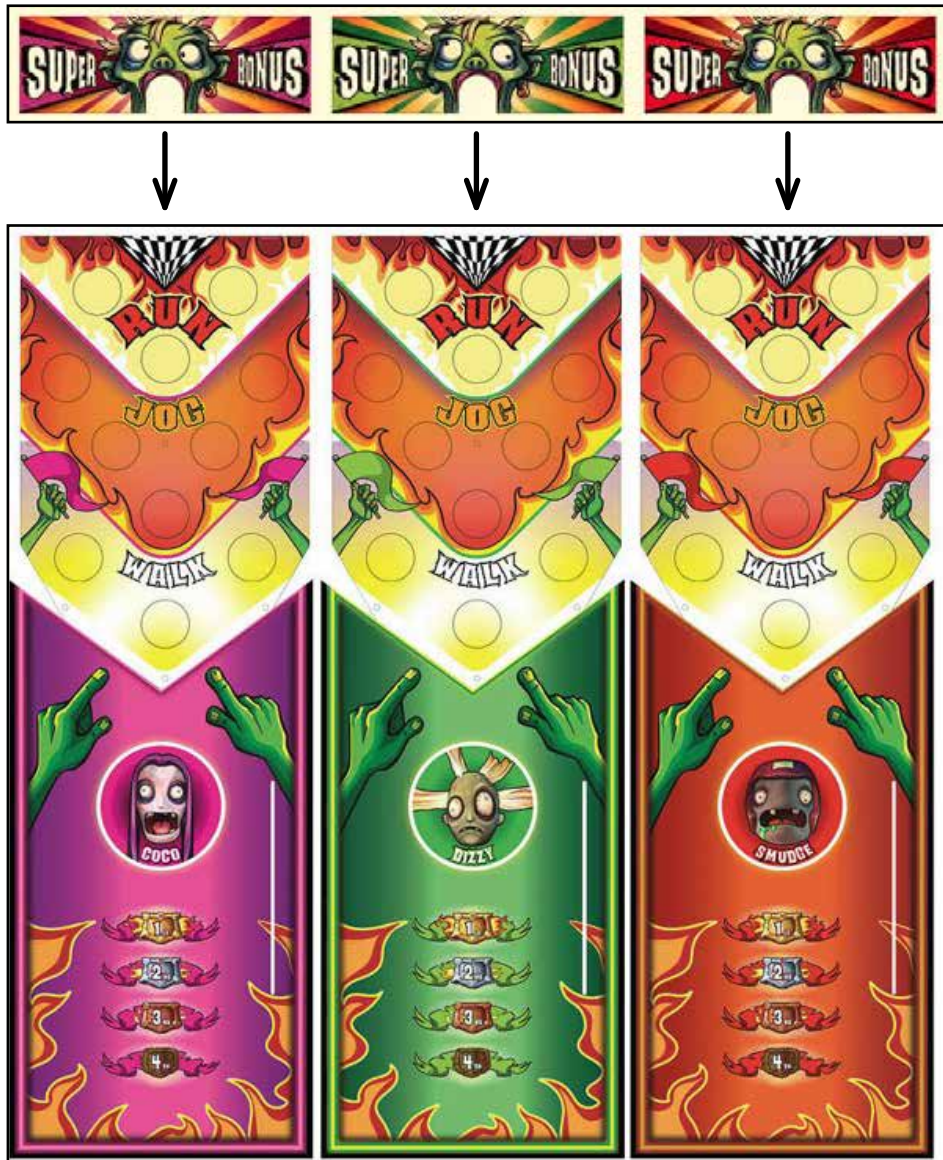

## 6-4 INSTALLING PLAYDECKS 3 AND 4 (GREEN AND RED)

- 1 Move the Control Cab for **PLAYERS 3 and 4 (GREEN and RED)** into position in front of the Monitor Cab

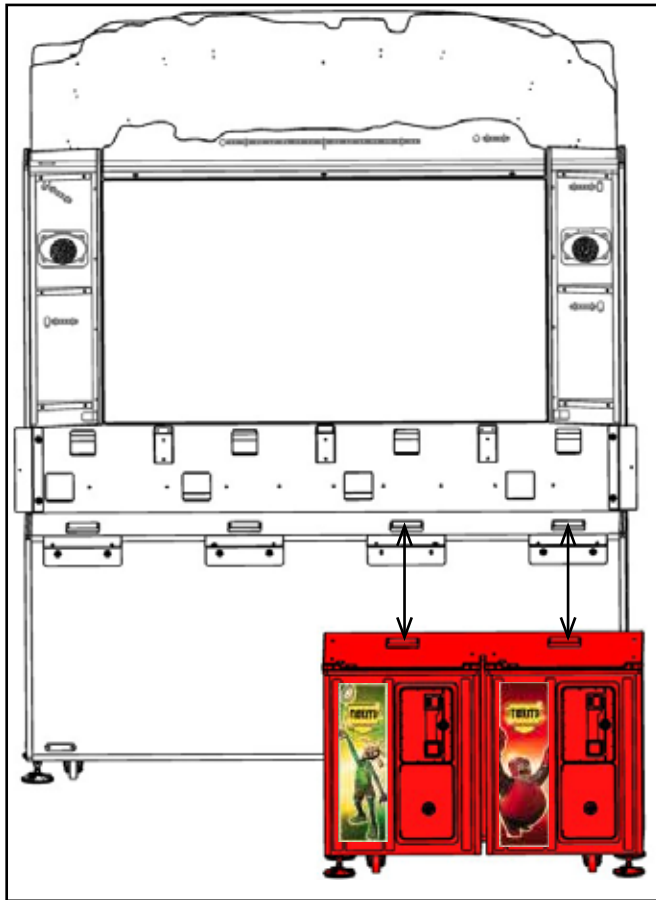



2 Insert **PLAYER 4 (RED) PLAYDECK** into position by aligning the **Locating Blocks** on the underside of the Playdeck with the **Locating Holes**

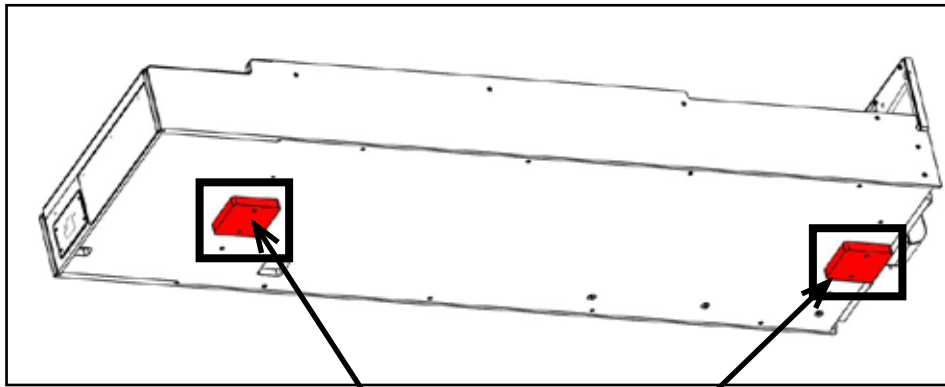

Locating Blocks

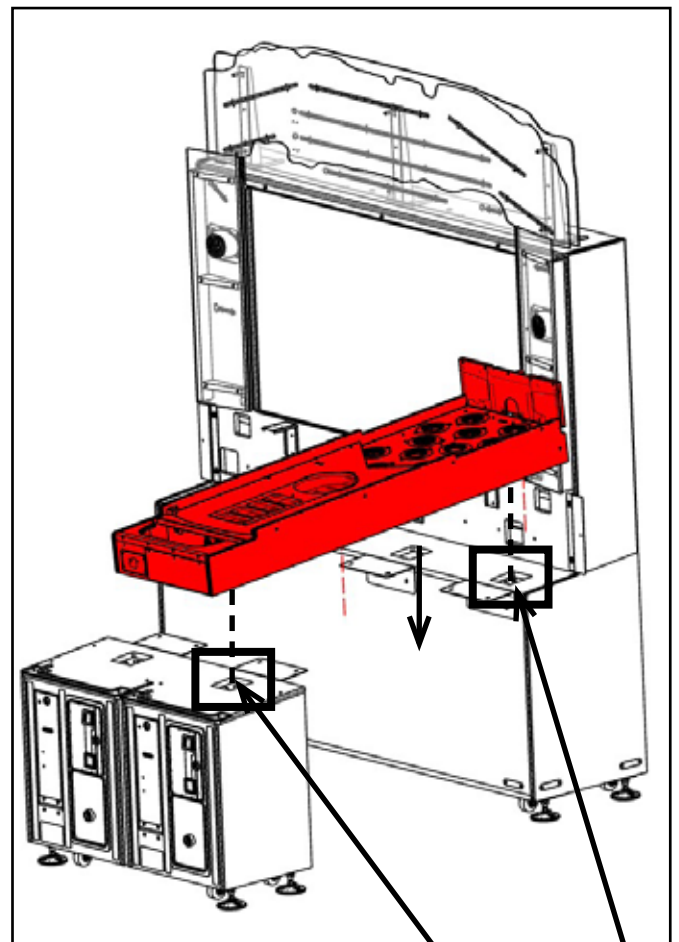

Locating Holes

**3** Secure the Playdeck to **PART 2 + 3** using 2 x **FIXING G + WASHER E** on each Bracket

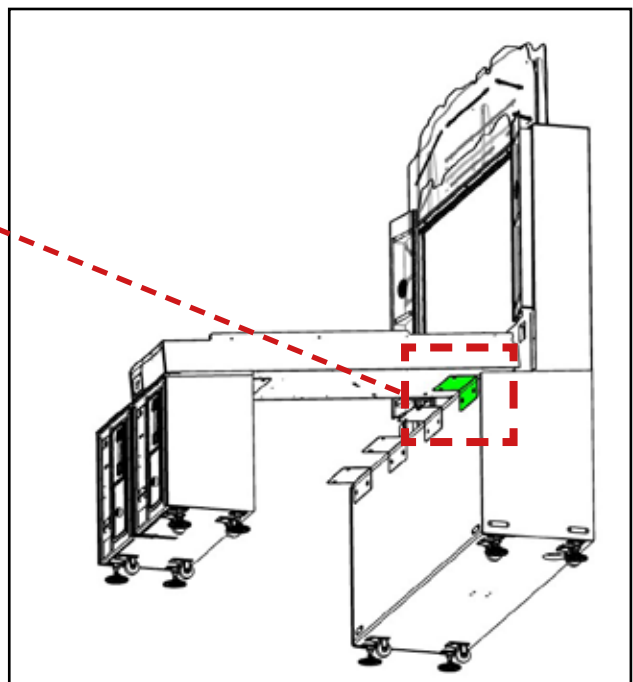
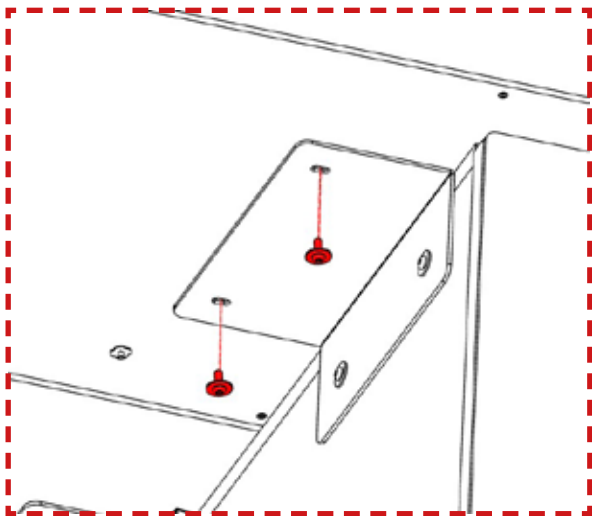
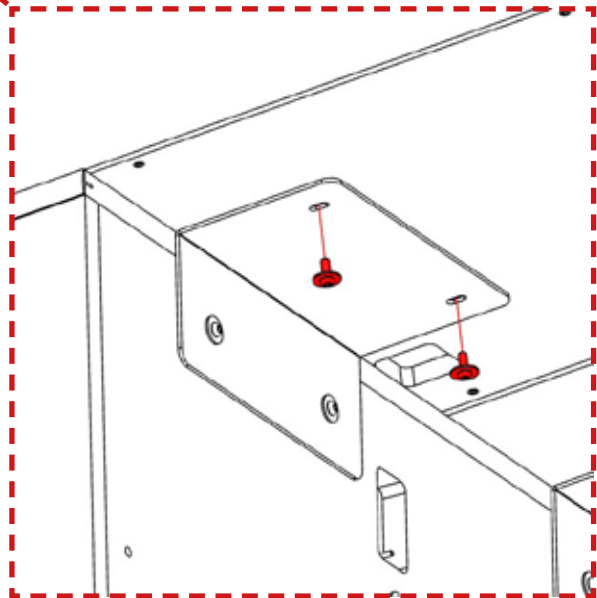
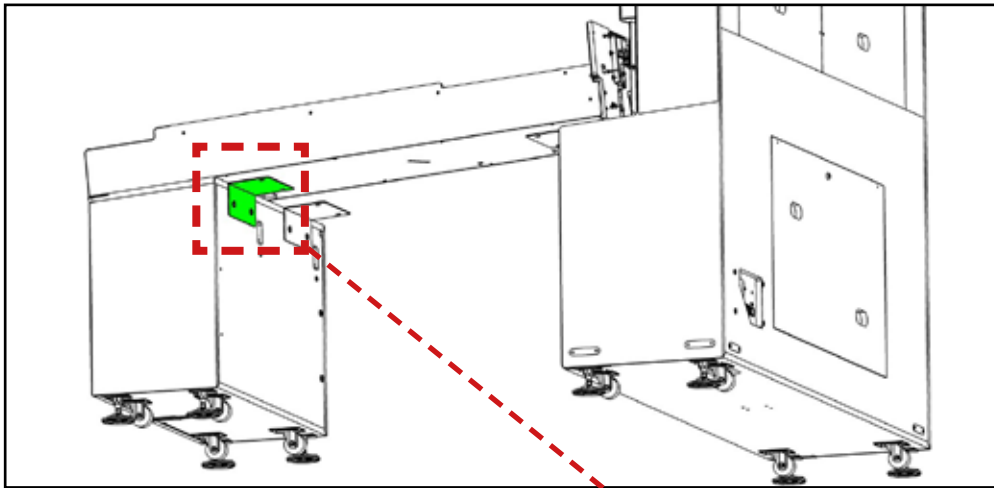

4 Feed Harnesses from Playdeck through access holes in Monitor Cab. Connect **Harnesses (ZR-60029UK, P4 SL, PWR, P4 A, P4 PNL, SEN, ZR-60016UK/OUT)** from **Player 4 (RED)** to the Monitor Cab

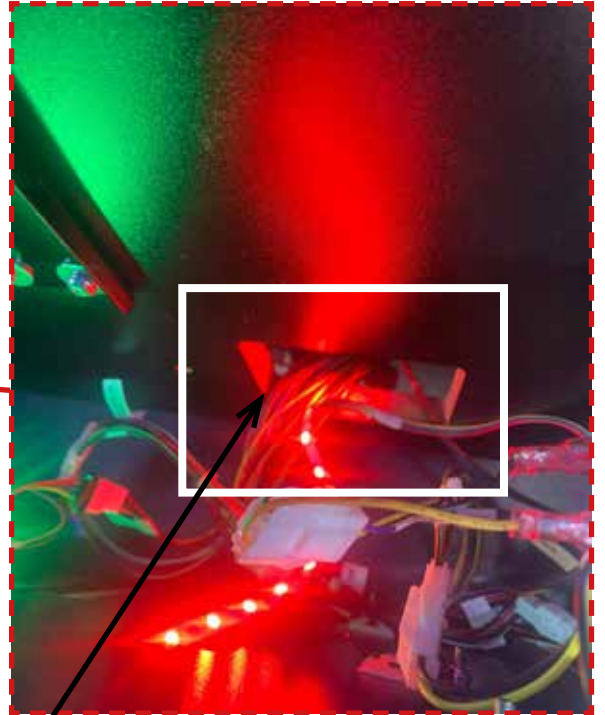
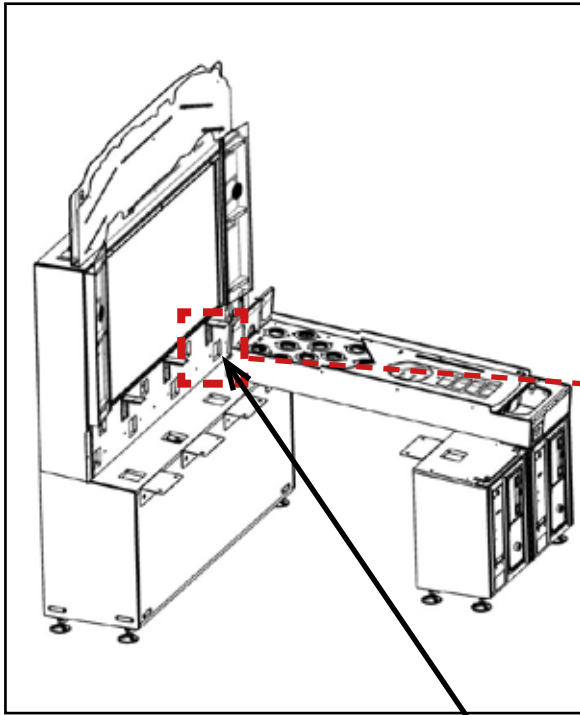

Feed Playdeck  
Harnesses through  
Here

Connect from  
Playdeck to  
Monitor Cab



**5** Connect **Harness (CTRL)** and **apply Earth to Wire Ring Terminal** on Control Cab for **Player 4 (RED)**.  
Apply **PART 11** into position. Secure using **1 x FIXING E + WASHER B**

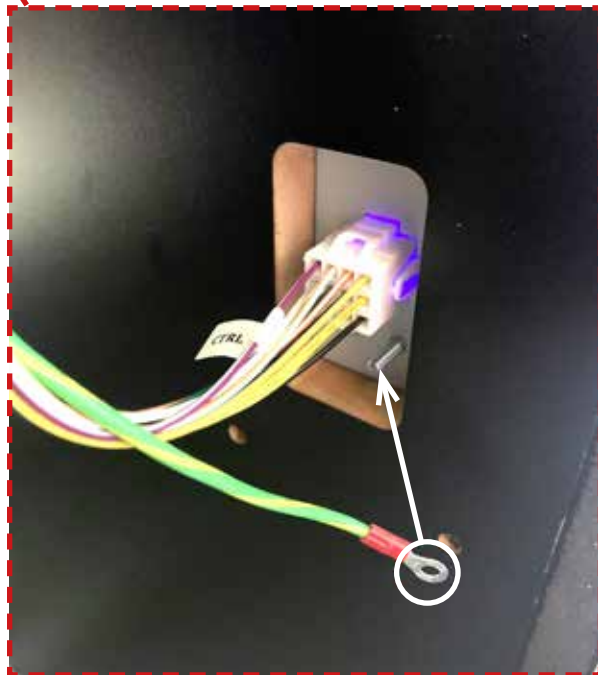
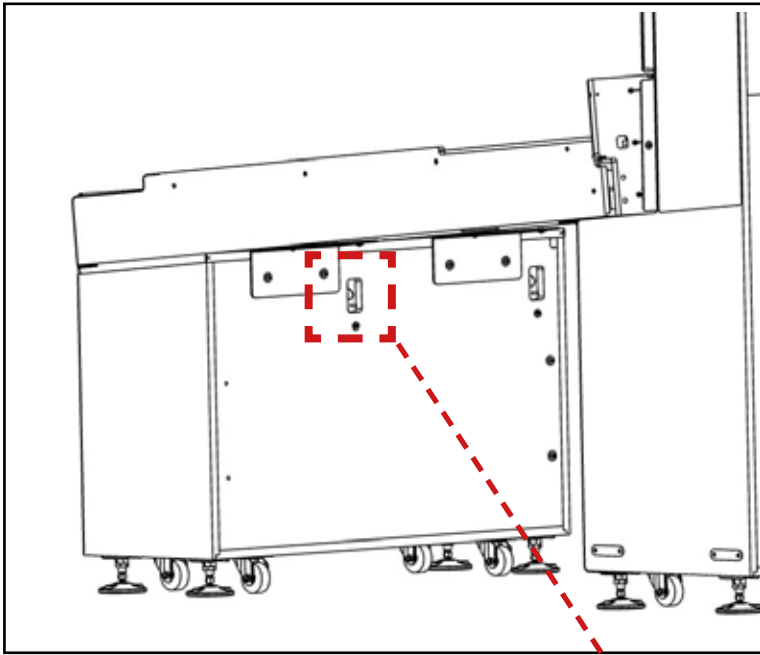

**9 ASSEMBLY AND INSTALLATION**

**PARTS USED**



**PART 11**

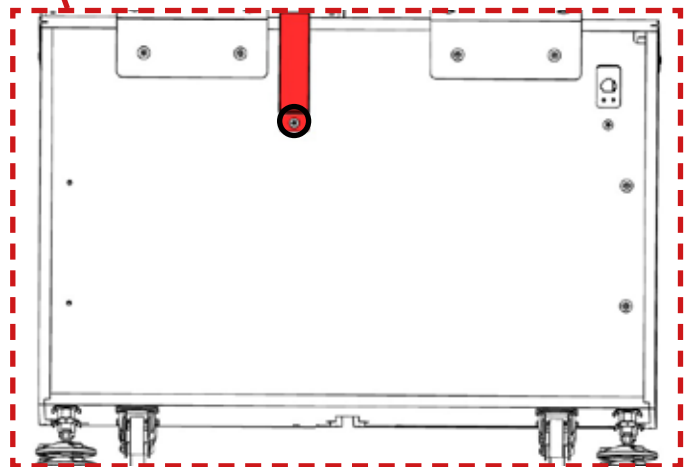
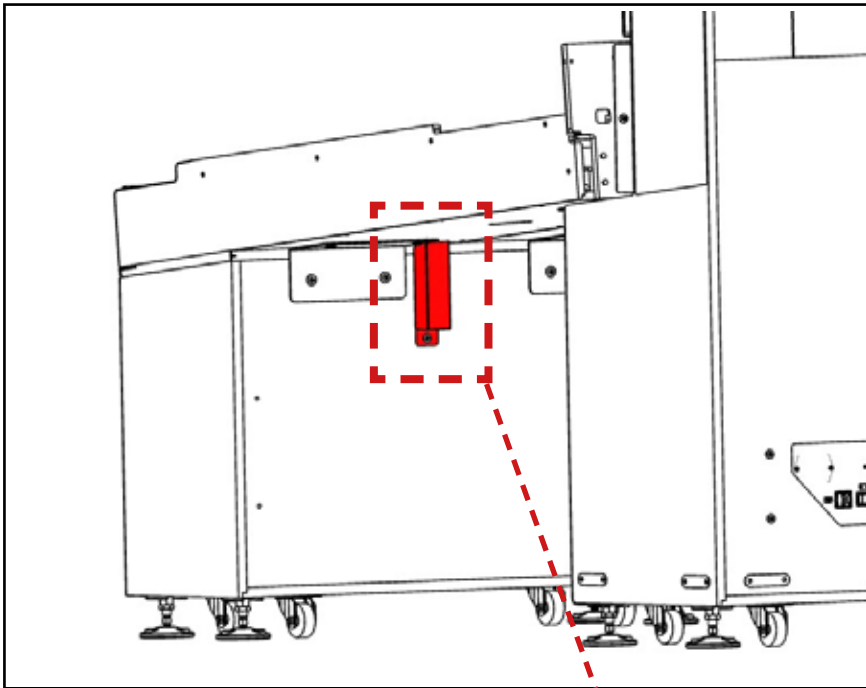

**6** Insert **PLAYER 3 (GREEN) PLAYDECK** into position (repeat **Steps 2 and 3** for alignment and securing)

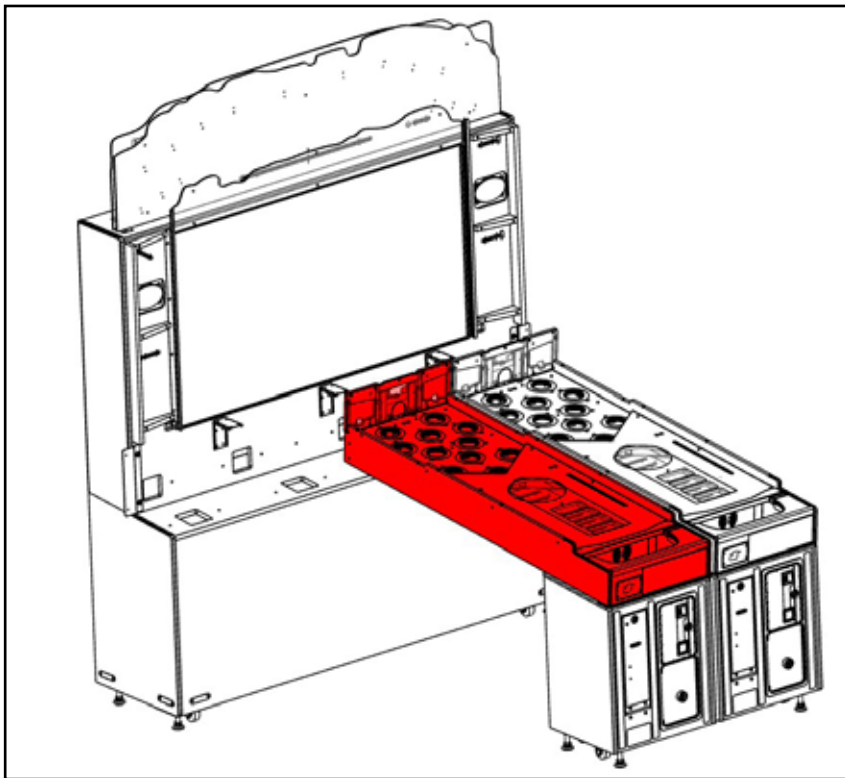

**7** Repeat **Steps 4 and 5** for **PLAYER 3** (Cabinet Harnesses (**ZR-60016UK/OUT, P3 PNL, SEN, PWR, P3 A, IN**), Control Cab Harness (**CTRL**) and Cover (**PART 11**))

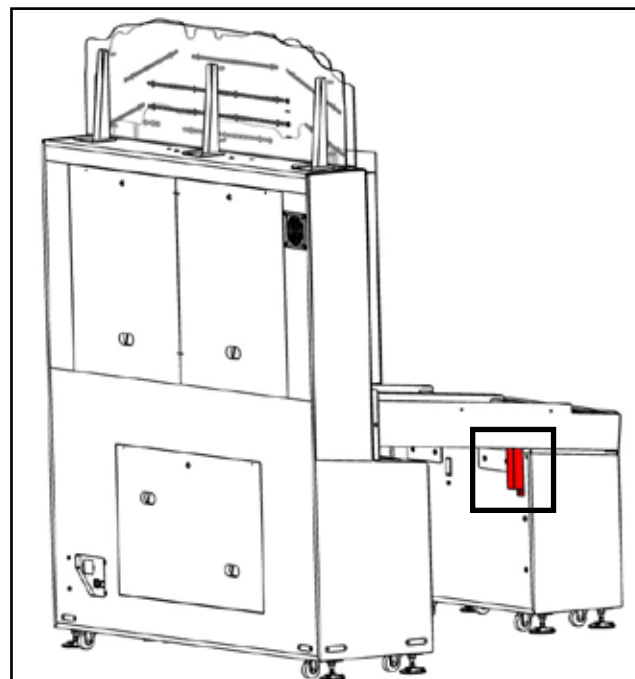
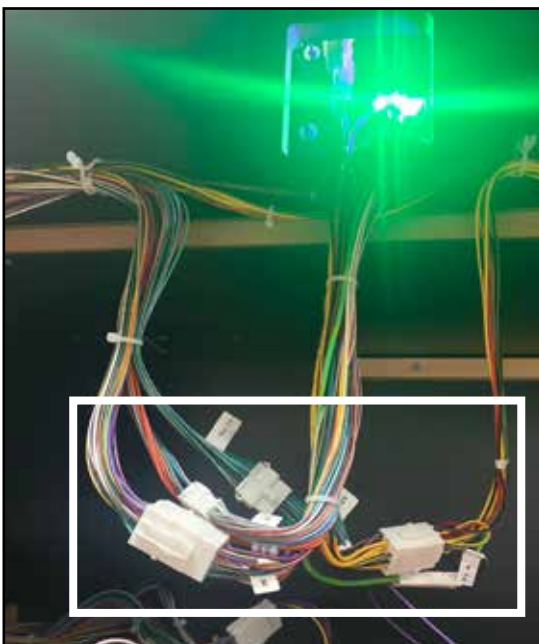



8

Insert 1 x PART 12 between Player 3 and 4. Secure using the 10 x FIXING B highlighted (5 fixings on each side). Attach Harness (SIDE) from PART 12 to Monitor Cab

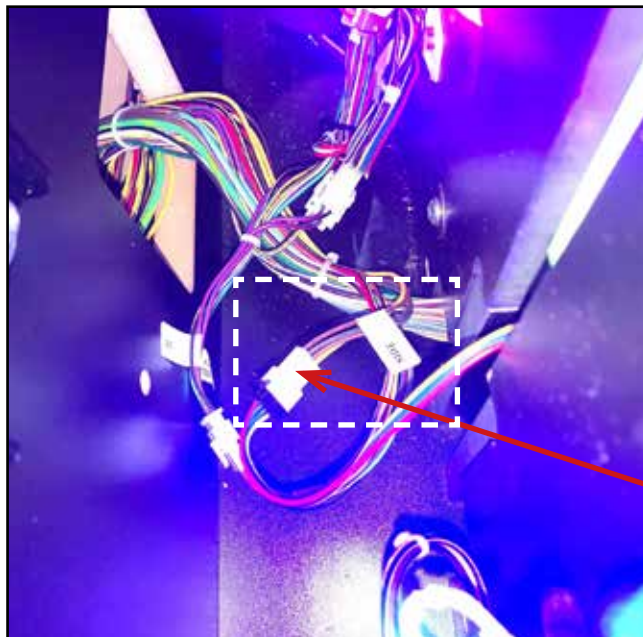
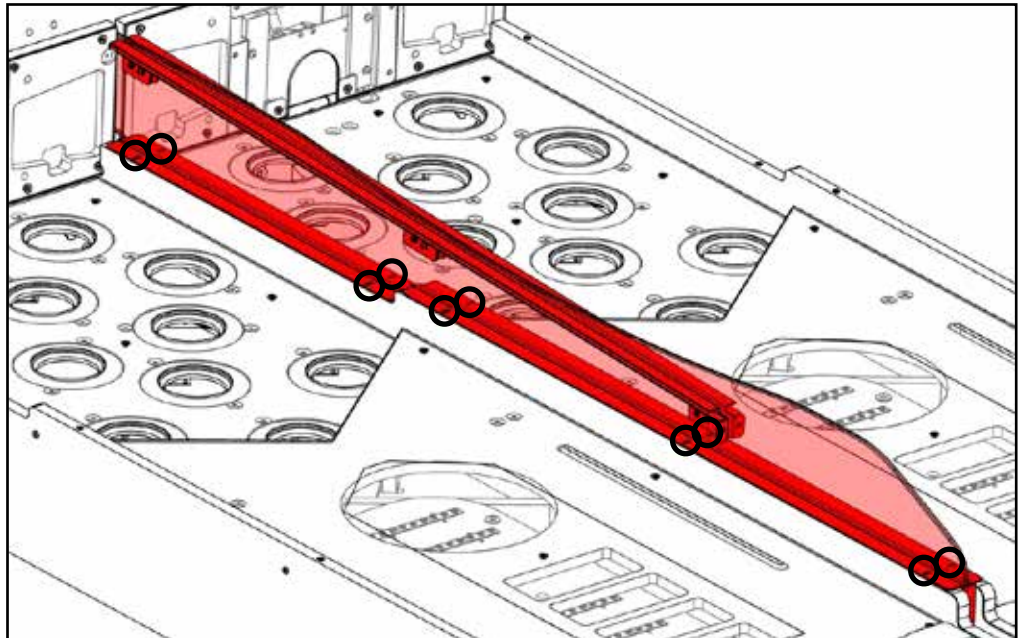
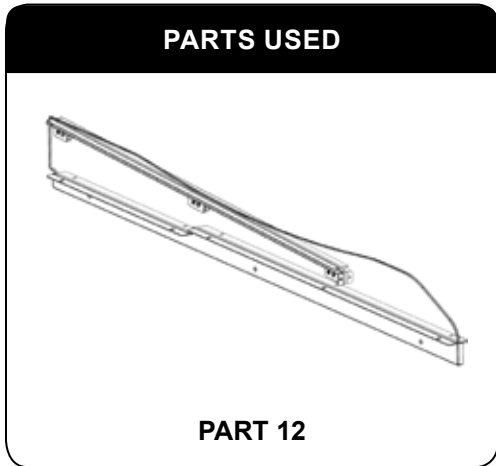

Harness (SIDE)

## 6-5 INSTALLING PLAYDECKS 1 AND 2 (BLUE AND PINK)

- 1 Place the Control Cab for **PLAYERS 1 and 2 (BLUE and PINK)** into position in front of the Monitor Cab

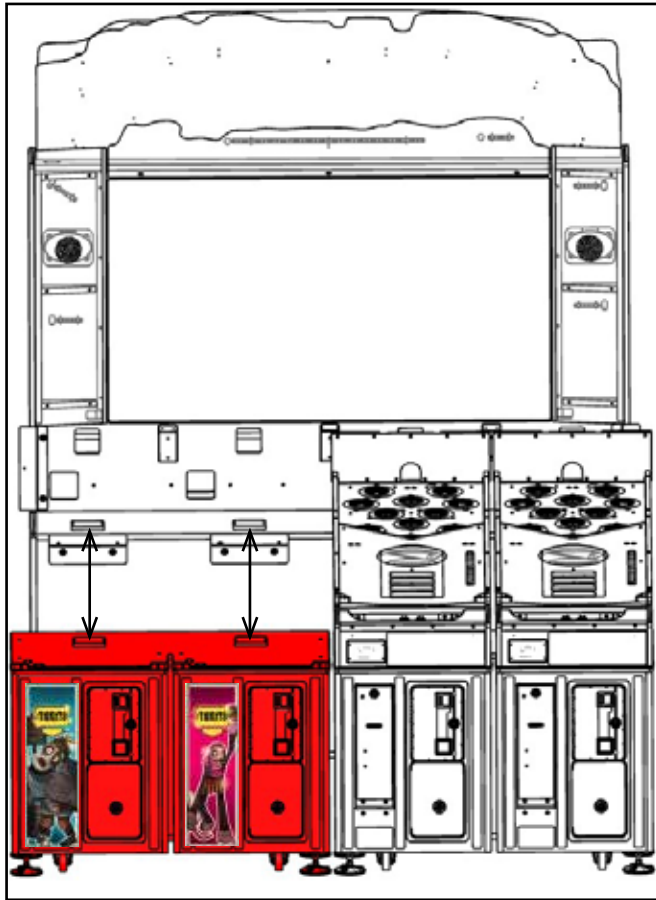

- 2 Apply **PART 13** into position. Secure using 4 x **FIXING A + WASHER A + E**

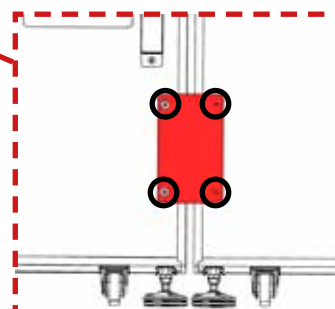
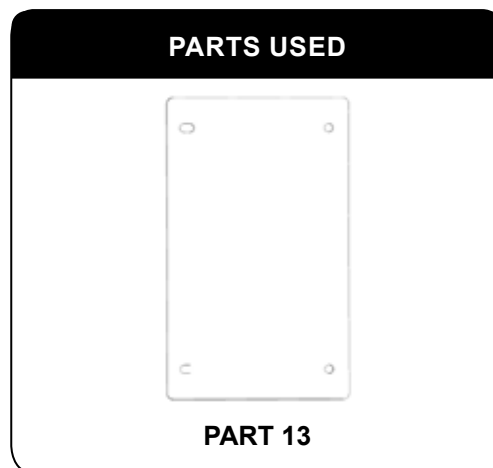
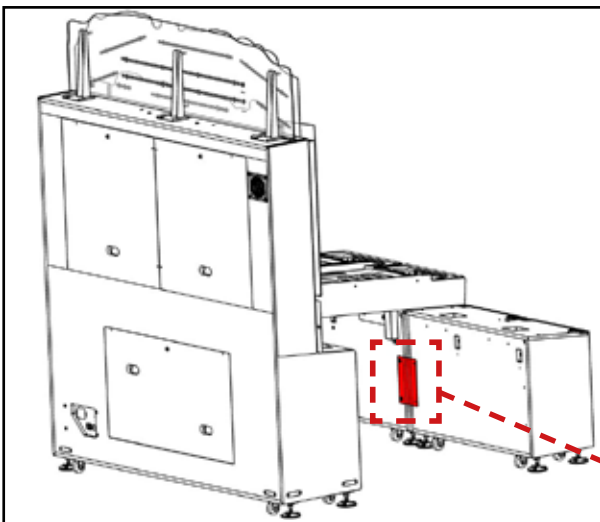



3 Rotate and apply 2 x PART 3 to the Control Cab and secure using 2 x FIXING F + WASHER E

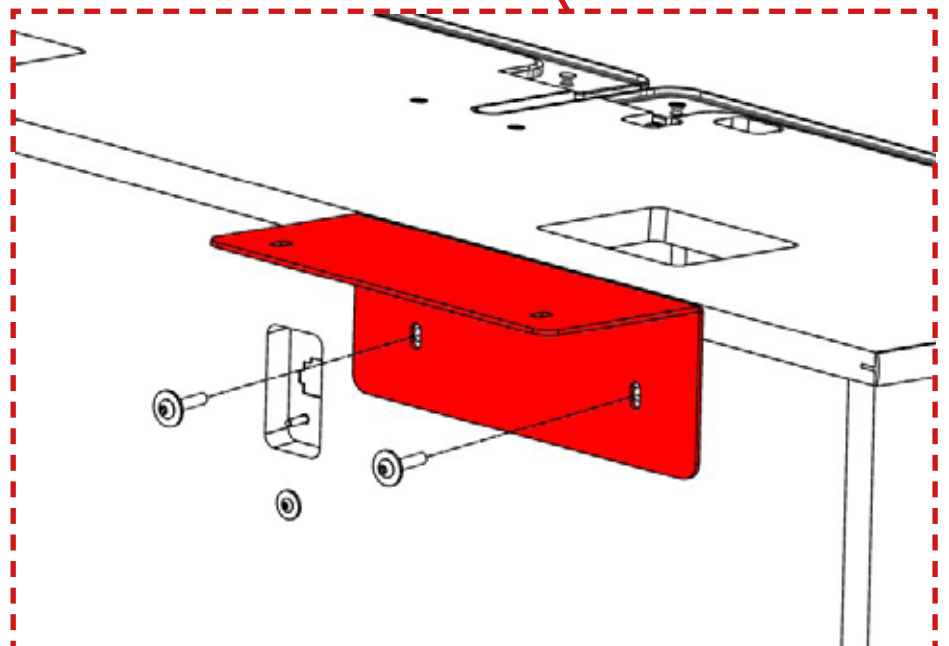
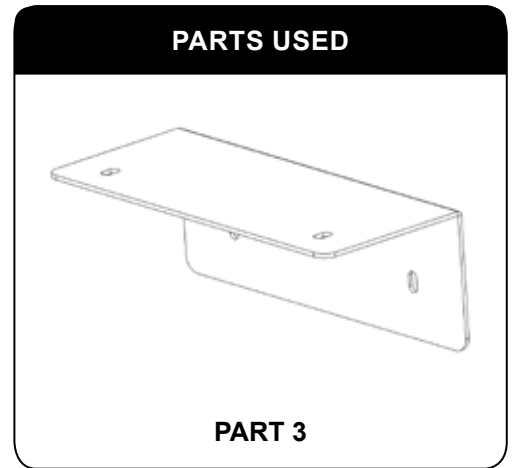
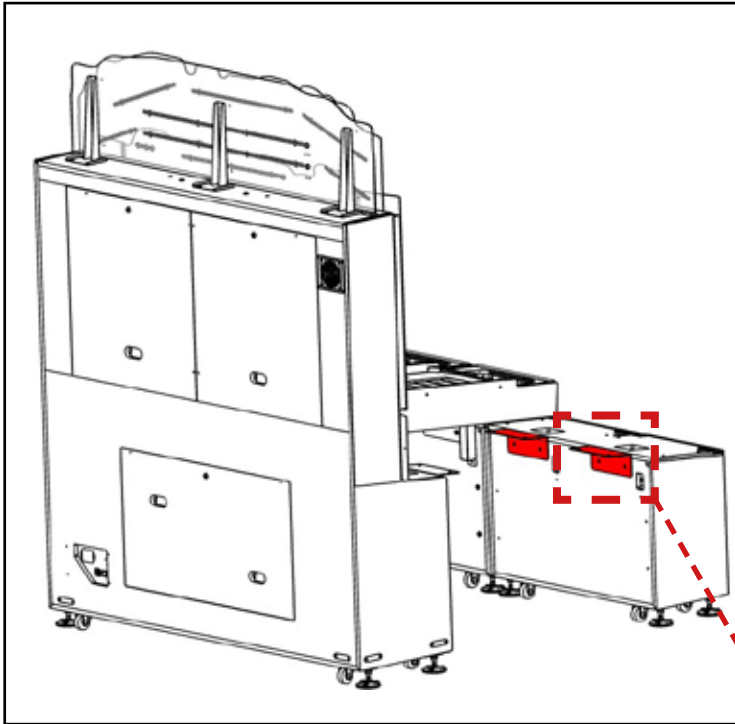

- 4** Insert **PLAYER 2 (PINK) PLAYDECK** into position by aligning the **Locating Blocks** on the underside of the Playdeck with the **Locating Holes**

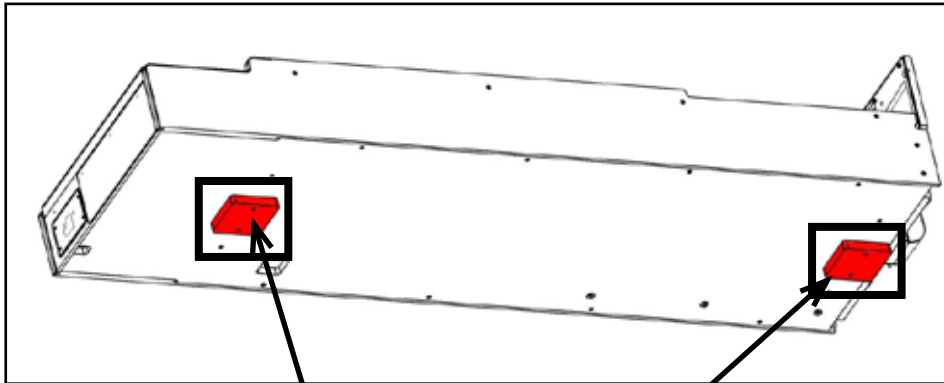

Locating Blocks

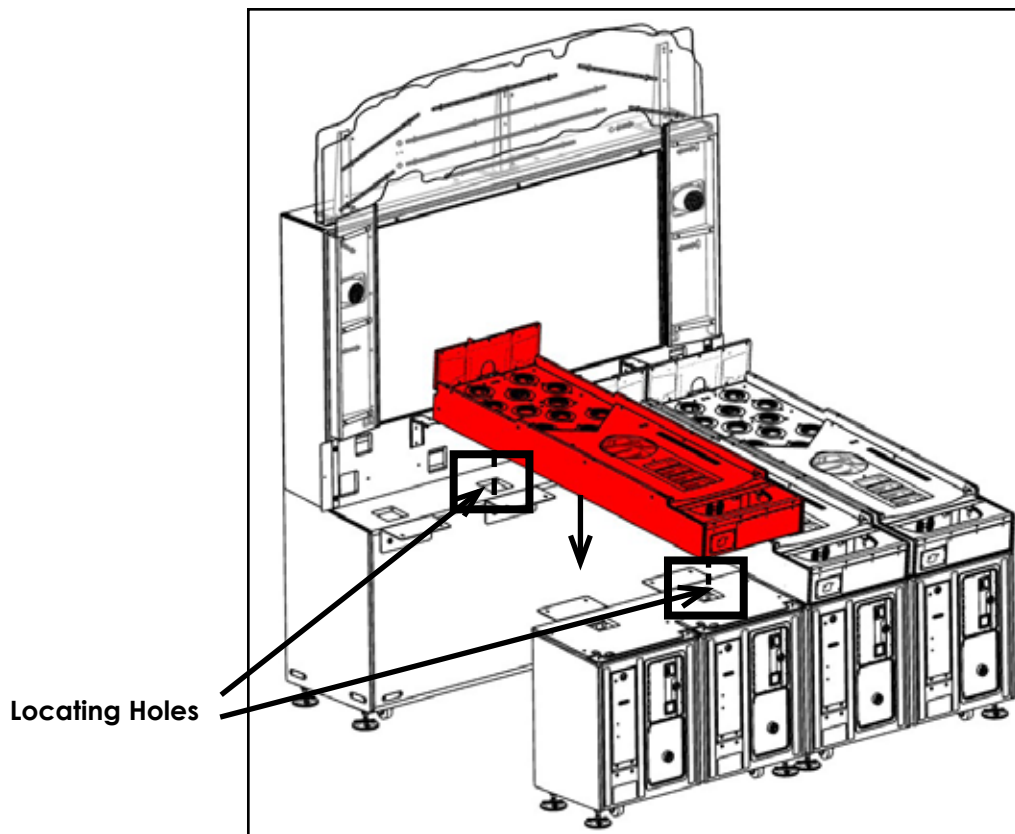

Locating Holes

5 Secure the Playdeck to PART 2 + 3 using 2 x FIXING G + WASHER E on each Bracket

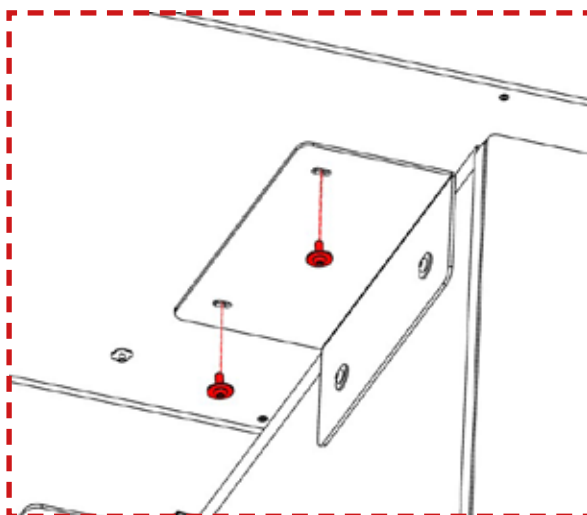
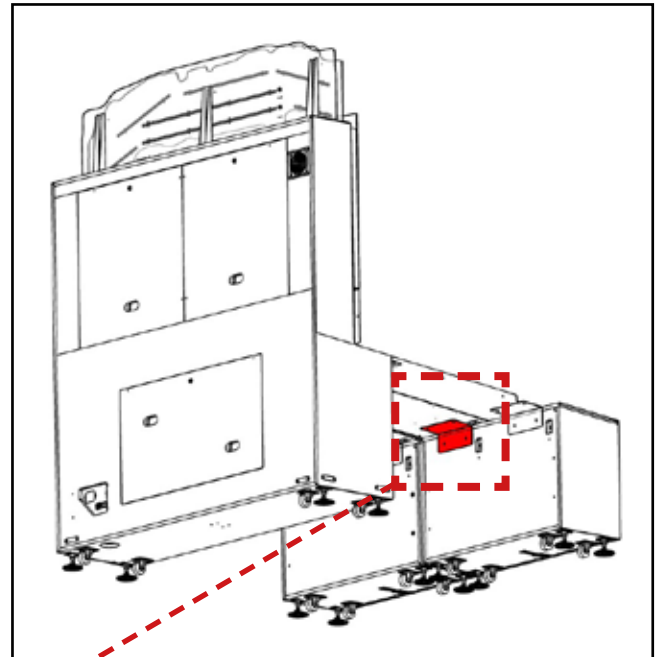
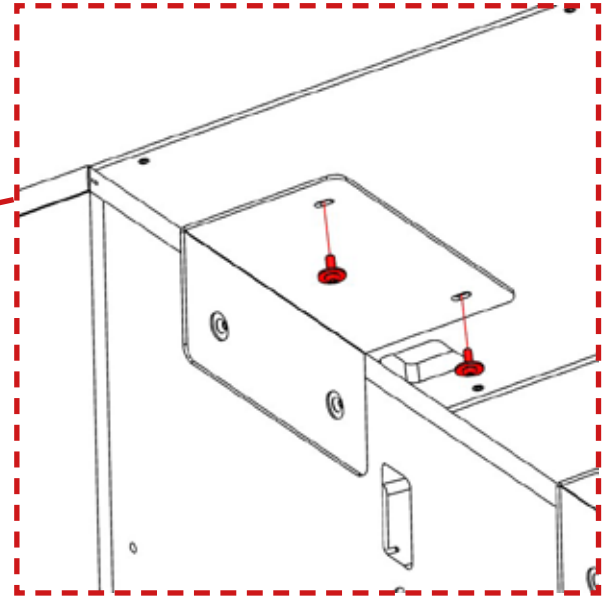
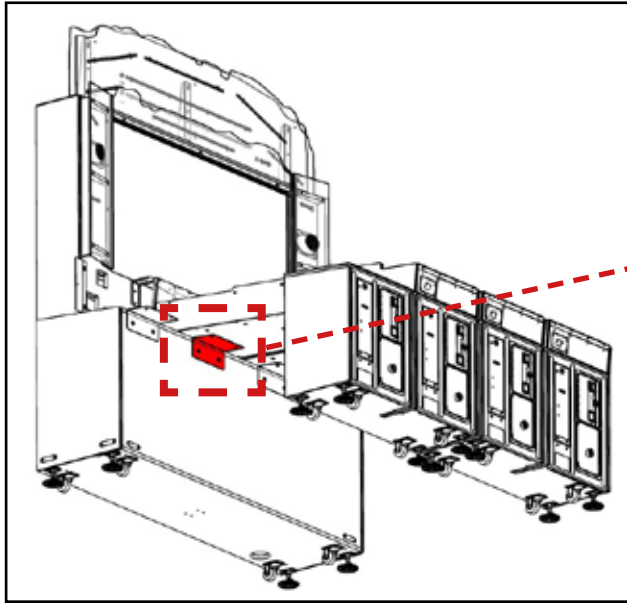

**6** Feed Harnesses from Playdeck through access holes in Monitor Cab. Connect **Harnesses (ZR-60016UK/OUT, P2 PNL, SEN, PWR, P2 A, IN)** from **Player 2 (PINK)** to the Monitor Cab

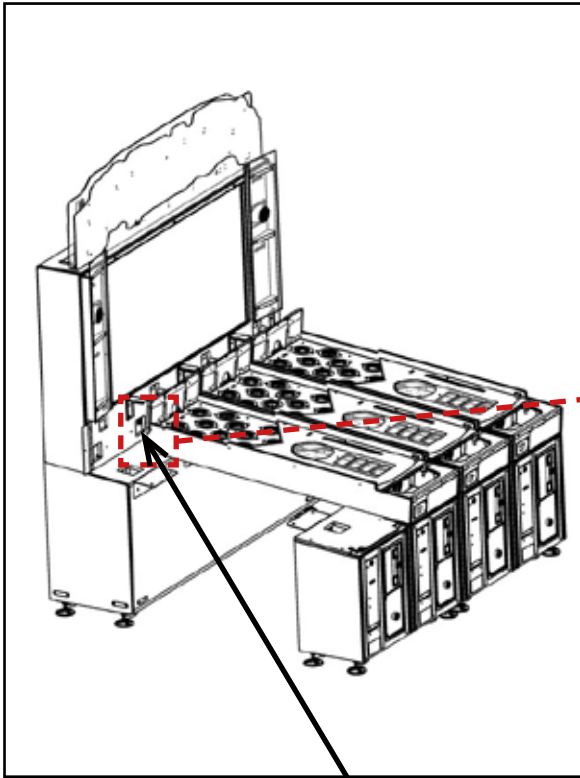

Feed Playdeck  
Harnesses through  
Here

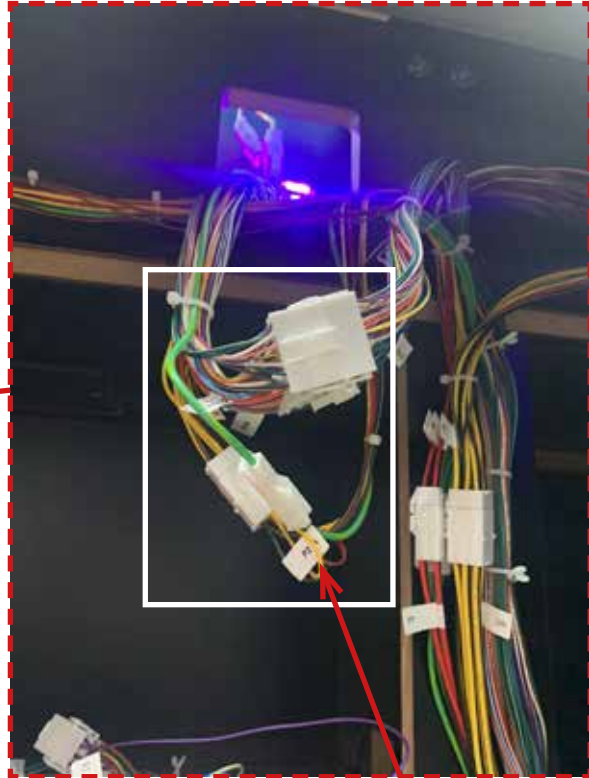

Connect from  
Playdeck to  
Monitor Cab

**7** Connect **Harness (CTRL)** and apply Earth to **Wire Ring Terminal** on Control Cab for **Player 2 (PINK)**. Apply **PART 11** into position. Secure using **1 x FIXING E + WASHER B**

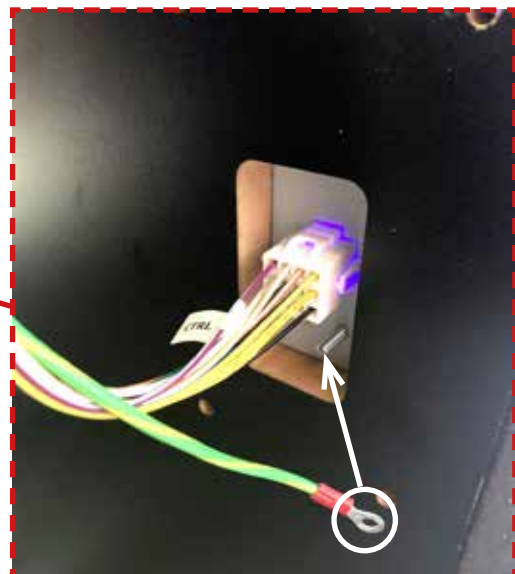
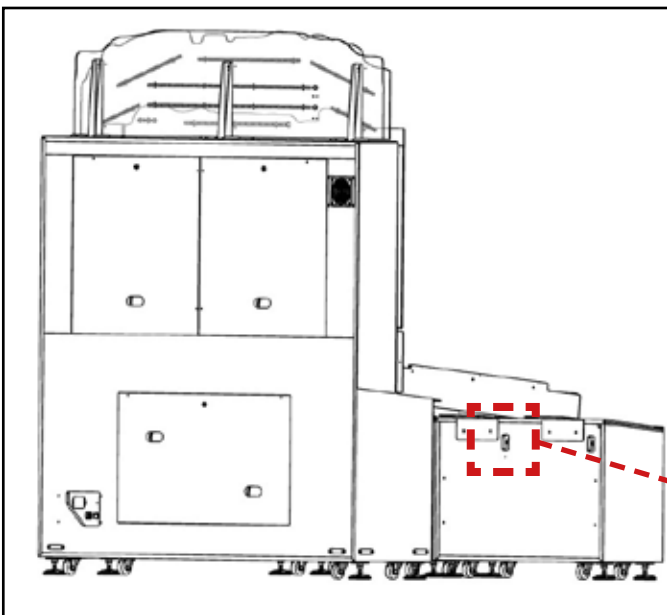

**9** ASSEMBLY AND INSTALLATION

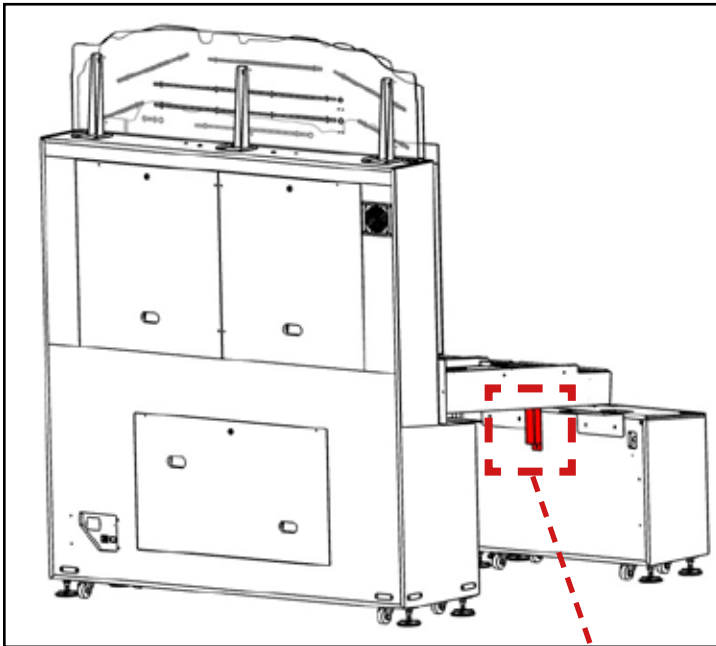

**PARTS USED**

**PART 11**

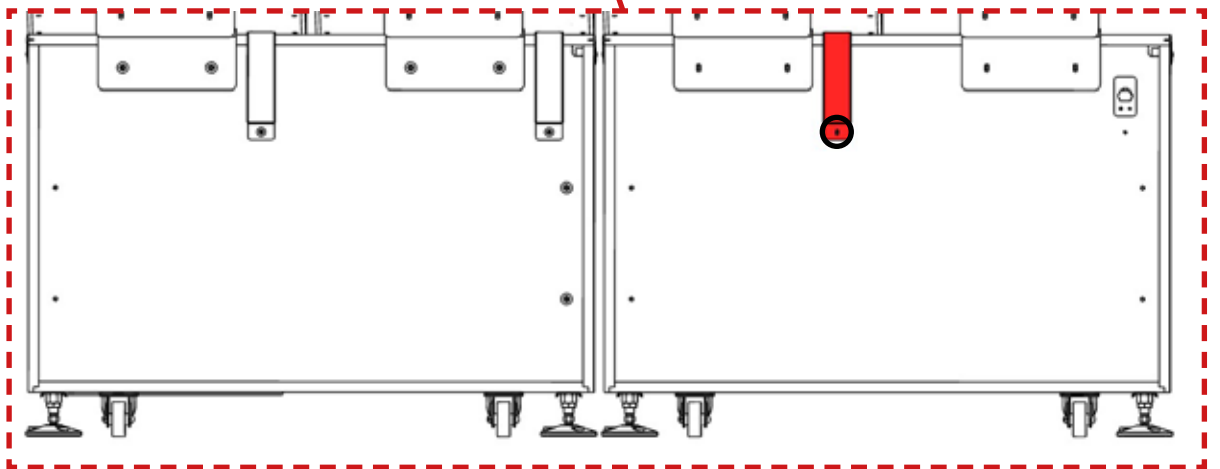
A diagram showing a single vertical rectangular component, labeled as Part 11. The component has a slightly wider top section and a narrower bottom section. It is shown in a perspective view.



- 8** Insert 1 x **PART 12** between **Player 2 and 3**. Secure using the 10 x **FIXING B** highlighted (5 fixings on each side). Attach **Harness (SIDE)** from **PART 12** to **Monitor Cab**

**PARTS USED**

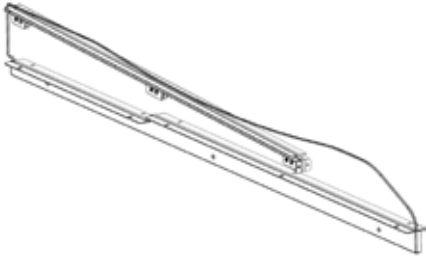

**PART 12**

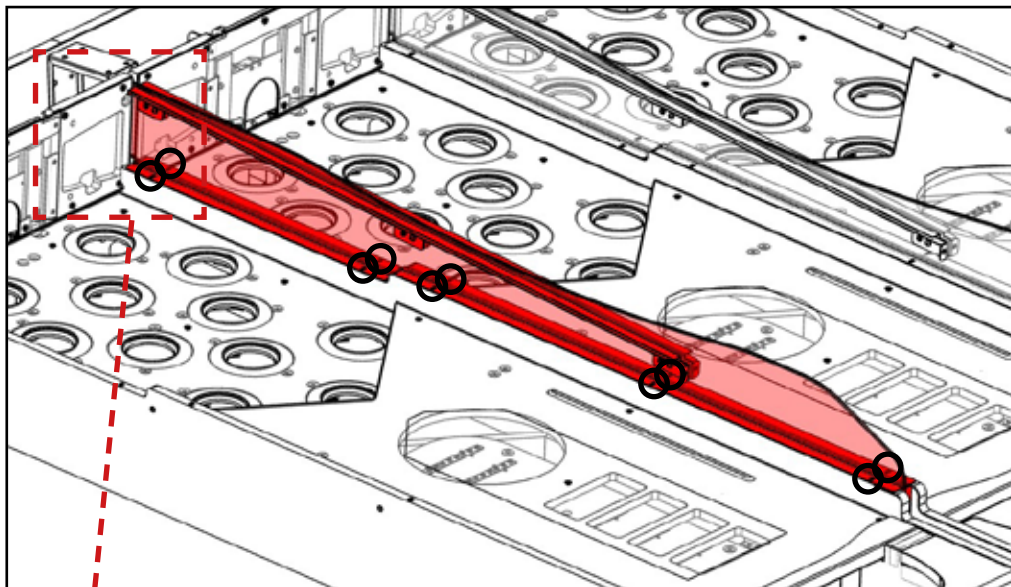

**Harness (SIDE)**

9 Insert **PLAYER 1 (BLUE) PLAYDECK** into position (repeat **Steps 4 and 5** for alignment and securing)

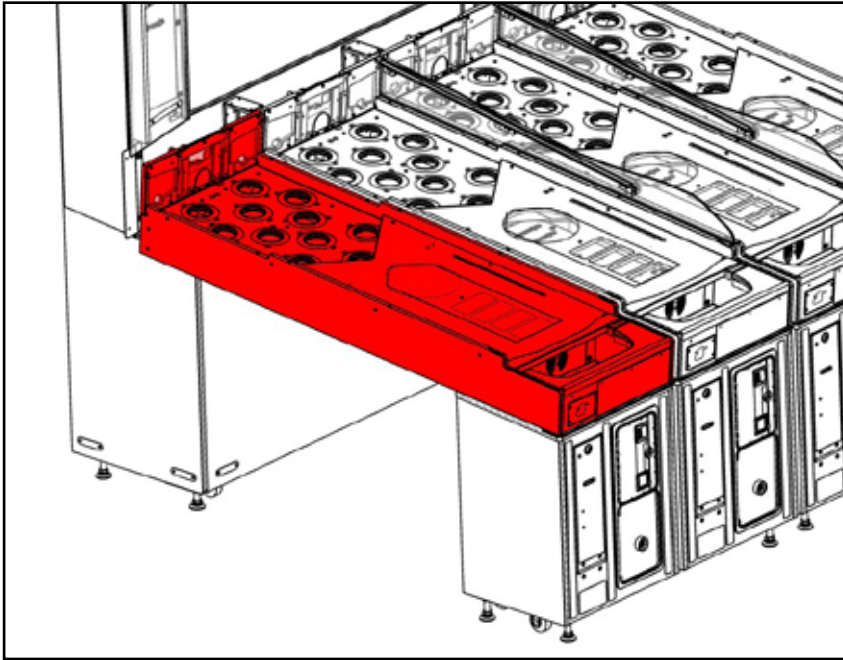

10 Repeat **Steps 6 and 7** for **PLAYER 1** (Cabinet Harnesses (ZR-60016UK/OUT, P1 PNL, SEN, PWR, P1 A, IN), Control Cab Harness (CTRL) and Cover (PART 11)

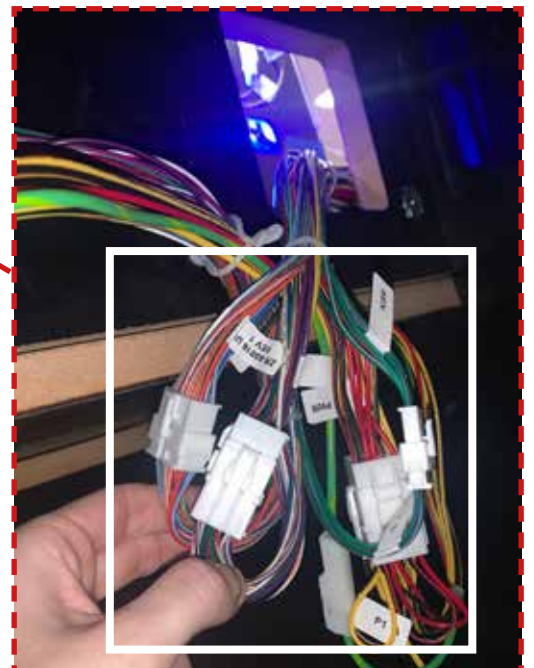
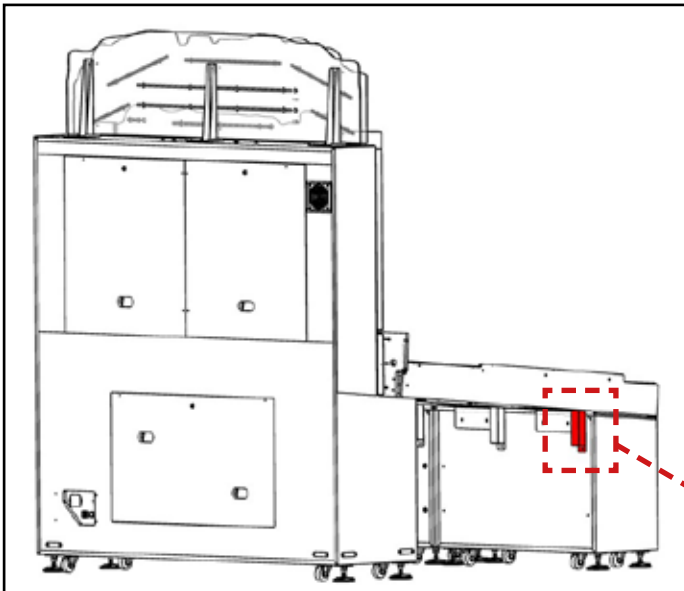

**11** Insert 1 x **PART 12** between **Player 2 and 3**. Secure using the 10 x **FIXING B** highlighted (5 fixings on each side). Attach **Harness (SIDE)** from **PART 12** to **Monitor Cab**

**PARTS USED**

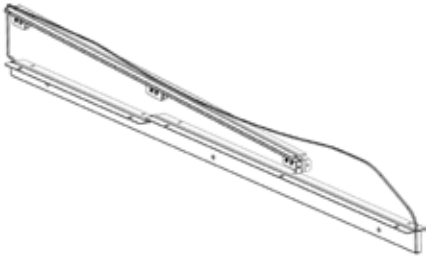

**PART 12**

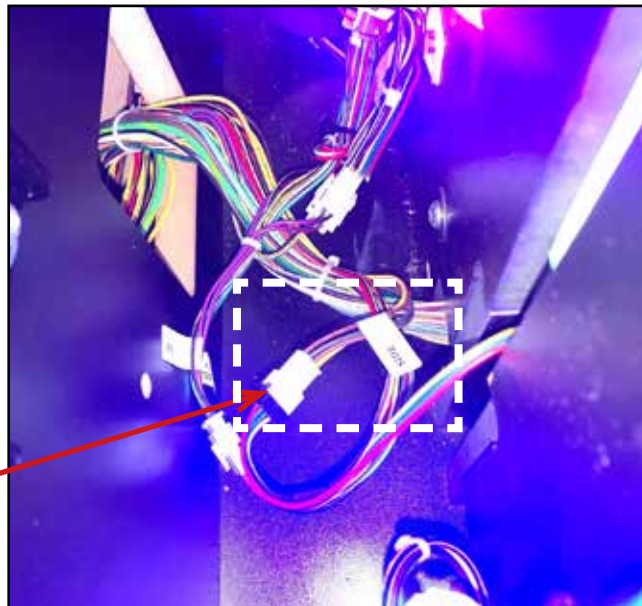
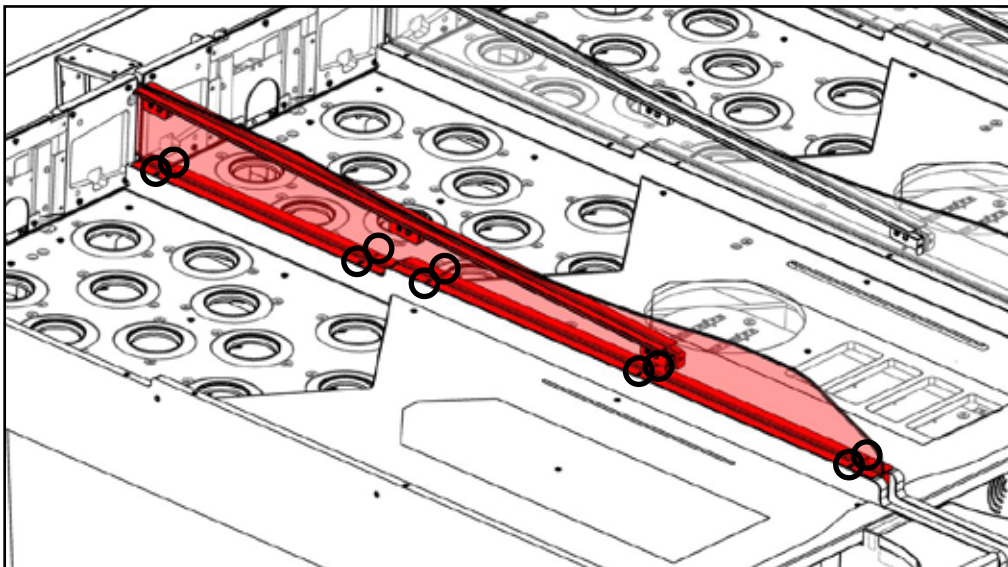

**Harness (SIDE)**



**12** Apply the **PART 14** into position and secure using **5 x FIXING A (INSIDE)** and **4 x FIXING E (OUTSIDE)**. Attach **Harness (P4 S)**

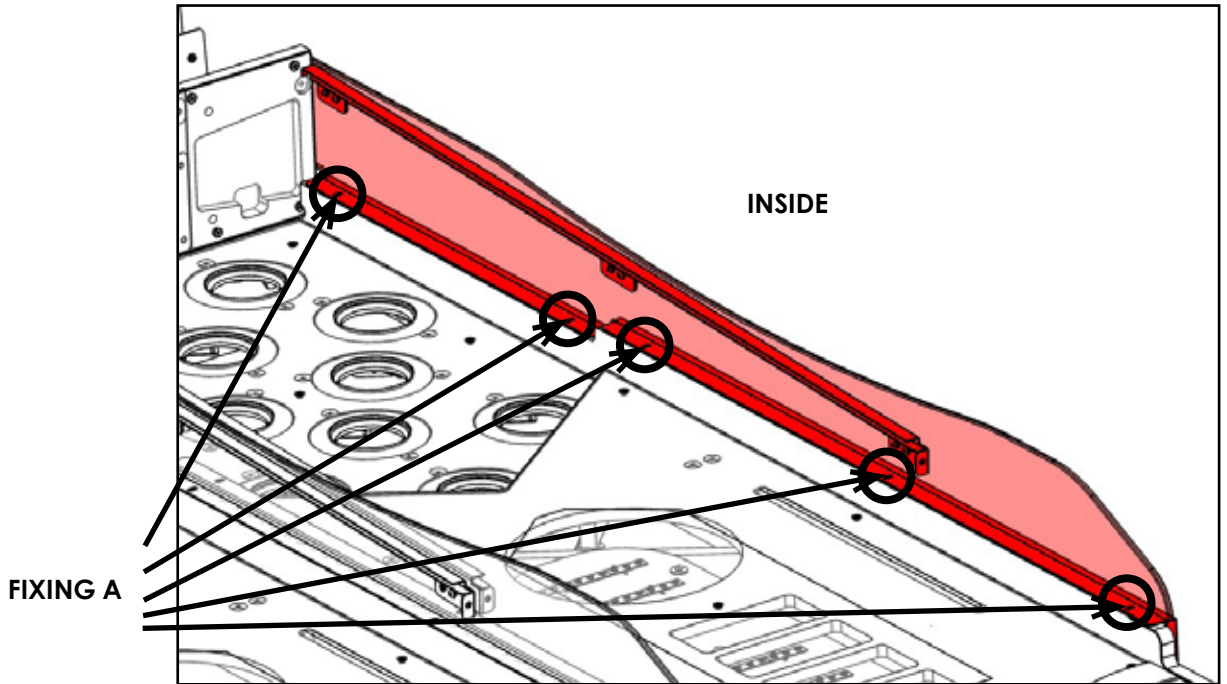
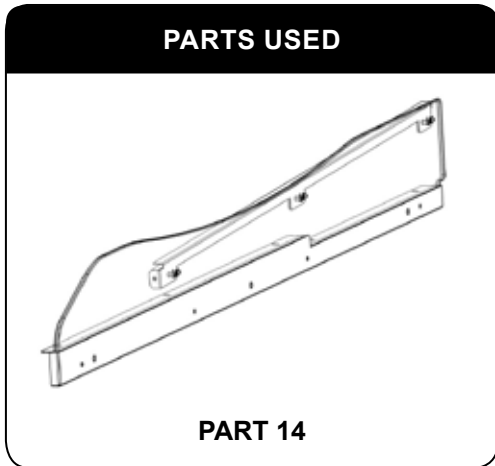

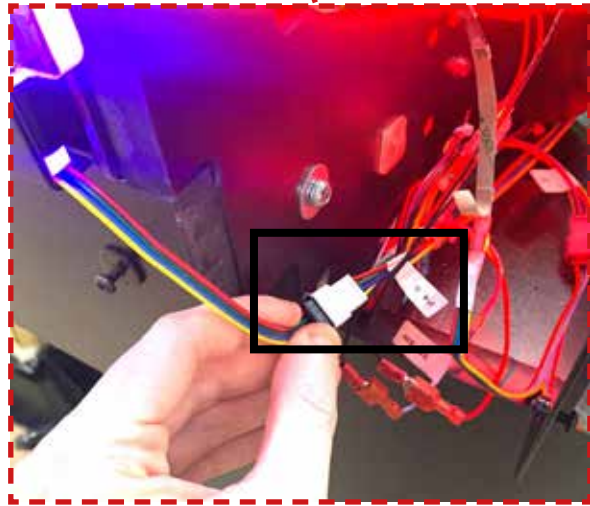
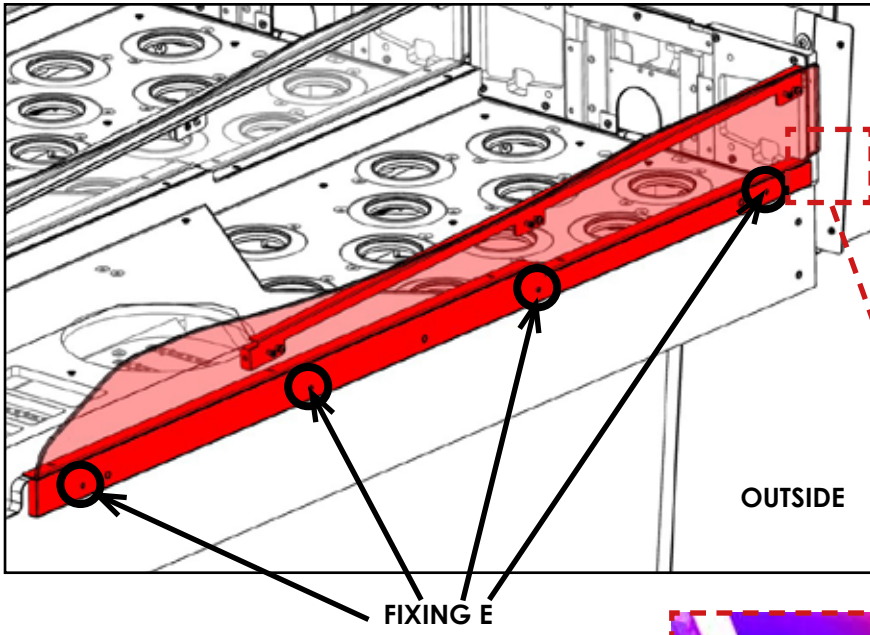

**13** Apply **PART 15** into position and secure using **5 x FIXING A (INSIDE)** and **4 x FIXING E (OUTSIDE)**.  
Connect Harness (**SIDE**)

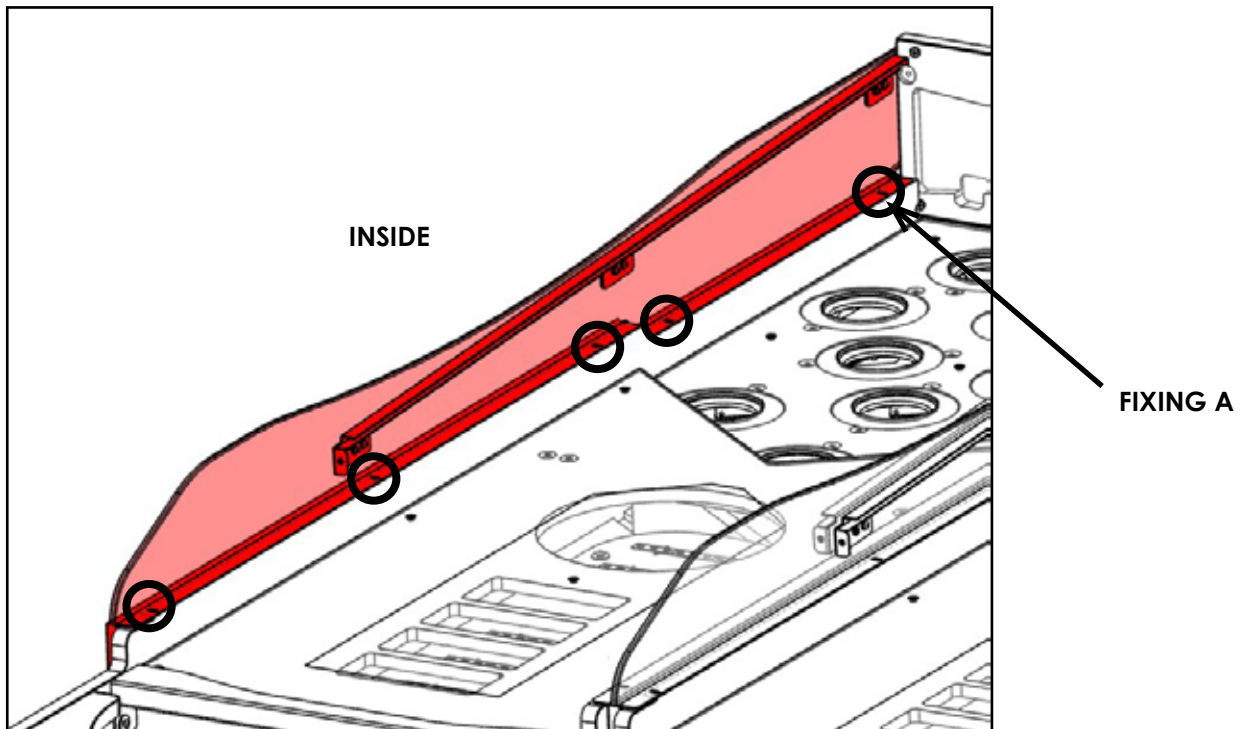
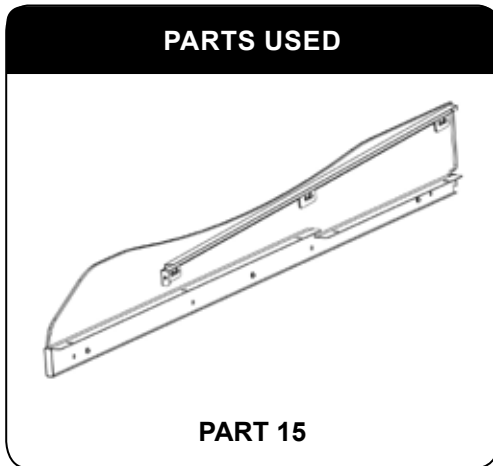

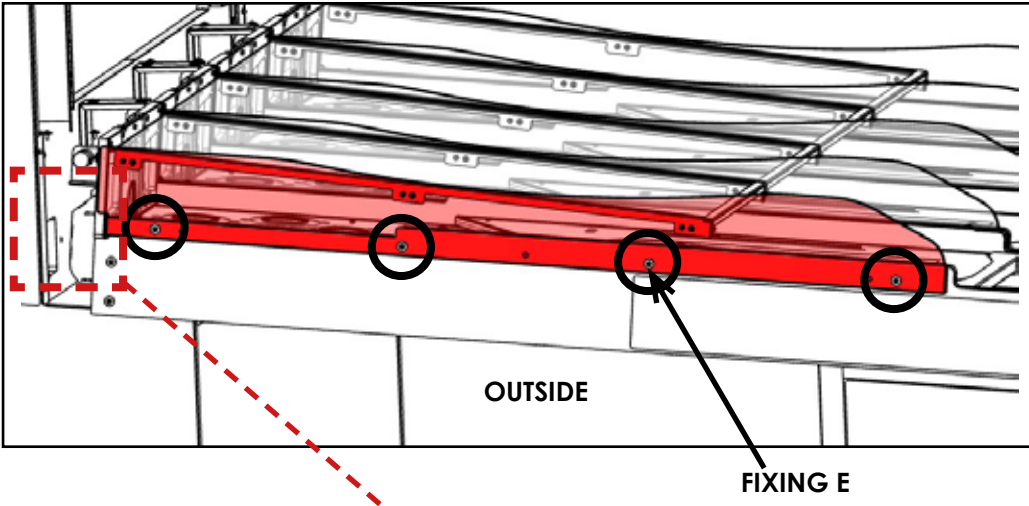

## 6-6 SUPER BONUS TEST

# IMPORTANT!

- Perform tests of the Super Bonus components before applying PART 18 & 19
- Applying PART 18 and 19 will prevent access to the Super Bonus components
- If tests do not perform as intended, consult Troubleshooting in Section 14

**1** Turn Power to the Cabinet ON

**2** Wait for the Cabinet to enter into Game

**3** Unlock and open the Coin Door on **Player 1 (BLUE)**. Press the **Test Button** on the Switch Unit to enter into Test Mode

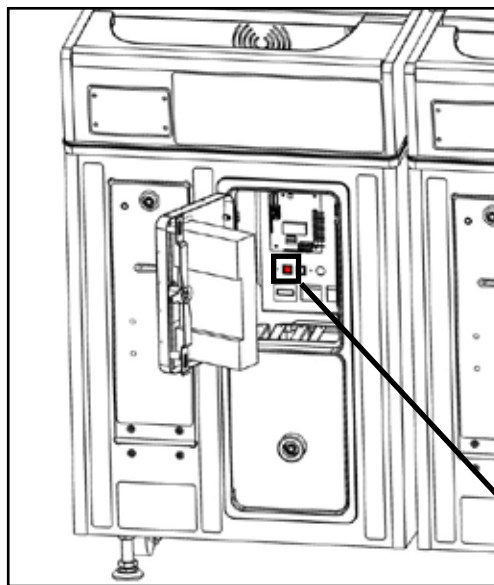

TEST BUTTON



TEST MODE

- 
- 4 Enter into the **OUTPUT TEST**. Perform the **BONUS REVEAL** and **SUPER BONUS LIGHTING** Tests for each Player (Note: **BONUS REVEAL** will change the options of **SUPER BONUS HOLE** when testing)

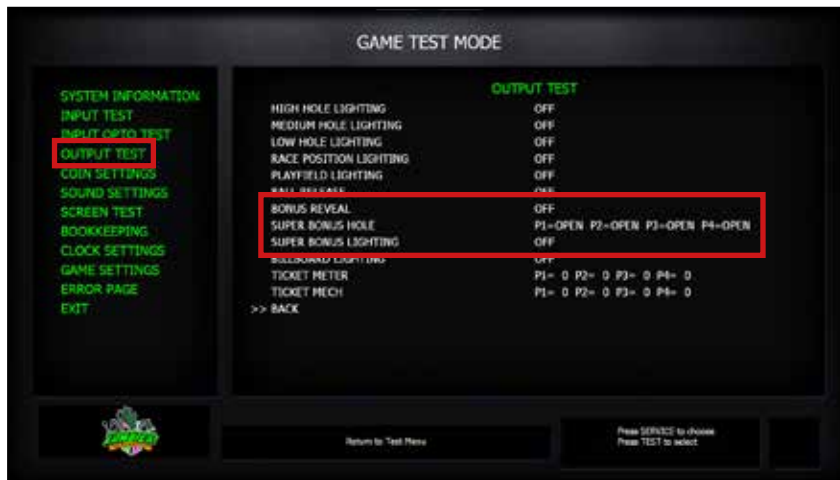

- 
- 5 Once Tests have been performed correctly, exit OUTPUT TEST and exit Test Mode

- 
- 6 Wait for Cabinet to enter into Game



- 
- 7 Turn power to the Cabinet OFF



## 6-7 INSTALLING CLOSING PLATES & PANELS

- 1 Install **PART 16 (LEFT)** and **PART 17 (RIGHT)** and secure using 3 x **FIXING B + WASHER B** on each Bracket

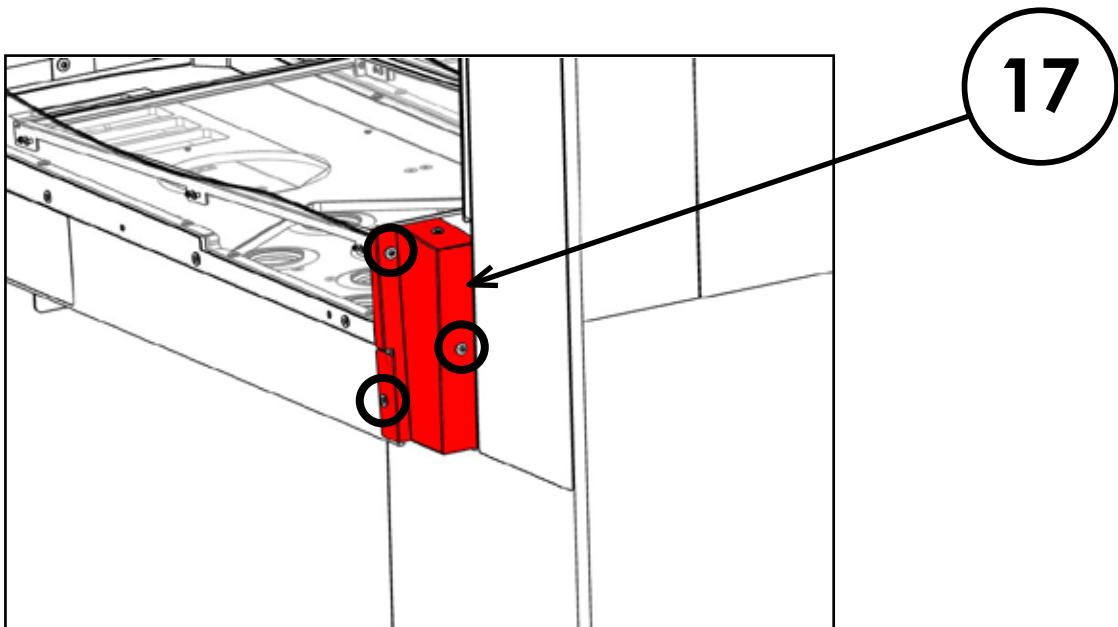
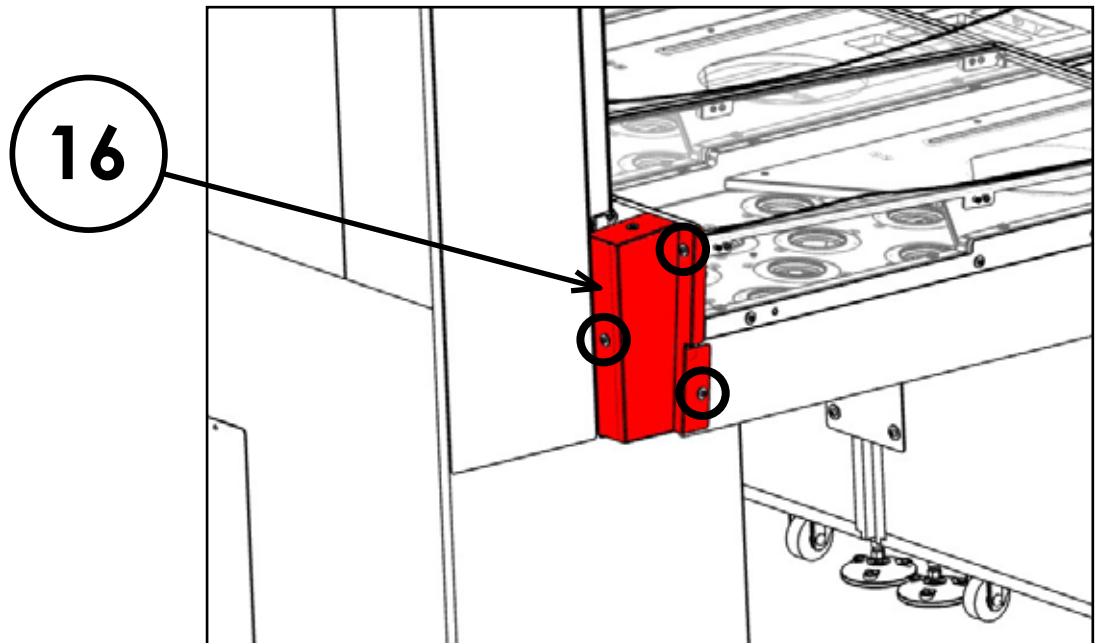
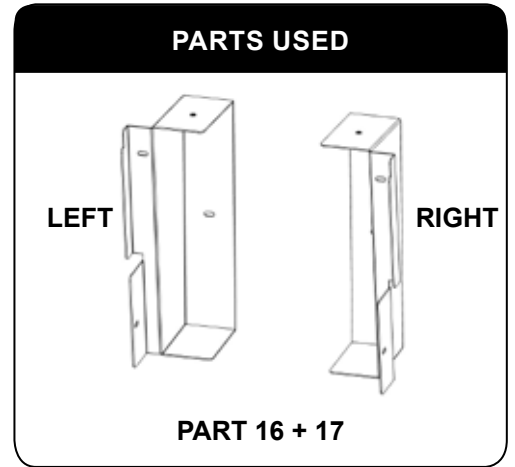

**2** Apply **PART 18 (LEFT)** & **PART 19 (RIGHT)** into position. Secure using **4 x FIXING B + WASHER B** (2 on each Bracket)

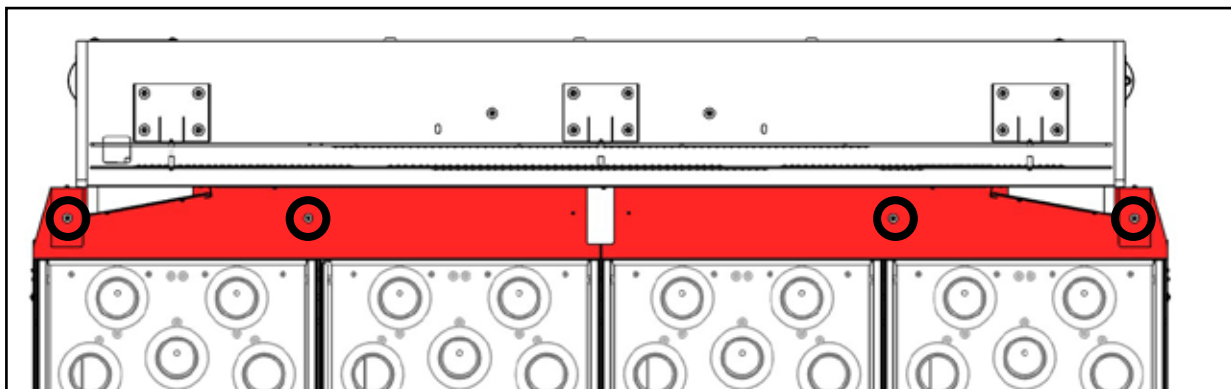
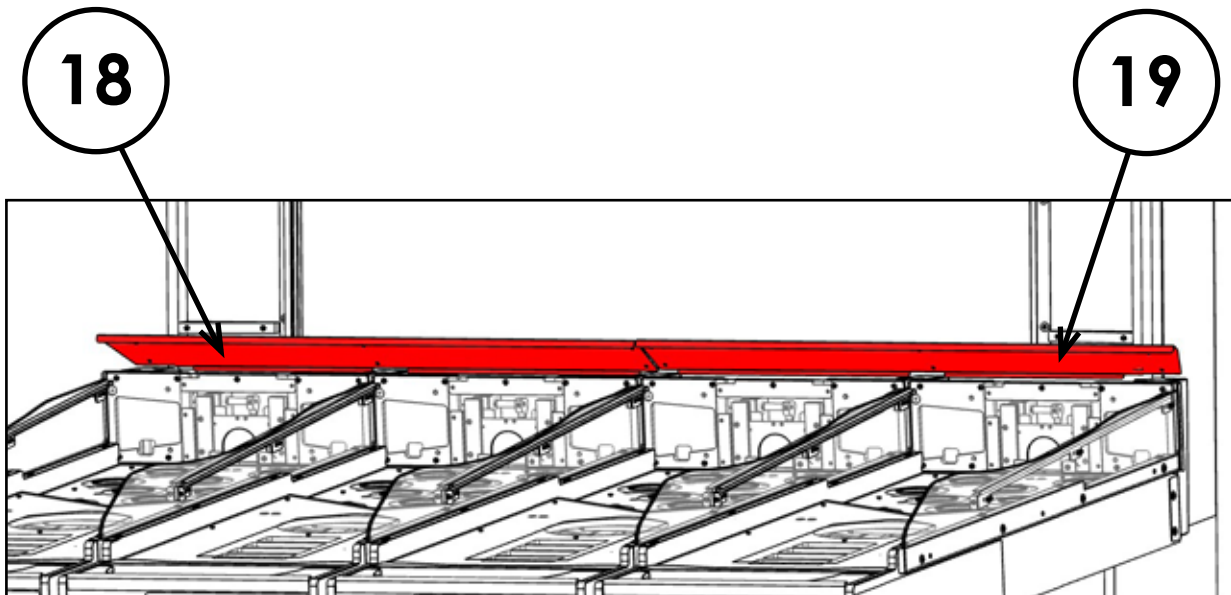
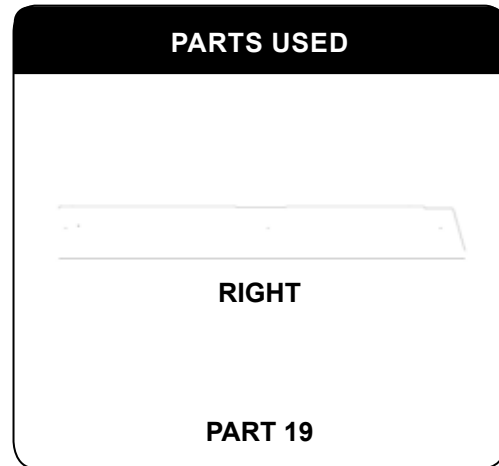
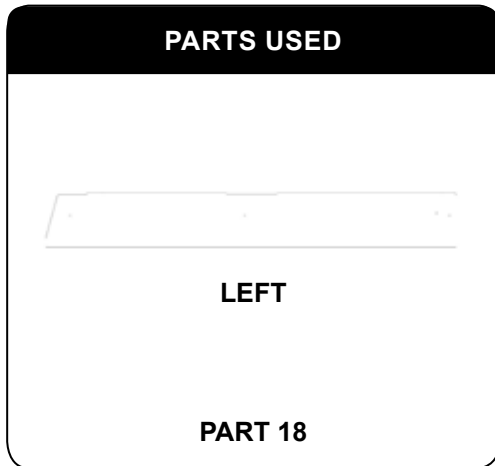



## 6-8 INSTALLING THE GLASS PANEL

- 1 Insert **PART 20** in between two brackets on **PLAYER 1 (BLUE)**

### PARTS USED

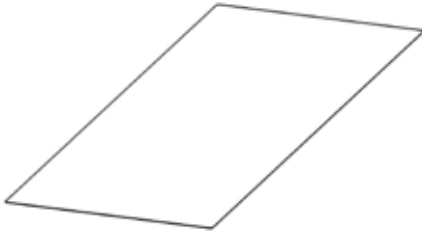

PART 20

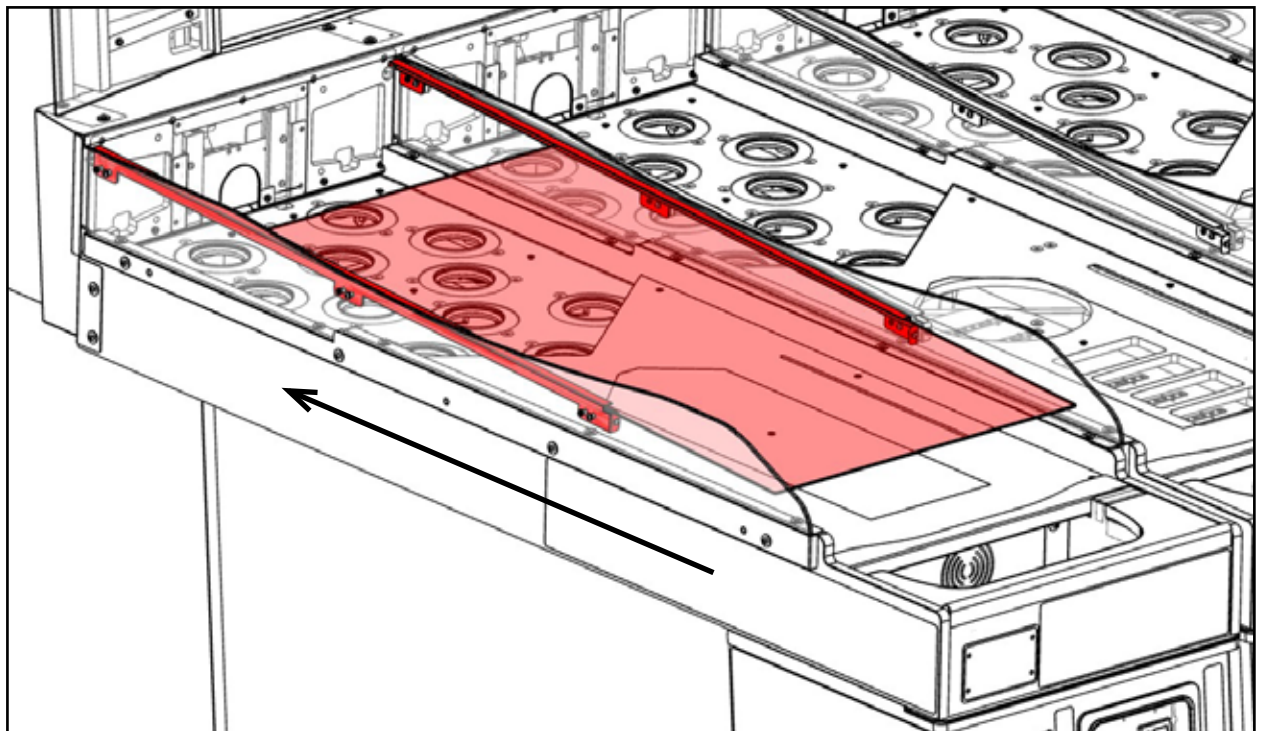

**2** Insert **PART 21** into position and secure with **2 x FIXING B + WASHER B**

**PARTS USED**



**PART 21**

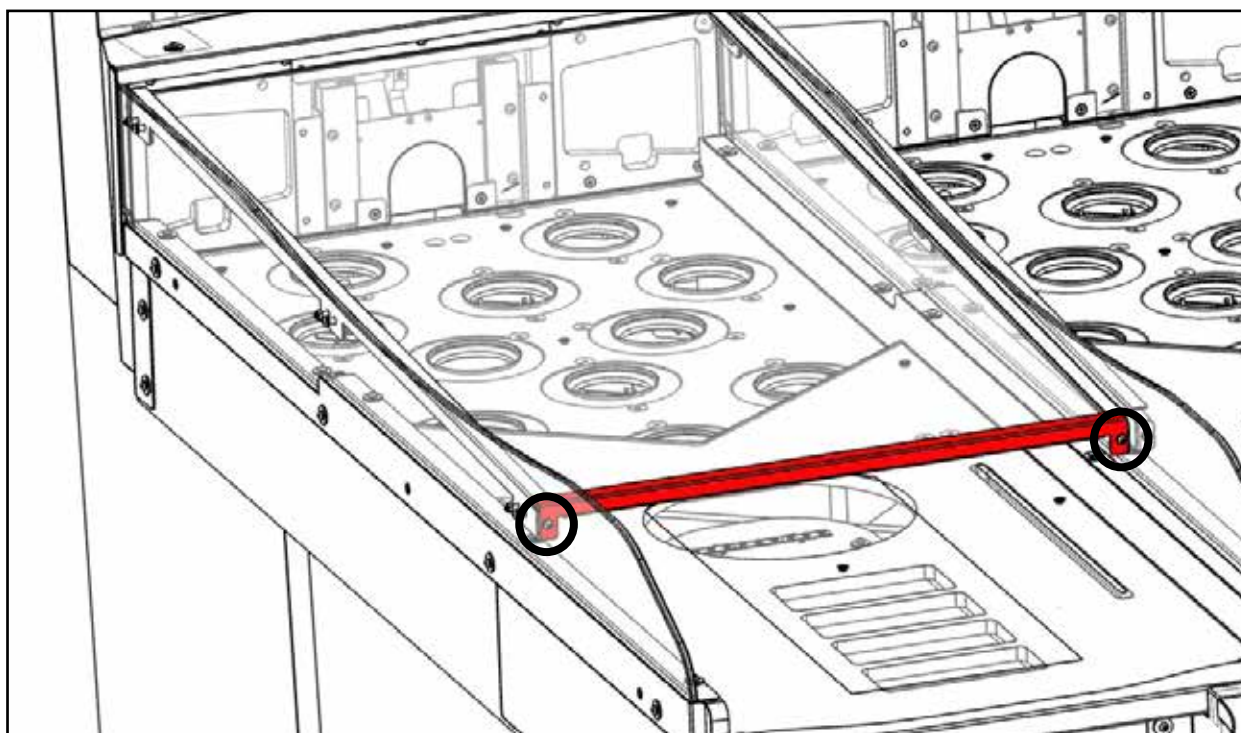

3 Repeat Steps 1 and 2 for the Players 2, 3, & 4

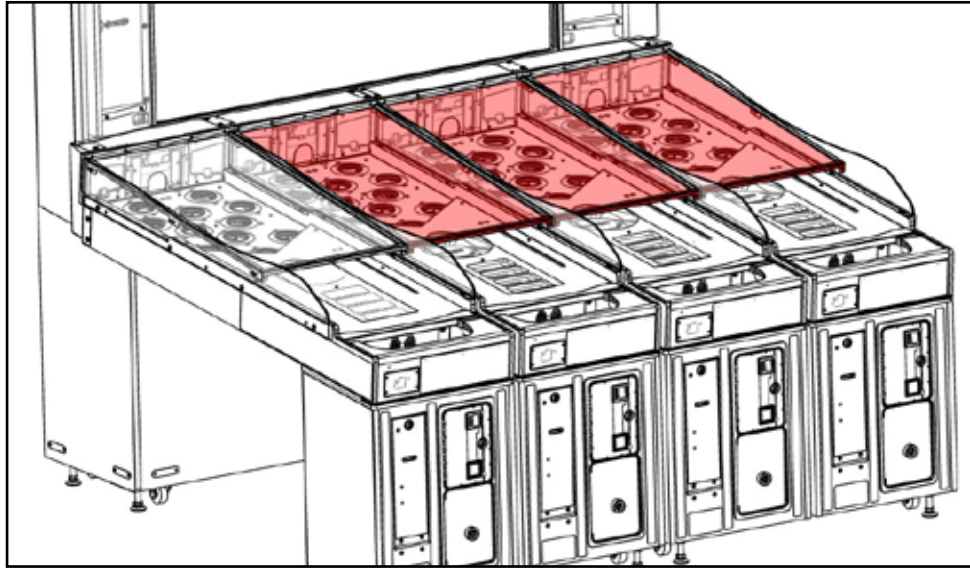

4 Play 6 Balls into the Cabinet for each Player. Retain remaining balls as spares

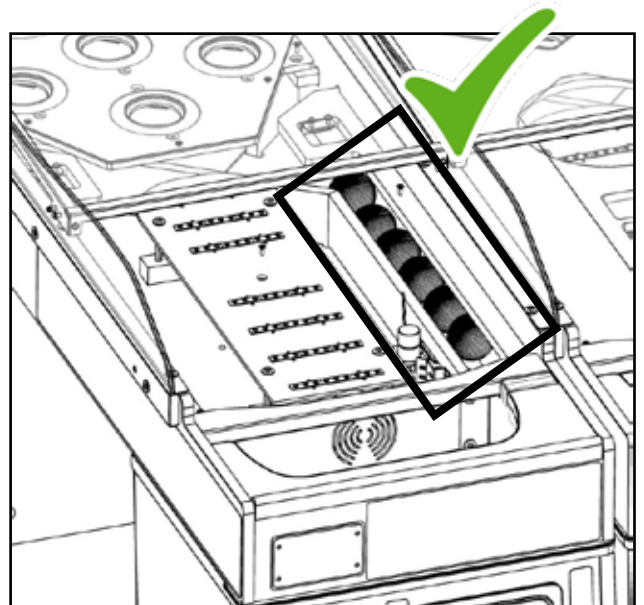
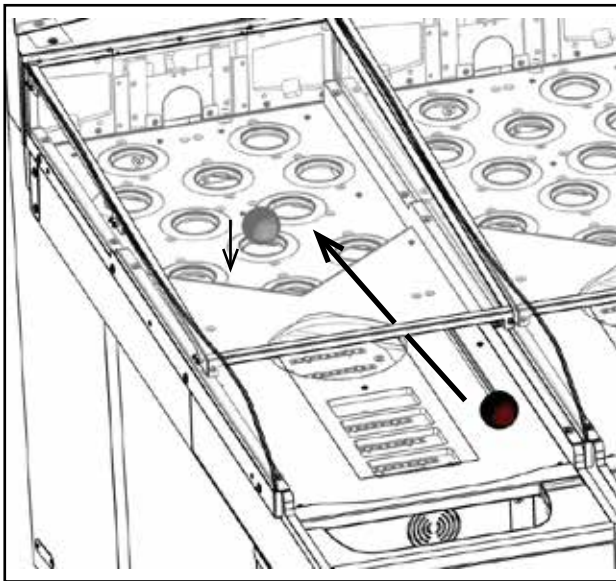

## 6-9 SECURING CABINET

### WARNING

Make sure that all the adjusters contact the floor. Otherwise the Cabinet could move, causing an accident

## IMPORTANT!

- When the installation location has been determined, ensure the adjusters come in direct contact with the floor. Establish a gap of at least 5 mm between the floor and the castors and adjust the unit so that it will remain level
- Failing to have the Cabinet level can result in errors in returning balls to the Players and impede gameplay

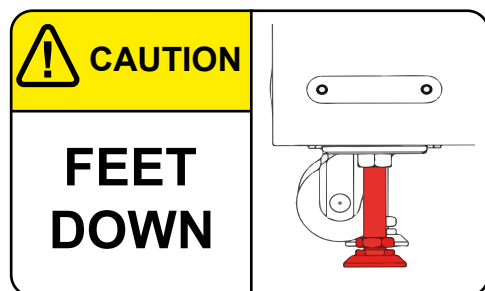

- 1 Move the product to the installation site. You must also secure a 15cm space between the back wall and the back of the Cabinet for ventilation
- 2 Bring the adjusters into direct contact with the floor. Use a wrench to align the height of the adjusters until the Cabinet is perfectly level
- 3 After setting, turn adjuster nuts upwards to tighten them and secure adjuster heights

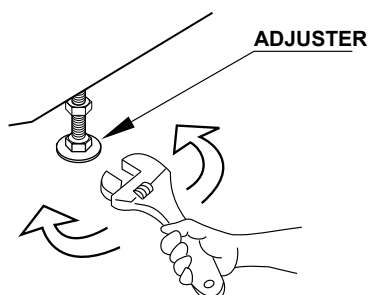

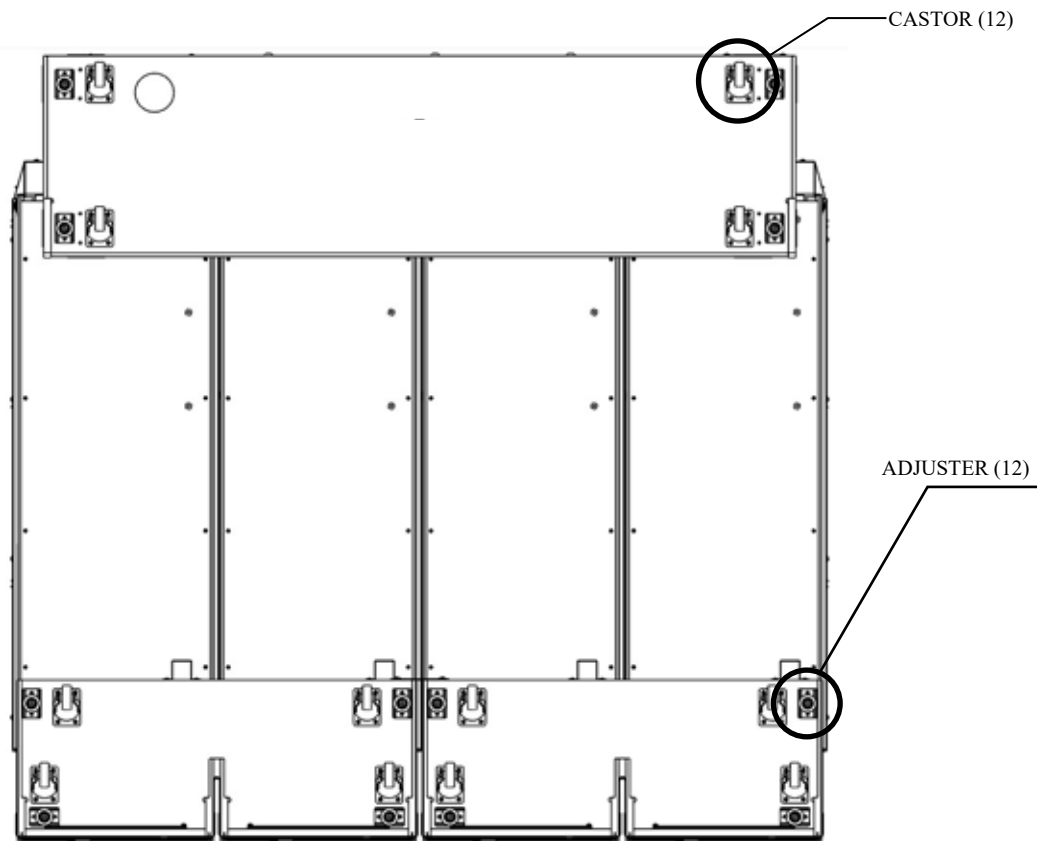

UNDERSIDE  
OF CABINET

## **STOP** IMPORTANT!

### **⚠ WARNING**

- Do not move the Cabinet as a whole after installation
- If it is required to move the Cabinet within the same location, turn power OFF, disconnect the main power lead, and remove the Playdecks
- The Cabinet can then moved as individual components of the Monitor Cab, Control Cabinets, and Playdecks

## CONNECTION OF POWER AND GROUND CABLES

(Only applies where an integral earth is not present in the mains/power lead.)

### **WARNING**

- Use the power supply equipped with an earth leakage breaker. Use of power supply without such a breaker could result in fire if there is a current leakage
- Have available a securely grounded indoor ground terminal. Without proper grounding, customers could be electrocuted and product operations might not always be stable
- Do not expose the power cord or ground wire. If these are exposed, customers could stumble over them, for instance, and easily damage them. Additionally, if these lines are damaged, there could be a risk of electrical shock or short circuit. Set these lines at locations where they will not interfere with customer traffic, or attach covers to them
- After laying out the power cord on the floor, be sure to always protect it. If the power cord is left exposed, it can easily be damaged, resulting in electrical shock
- When using the product's AC unit ground terminal, use ground wire with a circular terminal as shown in the illustration, and establish ground securely. Avoid indiscriminate grounding operations such as use of wire with only its sheath peeled off

# STOP IMPORTANT!

If grounding has been established with the ground wire inside the power cord, do not perform grounding with the AC unit ground terminal. Conversely, if the AC unit ground terminal has been used for grounding, do not establish ground with the ground wire in the power cord. Otherwise there could be faulty or erroneous operations

- 1 Confirm that the main switch is at OFF

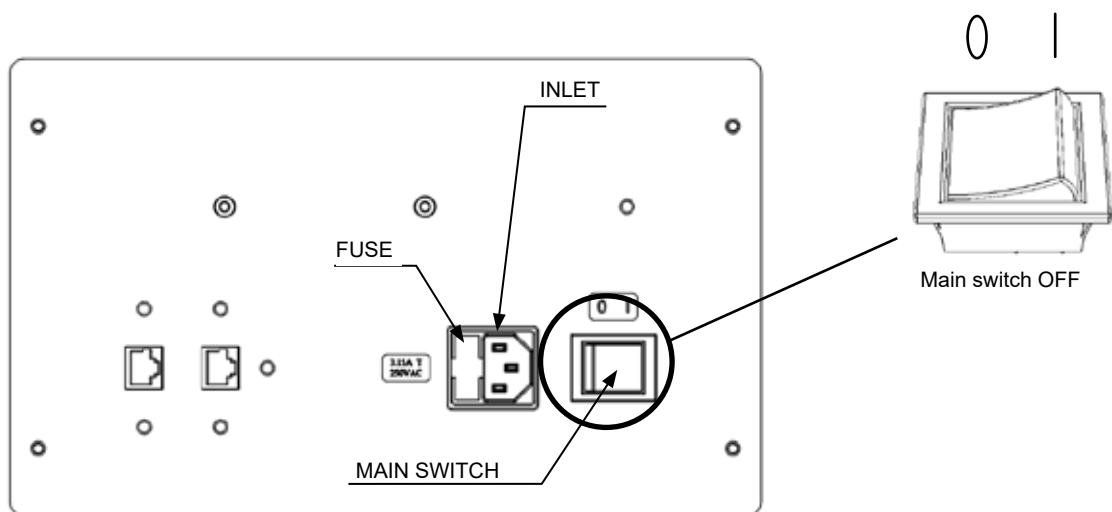

- 2 Fully insert the power cord connector on the side opposite the power plug into the AC unit inlet

- 3 Fully insert the power cord plug into the outlet

- 4 The power cord is laid out indoors. Protect the power cord by attaching wire cover to it. If ground will be established with a ground wire made available separately, lay out the ground wire indoors and have it protected

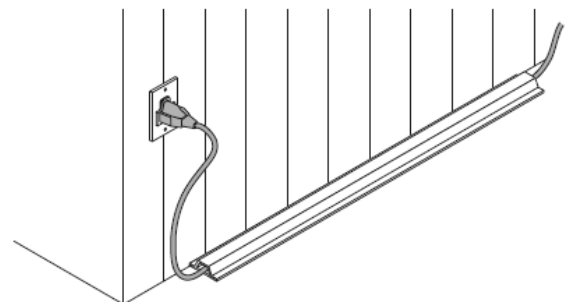



## 6-10 CONFIRMATION OF INSTALLATION

Use Test Mode to confirm that assembly is proper and that connected boards and input/output devices are normal. See Section 9 “Test and Service Data” for more information on each individual test.

Perform the following tests in Test Mode:

- 1 Unlock and open the Coin Door to access the SW Unit. Use the Test Button to enter the Test and Service Menu (any Player’s SW Unit can be used to enter/exit/select options within the test menu)

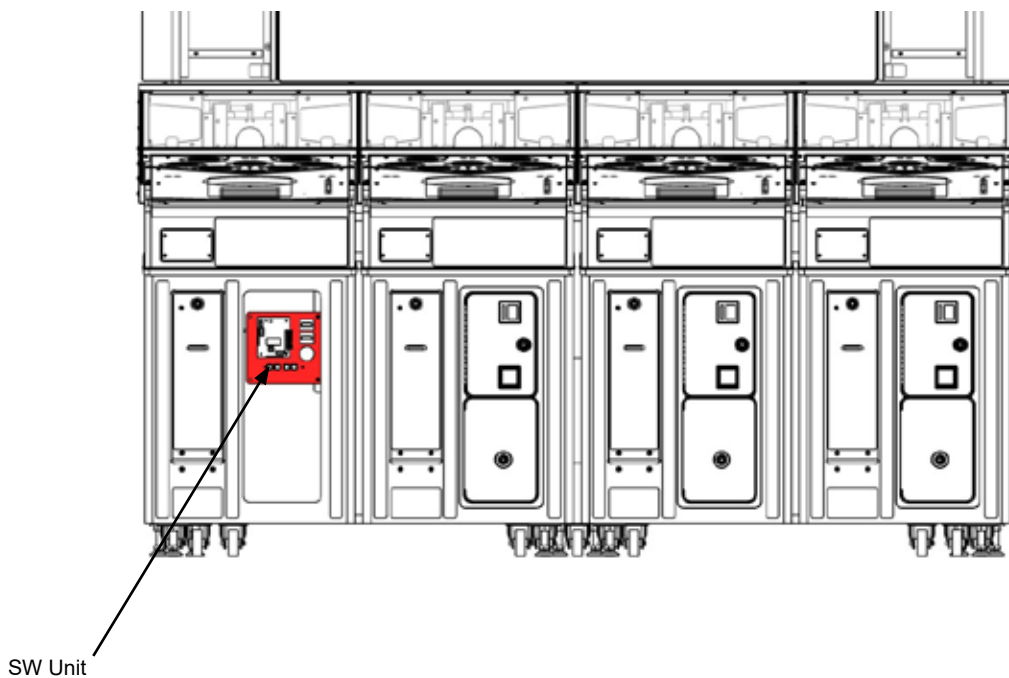

- 2 Enter the section “Input Test”. Ensure all components and Buttons are functioning correctly
- 3 Enter the section “Output Test”. Ensure all LEDs and speakers are functioning correctly

**6-11 COMPONENTS THAT CHANGE STATE UPON POWERING UP**

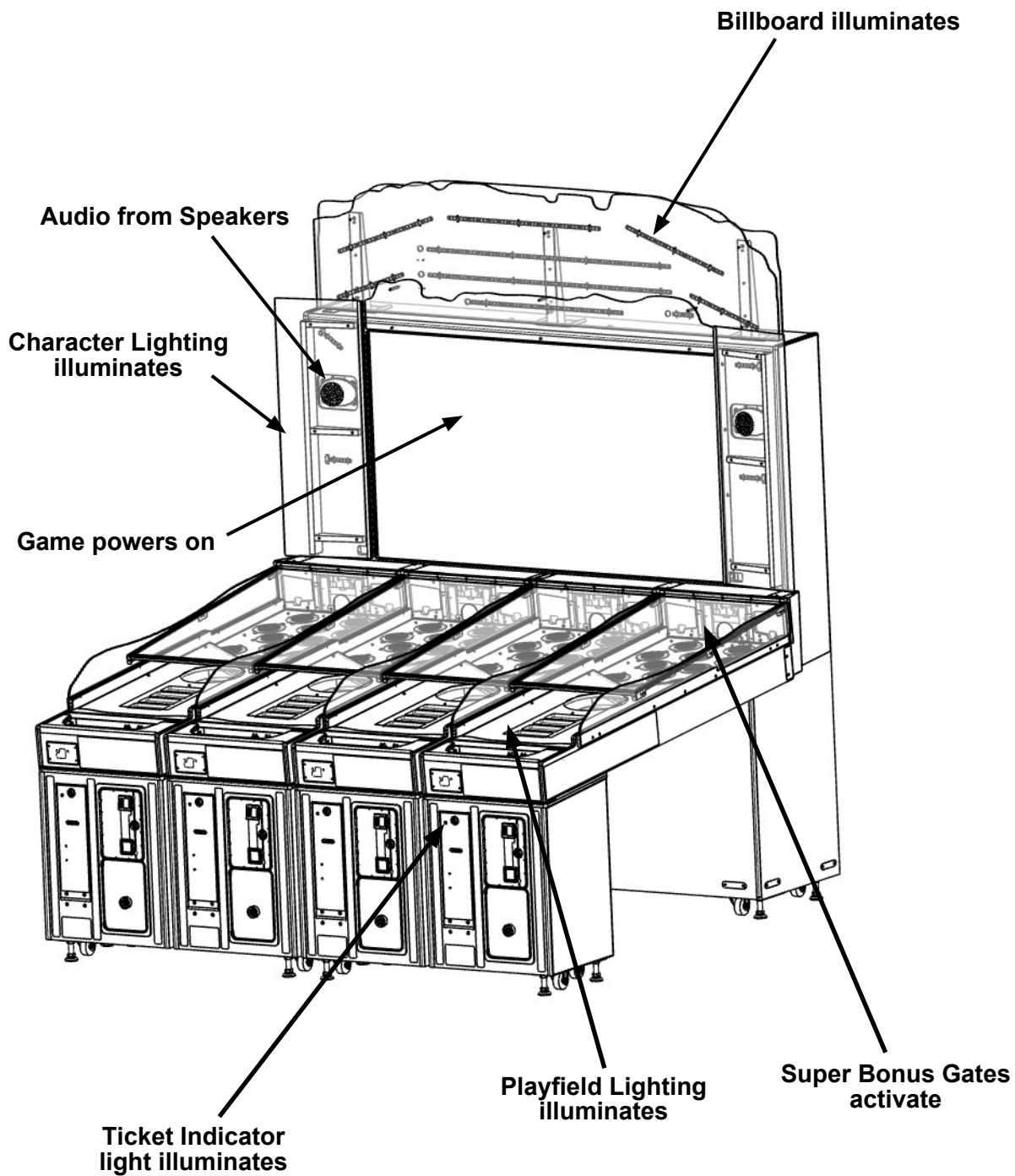

## 6-12 REPLACING TICKETS

- 1 Unlock and open the Ticket Mech Door that needs loading or replacing

Unlock Ticket Door here



- 2 Load tickets into the Ticket Holder. Feed ticket strand into the dispensing track and insert fully



- 3 Ensure tickets are vended correctly by pressing the Test Button on the Ticket Mech (tear off and remove excess tickets that are vended after testing)



- 4 Close Ticket Mech Door and ensure lock is secure

## 6-13 CARD READER INSTALLATION

1 Unlock and open the Ticket Mech Door and Coin Door

2 Remove the 4 x M4X12 fixings on the left-hand COVER PLAYDECK CORNER and remove

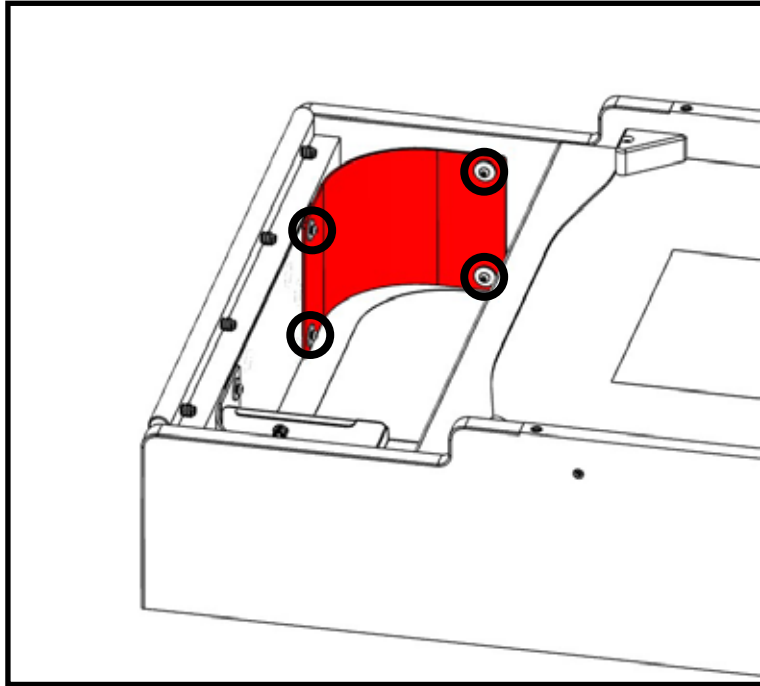

3 Remove the 2 x M4X12 fixings to remove the COVER CARD READER MOUNT

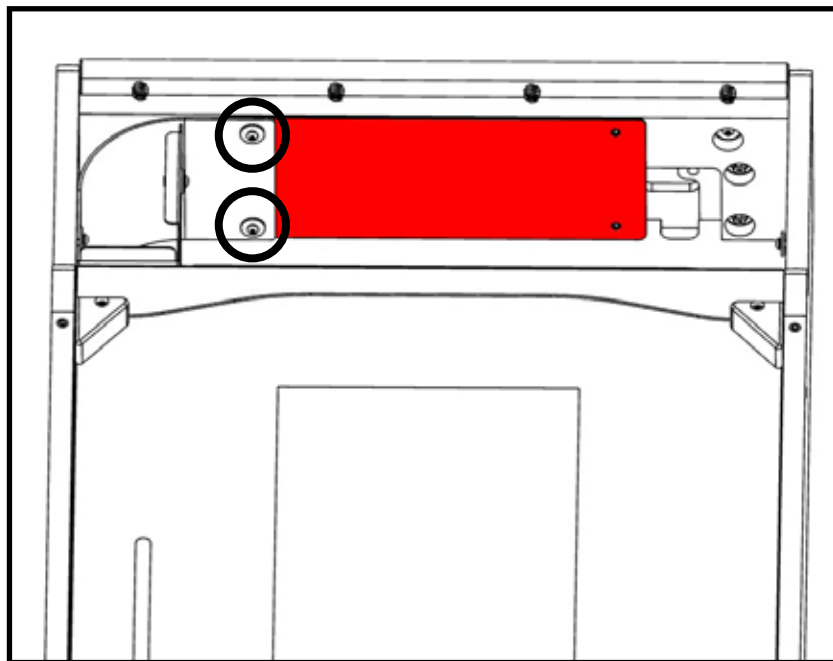

**4** Remove the 4 x M4 nuts to be able to remove the **BLANKING PLATE COVER**

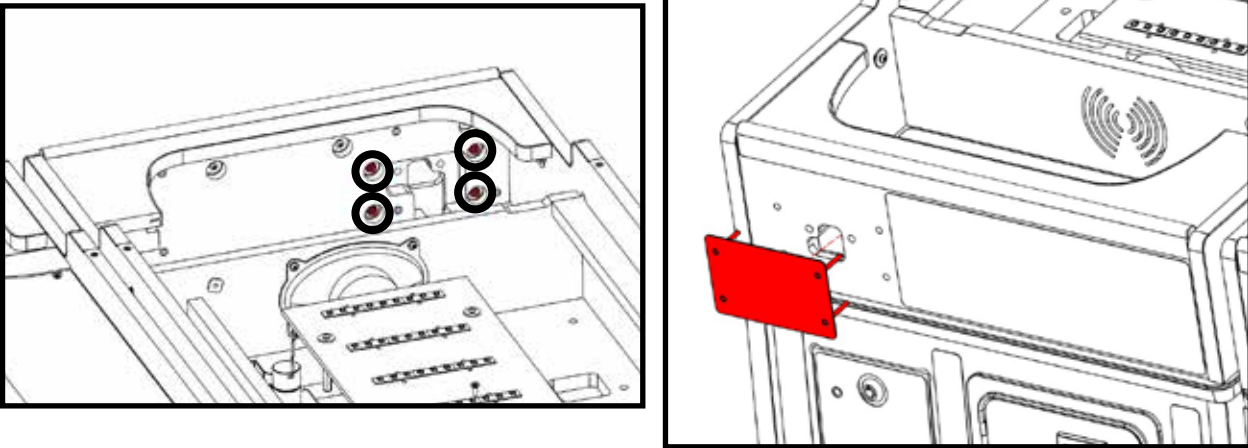

**5** Fit the Card Reader into position where the **BLANKING PLATE COVER** was

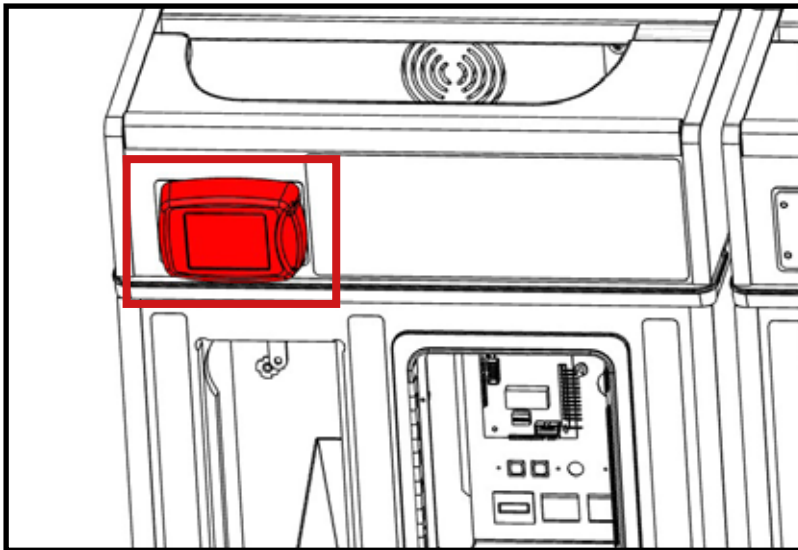

**6** Feed the harnesses from the Card Reader down through the hole in the Playdeck into the inside of the Control Cabinet

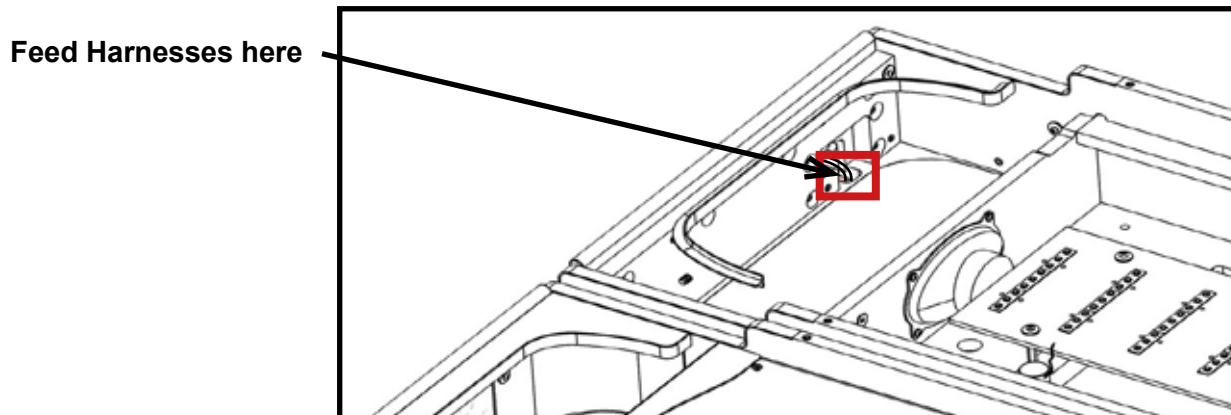



7 Connect harnesses from the Card Reader to the Ticket Mech

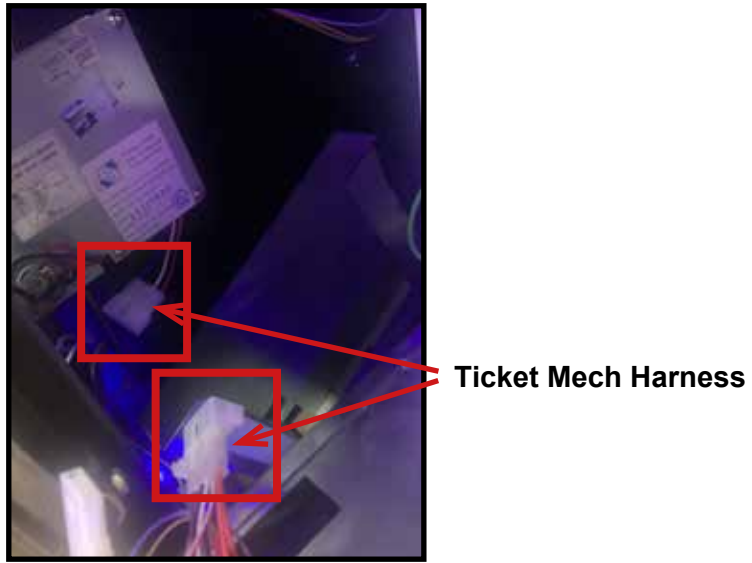

8 If you require e-tickets to be dispensed instead of physical tickets with a Card Reader fitted, **remove harness SAI-60010UK - CL NO E-TICKET ADAPTOR** and connect UCL Connector to the Switch Unit

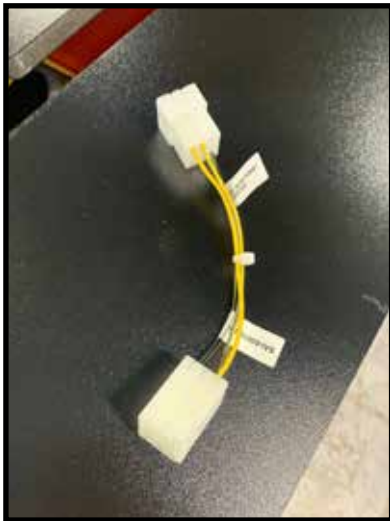

SAI-60010UK

Remove for e-tickets

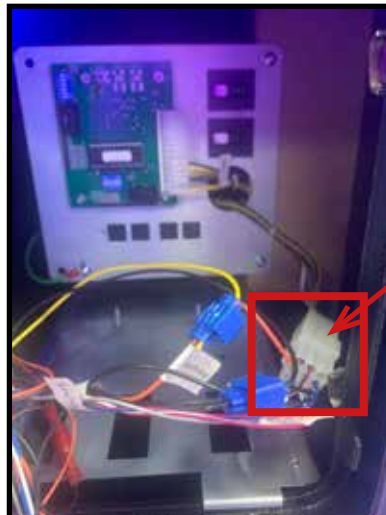

UCL Connector  
(connect to SW Unit)

**9** Enter Test Mode and proceed to **Coin Settings**. Enter Coin Settings and turn **CARD PAYMENT** to **ON** to enable e-ticket distribution



**10** Follow Steps 1 - 6 in reverse order to reapply and rescore bracketry



## **7** PRECAUTIONS WHEN MOVING

### **7-1 PRECAUTIONS OF THE MACHINE**

#### **WARNING**

- Always disconnect the power cable before moving the product. If it is moved with the power cable connected, the cable could be damaged, causing fire or electric shock
- To move the unit over the floor, pull in the adjusters and have the castors contact the floor. While moving the unit, be careful that the castors do not roll over the power cord or the ground wire. If cord or wire is damaged, there could be electrical shocks and/or short circuits
- When crossing a sloped or stepped area, disconnect the individual pieces of the Cabinet. If you tilt them while connected together, the connection points may be damaged and personnel could be injured
- When lifting the Cabinet up steps, you must hold it by the designated handles or by the bottom surface. Lifting it by any other area may lead to damage or disfiguration to that part or surrounding parts due to the weight of the Cabinet and could also lead to injury of personnel
- When tilting the Cabinet to move it across a sloped or stepped area, always use at least two people. Attempting such an operation alone can lead to accident or injury
- When moving the components separately, take care concerning the direction you push the each Cabinet section in. These elements may fall over, causing damage or an accident

#### **CAUTION**

- When moving the components, do not push any of the plastic elements or shaped parts and do not use them to pull the components along. This may damage the parts or the surrounding parts and this could lead to accidents or injury
- When moving the separated components, be sure to push/pull each Cabinet piece lengthways. Trying to move the Cabinet any other way may cause the Cabinet to topple over



# IMPORTANT!

- If you need to move components through a narrow or low door and the only way to get the separated components through is to turn them on their side, or if a separation method other than those described in this Manual is required, either make a request to the office listed in this document or the place of purchase to perform the operation or contact them regarding how to perform it. Carelessly turning the components onto their side or separating them in ways other than those depicted in this Manual may lead to irreparable damage
- Do not press any of the display screens. The screens can be easily damaged and cannot be repaired if it is, meaning complete replacement will be necessary

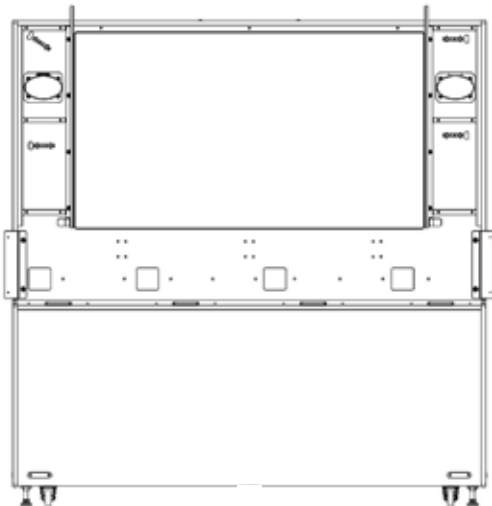

Assy Monitor Cab

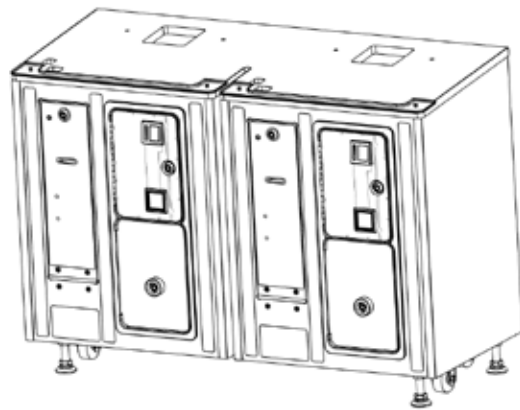

Assy Control Cab

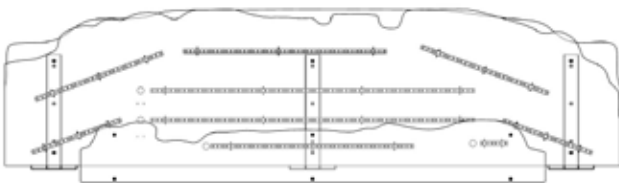

Assy Billboard

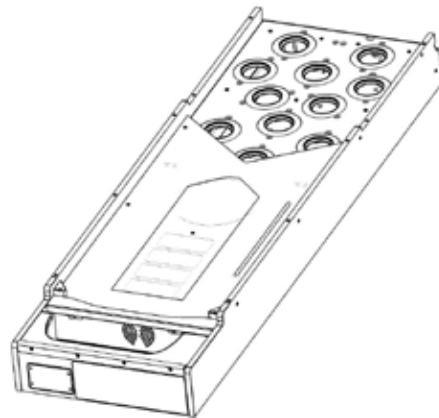

Assy Playdeck

## 7-2 MOVING THE MACHINE



# IMPORTANT!

- The Cabinet should not be moved as a single unit. Moving the Cabinet as a singular unit may incur damage to the location/surroundings and/or injury to those in the vicinity
- In order to move Cabinets, the Cheat Panels, Playfields, and Super Bonues should be disconnected from the Monitor Cabinet and their respective Control Cabinets
- Follow the Steps in Section 6 - "Assembly and Installation" in reverse order to deconstruct the Cabinet in order to move it safely

## 8 GAME DESCRIPTION

### 8-1 GAME OUTLINE

The coin system can accumulate up to 24 Credits. Credits beyond 24 will not be counted and returned to Player. **When the 24 Credit limit is reached, it will be recorded in the Test Menu under Coin Settings > Coin Count.** It will also be recorded physically on the Credit Board.

**'Zombies: Ready, Deady, Go!'** is a racing game for up to four players in which each Player repeatedly rolls nylon balls into holes on a playfield in order to make their zombie character go faster in a footrace.

The Player's goal is to maintain a fast speed and beat the other zombies in the race to achieve a high ticket pay-out.

The playfield contains eleven holes as well as a 'Super Bonus' gate. The top three 'high holes' correspond to a 'RUN' and are represented by the colour red. The middle five 'medium holes' correspond to a 'JOG' and are represented by the colour yellow. Finally, the bottom three 'low holes' correspond to a 'WALK' and are represented by the colour white.



Playfield Layout



Gameplay Screen (during Game)

The Player's aim is to increase their character's speed and maintain it. In order to keep them in first position they must get as many balls as possible into the higher ranked holes.

During the race tickets are accrued faster depending on your current position. First place will accrue the most tickets during the race. However, most of the tickets are allotted based on the Player's overall position at the end of the race.

Races run for a set amount of time, which is chosen in the Test Menu. During the final ten seconds of each race there is a 'Super Bonus chance', during this period of the game the Super Bonus gates will rapidly open and close for a short amount of time that can also be altered in the test menu.

This period is announced in the game, visually indicated by fire effects and audibly indicated by an increase in tempo of the music and the race announcer saying relevant dialogue.

If a Player manages to roll a ball through the Super Bonus gate, they will win the Super Bonus ticket value, which can be adjusted in the test menu. In the race the Super Bonus being achieved is indicated by yellow tickets overflowing over the Player's UI at the bottom of the screen, as well as a voice line from the announcer.



Players receiving a speed boost during a race

The game begins when a Player enters a Credit, then a short video will play before entering the lobby – represented by a locker room containing the four zombie characters. There are a further ten seconds in the lobby where other players can join the upcoming race by entering a Credit as well. During the lobby the Player's zombie character is introduced to them visually and via the announcer stating their name.



Lobby (Pre-race) Screen





# IMPORTANT!

**It is recommended to use 6 balls per Player. Using more than 6 balls dramatically increases the likelihood of a ball jam in the return mechanism which will prohibit play on the affected Player**

The race will then begin after a countdown and the Player(s) will roll balls into the playfield holes in order to make their zombies race for the allotted time. During the last ten seconds of the race, the 'Super Bonus' door will open and close a set number of times (determined via the test menu).

If a Player manages to roll a ball through this door during the time period when it is open, they will win the Super Bonus value that is set via the test menu.



**Results Screen**

Following this, the winner of the race is celebrated with an animation for their character and following this is a podium sequence where 1st, 2nd, 3rd, and 4th place are presented alongside the final ticket values for each Player.

After the podium display finishes, if Credits are already entered for any Players the game will load back into the lobby. If there are no Credits currently in the game, a video will play containing a ten second countdown encouraging Players to enter another Credit to continue.

If they do, the game will proceed to the lobby again. If they don't, the game will play another video, before reverting to the series of videos making up the attract portion of the game.



**End Game/Continue Screen**



## 8-2 FOUL STATES



# IMPORTANT!

- If a Player commits a foul, their lane lights will switch off and FOUL will appear over their Character name on screen
- The Player can still play the game to win tickets, but the Super Bonus will not be winnable (the Bonus Door will still open however)
- In order to reset a Player after a Foul, the game will need to cycle back to Attract mode
- If there are multiple Credits on a Player that has fouled, the Game will automatically enter into another race but the Foul will persist on the Player
- The FOUL will remain on the affected Player until the game cycles back to Attract mode
- The Game will reserve Credits on the fouled Player until the Foul has cleared

## 8-3 ERROR CODES

ERROR CODE	CAUSE	SOLUTION
1	BALL RELEASE NOT OPEN	Check Ball Release Mechanism
2	BALL RELEASE NOT CLOSED	Check Ball Release Mechanism
3	SUPER BONUS ERROR	Check Super Bonus Door
4	I/O ERROR	Check DIP Switch settings on each I/O Board

## 9 EXPLANATION OF TEST AND DATA DISPLAY

### WARNING

Do not touch any parts that are not specified in these directions. Touching unspecified locations may lead to electric shock or cause short circuits

### CAUTION

Be careful that your finger or hand does not get caught when opening/closing the coin chute door

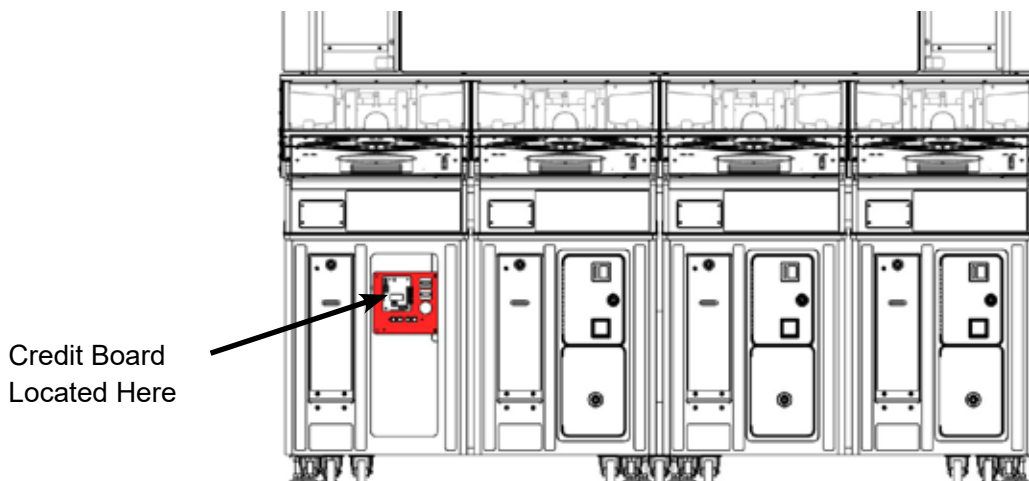

### IMPORTANT

- When you enter the Test Mode, Fractional Coin data is erased
- Adjust the sound to the optimum volume, taking into consideration the environmental requirements of the installation location
- Removing the Coin Meter circuitry renders the game inoperable

Perform tests and data checks periodically by manipulating the TEST Button and SERVICE Button in the Cabinet. Follow the instructions in this chapter to conduct checks when the game machine is first installed, when money is being collected, or when the game machine does not operate properly.

## 9-1 SWITCH UNIT AND COIN METER

The Switch Unit and Counters are housed within the Control Cabinet. To access these controls you will need to open the Coin Door. The switches and counters can be found directly on the rear face of the Tower.

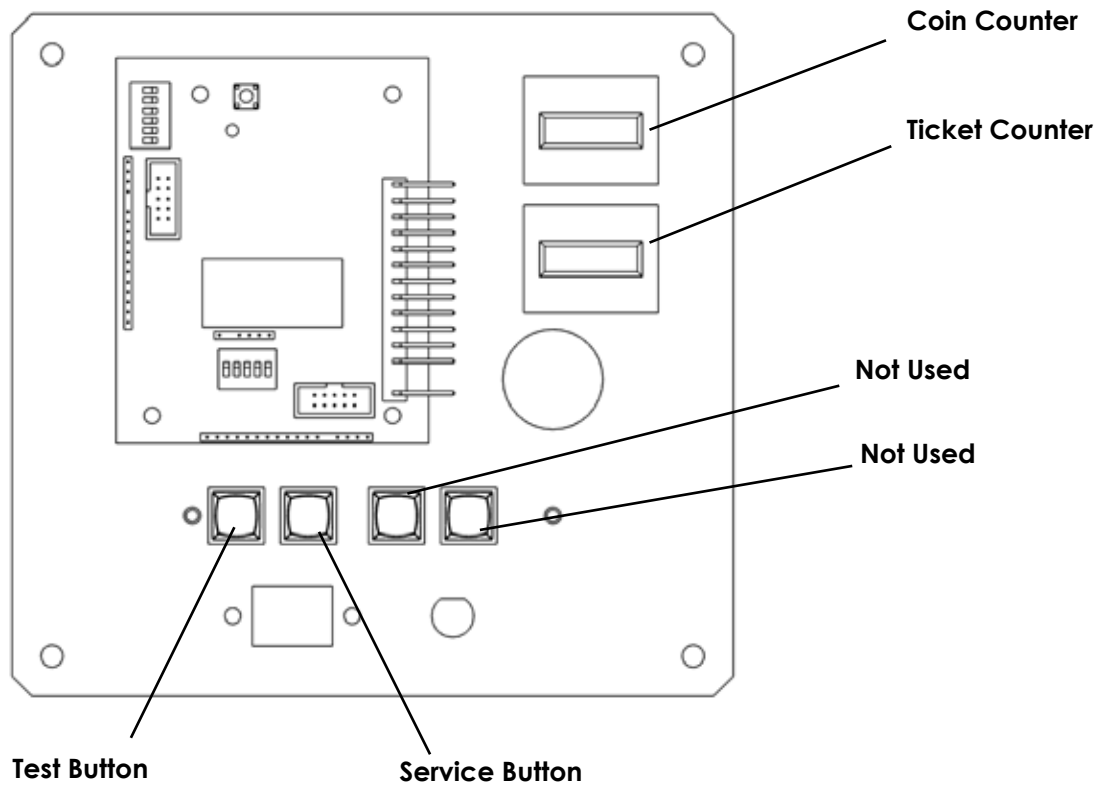

DEVICE	FUNCTION
TEST BUTTON	Press to enter TEST MODE - Also used to enter choices selected within TEST MODE
SERVICE BUTTON	Press for SERVICE CREDIT - Also used to scroll through TEST MENUS
COIN IN COUNTER	Counts inserted coins (£0.10 or \$0.10 = 1 count)
TICKET COUNTER	Counts dispensed tickets

## 9-2 GAME TEST MODE

This is the main Test Mode menu. Here you can access a number of different sub menus to test different aspects of the Cabinet to ensure they are all working correctly.



Use Service to cycle through items. Use the Test Button to select an item and view that item's sub-menu. Select EXIT to return to Game.

<b>System Information</b>	Displays software and hardware version numbers
<b>Input Test</b>	Test all input devices like Buttons and Gates
<b>Input Opto Test</b>	Tests sensors on Super Bonus and Ball Release
<b>Output Test</b>	Test all output devices like Speakers and LEDs
<b>Coin Settings</b>	Tracks all Credit entries and change Coin to Credit ratio
<b>Sound Settings</b>	Test audio elements and adjust volume levels
<b>Screen Test</b>	Test all screen variables (brightness, contrast, alignment)
<b>Bookkeeping</b>	See all Cabinet statistics (Credits, average play time, Continue Ratio, etc.)
<b>Clock Settings</b>	Adjust Cabinet internal clock
<b>Game Settings</b>	Adjust Game settings (Difficulty, Swipe Card, Super Bonus, etc)
<b>Error Page</b>	Show listed errors and error log

## 9-3 SYSTEM INFORMATION

This menu details aspects of the software information. Use the Service button to cycle through the options and the Test button to select an option



<b>Game Name</b>	Name of installed game software
<b>Game Version</b>	Game software version number
<b>Disk Image Version</b>	Disk Image version of Game Board
<b>Launcher Version</b>	Software Launcher version number
<b>Shell Version</b>	Game Shell version number
<b>IO Board Firmware version</b>	Version number for IO Firmware(s)
<b>Security Key</b>	Displays whether Security Key is detected/correct, missing, or invalid
<b>Machine ID</b>	ID Number for Cabinet
<b>Reset to Factory Defaults</b>	Restore all settings to defaults set at factory prior to shipping (requires confirmation)
<b>Back</b>	Return to Main Test Menu

## 9-4 INPUT TEST

This menu details the functionality of things like playfield score zones, coin and ticket devices, and Test & Service Buttons.

To exit this menu, press the Test and Service Button simultaneously

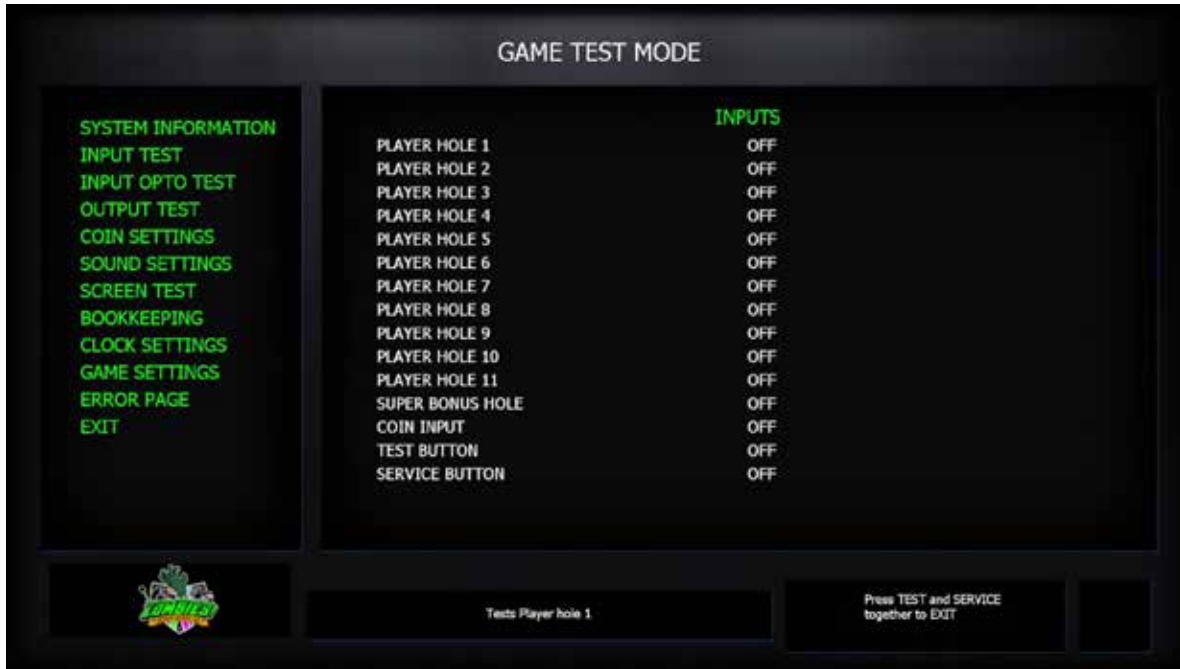

<b>Player Hole 1-11</b>	This setting is a visual indicator of inputs for all general Player holes. Inserting a ball into any of the players holes will turn the matching player hole on screen from <b>OFF</b> to <b>ON</b>
<b>Super Bonus Hole</b>	Indicator for if the Super Bonus hole is functional
<b>Coin Input</b>	Pressing the coin input will turn the visual indicator from <b>OFF</b> to <b>ON</b>
<b>Test Button</b>	Pressing the test button will turn the visual indicator from <b>OFF</b> to <b>ON</b>
<b>Service Button</b>	Pressing the service button will turn the visual indicator from <b>OFF</b> to <b>ON</b>



## 9-5 INPUT OPTO TEST

This menu details the functionality of things like playfield lighting and ticket meters.

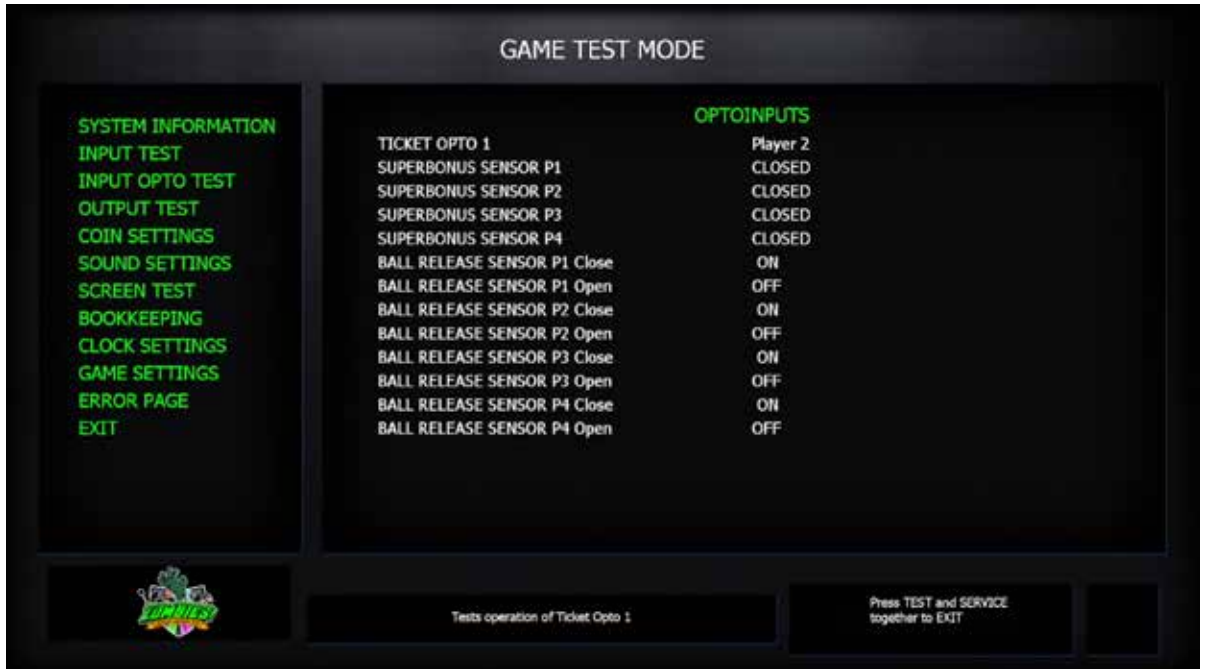

<b>Ticket Opto 1</b>	Tests the Ticket Opto on each Player by vending a single ticket
<b>Super Bonus Sensor P1-4</b>	Displays current state of Super Bonus door for respective Player
<b>Ball Release P1/2/3/4 Close</b>	Tests whether mechanical input matches software input for Ball Release Close on respective Player
<b>Ball Release P1/2/3/4 Open</b>	Tests whether mechanical input matches software input for Ball Release Open on respective Player
<b>Back</b>	Return to Main Test Menu

## 9-6 OUTPUT TEST

This menu details the functionality of things like playfield score zones, coin and ticket devices, and Test & Service Buttons. To exit this menu, press the Test and Service Button simultaneously

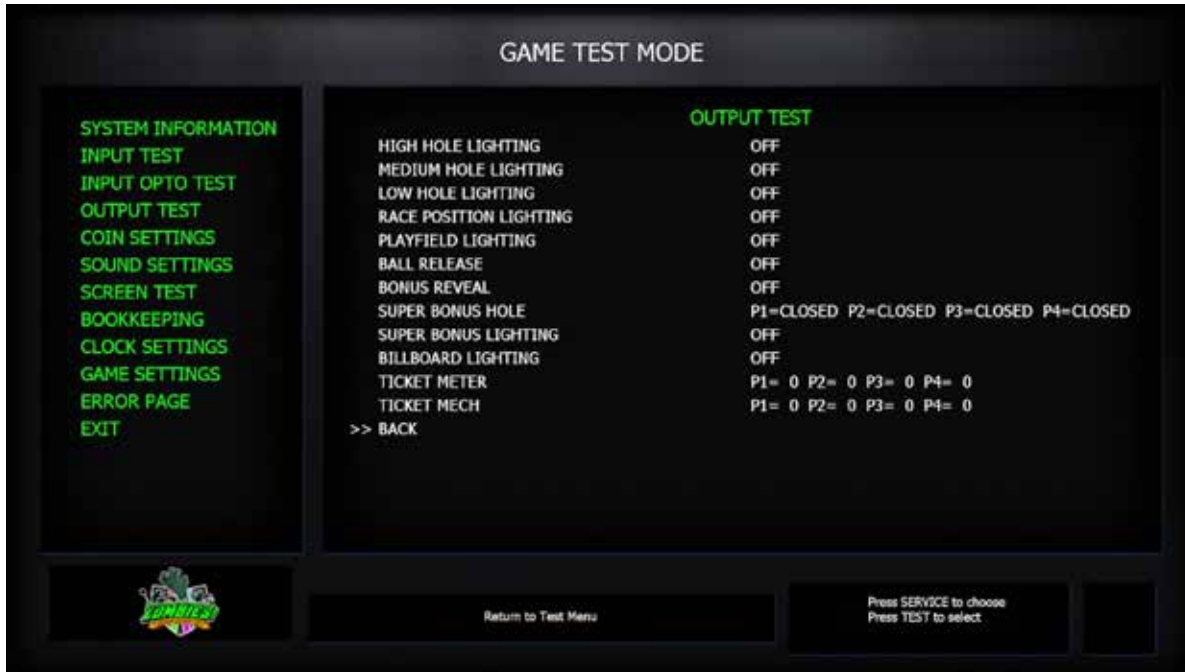

<b>High Hole Lighting</b>	Test colour sequence for RUN lighting holes
<b>Medium Hole Lighting</b>	Test colour sequence for JOG lighting holes
<b>Low Hole Lighting</b>	Test colour sequence for WALK lighting holes
<b>Race Position Lighting</b>	Test colour sequence for Race Position lighting
<b>Playfield Lighting</b>	Test colour sequence for Playfield lighting
<b>Ball Release</b>	Test functionality of Ball Release mechanism
<b>Bonus Reveal</b>	Test functionality of Bonus mechanism
<b>Super Bonus Lighting</b>	Test colour sequence for Super Bonus lighting
<b>Billboard Lighting</b>	Test colour sequence for Billboard lighting
<b>Ticket Meter P1-4</b>	Test functionality of Ticket Meter for respective Player (adds 1 to Ticket Counter on SW Unit)
<b>Ticket Mech P1-4</b>	Test functionality of Ticket Mech for respective Player (vends 1 ticket for respective Player)
<b>Back</b>	Return to Main Test Menu

## 9-7 COIN TEST

This menu details the number of regular and service credits the Cabinet has received, and allows the amendment of the coin to credit ratio.



<b>Coin Count</b>	Amount of Coins the Cab has received on each Player
<b>Credits</b>	Amount of standard Credits the Cab has received on each Player
<b>Service Credits P1-P4</b>	Amount of Service Credits the Cab has received on each Player
<b>Card Payment</b>	Set whether Card Payment is active for cashless machines
<b>Game Cost</b>	Set Cost of Game from Attract
<b>Continue Cost</b>	Set Cost of Continue Game
<b>Credit Setting</b>	Set Coin to Credit ratio
<b>Setting 1</b>	1 Coin - 1 Credit
<b>Setting 2</b>	2 Coins - 1 Credit
<b>Setting 3</b>	3 Coins - 1 Credit
<b>Setting 4</b>	4 Coins - 1 Credit
<b>Setting 5</b>	5 Coins - 1 Credit
<b>Setting 6</b>	1 Coin - 2 Credits
<b>Setting 7</b>	1 Coin - 3 Credits
<b>Setting 8</b>	1 Coin - 4 Credits
<b>Setting 9</b>	1 Coin - 5 Credits
<b>Setting 10</b>	Freeplay
<b>Back</b>	Return to Main Test Menu

## 9-8 SOUND TEST

This menu allows the testing of audio devices and changing of the standard and attract volume level.



<b>In-Game Audio</b>	Set Volume level for music and in-game sound effects (10-100)
<b>Attract Volume</b>	Set Volume level for attract sequence (10-100)
<b>P1-P4 Volume</b>	Individually changes the volume for each player (speaker in ball return area) (10-100)
<b>Boost Announcer</b>	Sets if there is an audio boost for Announcer's voice lines (ON-OFF) = <b>ON</b>
<b>Speaker Test</b>	Tests all speakers individually
<b>Back</b>	Return to Main Test Menu

## 9-9 SCREEN TEST

This menu allows the adjustment of screen variables.

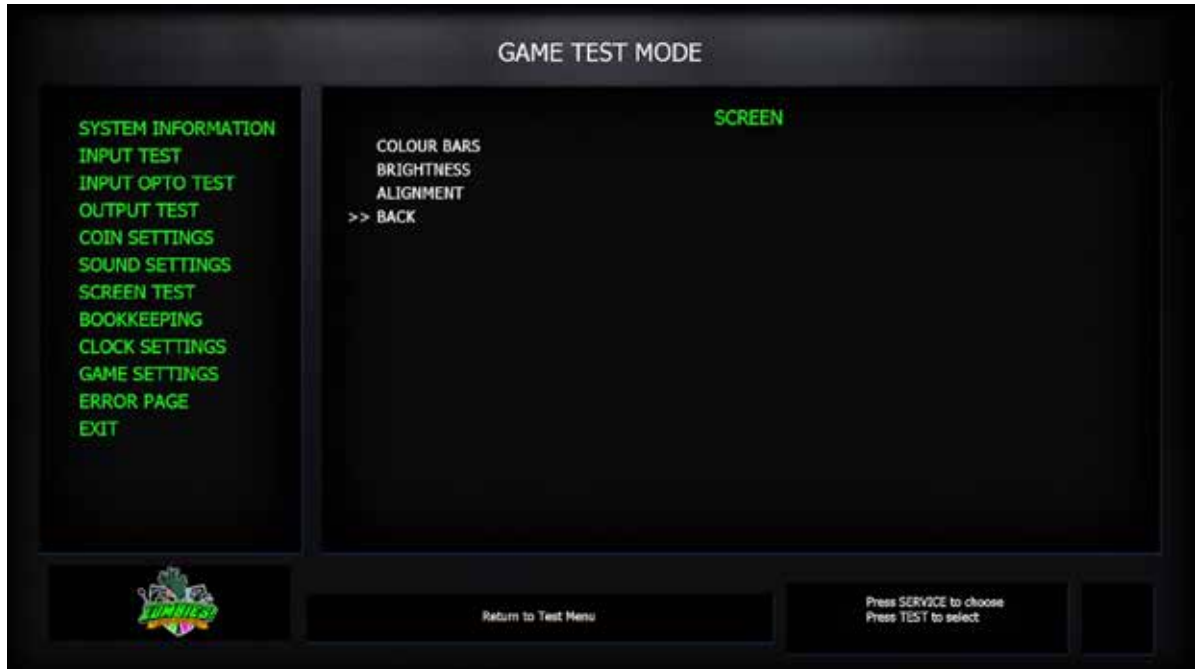

### Colour Bars:

Selecting this will display the following screen:

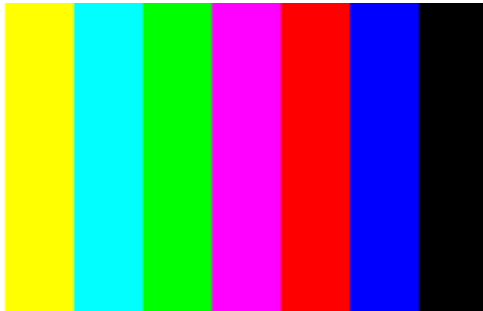

### Brightness:

Selecting this will display the following screen:



### Grid Alignment:

Selecting this will display the following screen:

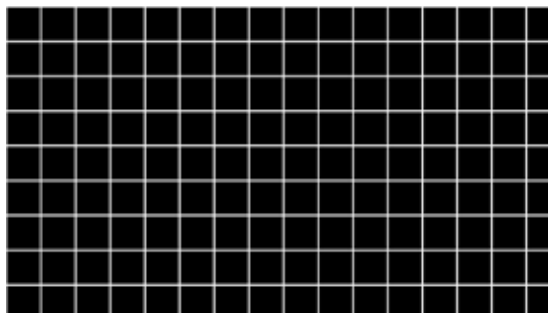

## 9-10 BOOKKEEPING

These menus detail Cabinet statistics. The first menu shows total credits and allows for the clearing of the Bookkeeping logs.



<b>Coin Credits</b>	Amount of Coin Credits the Cab has received
<b>Service Credits</b>	Amount of Service Credits the Cab has received
<b>Total Credits</b>	Total amount of Credits the Cab has received
<b>Bookkeeping Last Cleared</b>	Date/Time stamp of the last time Bookkeeping was cleared
<b>Clear Bookkeeping</b>	Clear all Bookkeeping statistics (requires confirmation)
<b>Next Page</b>	Proceed to Bookkeeping Page 2
<b>Back</b>	Return to Main Test Menu



This menu details the plays and continues for each player.

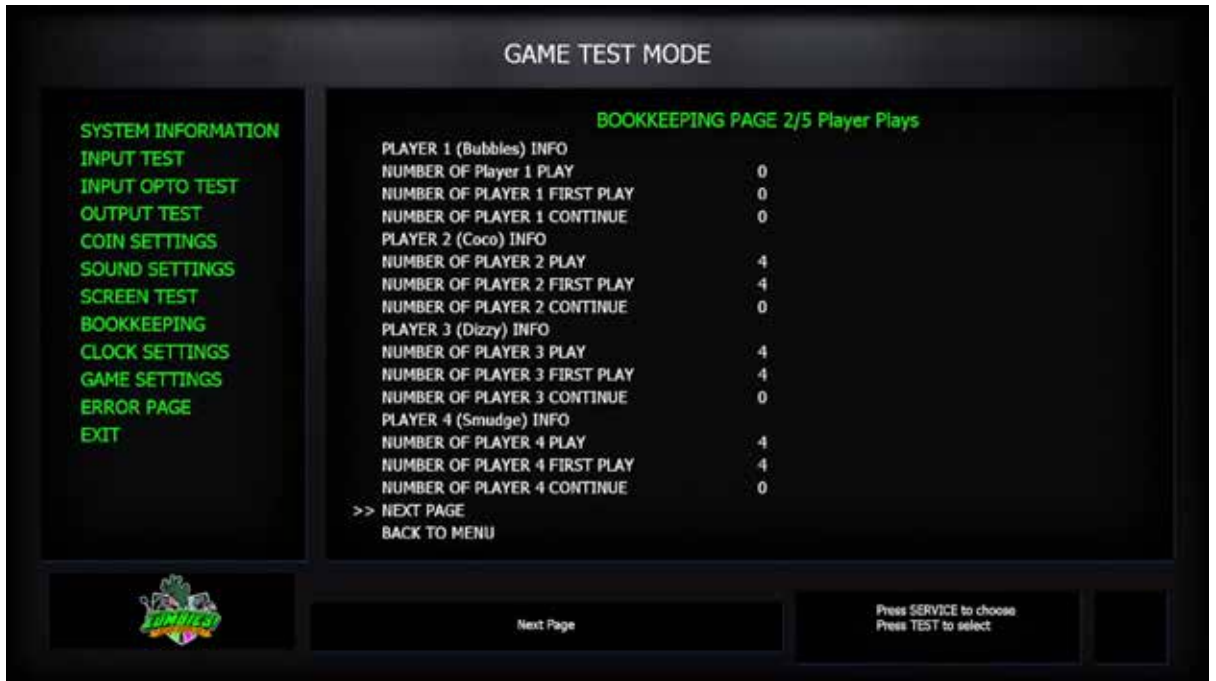

<b>Player X Info</b>	Play info for following Player
<b>Number of Player X Play</b>	Number of total games from this Player
<b>No of Player X First Play</b>	Number of games started from this Player
<b>No of Player X Continue</b>	Number of continues started from this Player
<b>Next Page</b>	Proceed to Bookkeeping Page 3
<b>Back</b>	Return to Main Test Menu

This menu details the combination of types of plays.

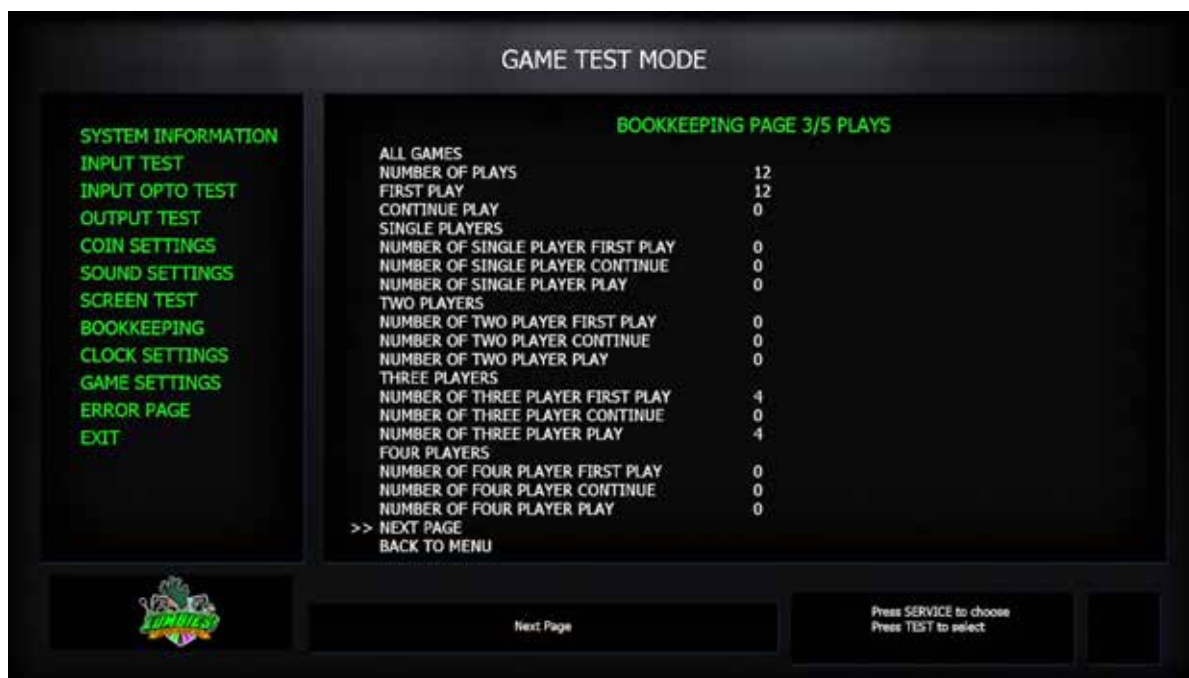

<b>All Games</b>	Sum total of all games played
<b>Single/Two/Three/Four Players</b>	Statistics for games with specified number of players
<b>Number of Plays</b>	Total number of games for all Players combined
<b>Continue Play</b>	Total number of continues into another game for all Players combined
<b>First Play</b>	Total number of first games for all Players combined
<b>No of 1/2/3/4 Player Plays</b>	Total number of plays from every Player combination
<b>No of 1/2/3/4 First Plays</b>	Total number of first plays from every Player combination
<b>No of 1/2/3/4 Continues</b>	Total number of continues from every Player combination
<b>Next Page</b>	Proceed to Bookkeeping Page 4
<b>Back</b>	Return to Main Test Menu

This menu details continues data and average play time.



<b>Total Continue Ratio</b>	Total percentage of continued games
<b>Total Continue SP Ratio</b>	Percentage of a single players continious games
<b>Total Continue 2P Ratio</b>	Percentage of two players continious games
<b>Total Continue 3P Ratio</b>	Percentage of three players continious games
<b>Total Continue 4P Ratio</b>	Percentage of four players continious games
<b>Total Time</b>	Total time of game has been on
<b>Play Time</b>	Total time of a continious play session
<b>Average Play Time</b>	Average percentage for race game time
<b>Next Page</b>	Proceed to Bookkeeping Page 5
<b>Back</b>	Return to Main Test Menu

This menu details the ticket payouts for each player and number of super bonuses won.

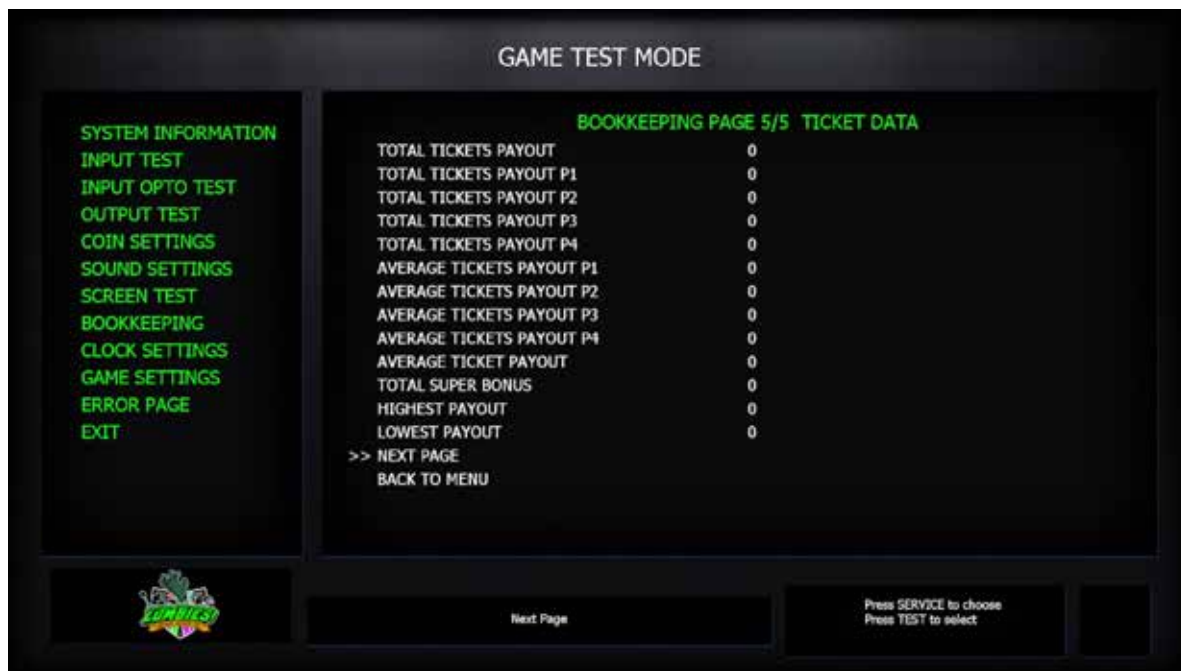

<b>Total Tickets Payout</b>	Total number of tickets paid out across all Players
<b>Total Tickets Payout P1-P4</b>	Total tickets paid out on each individual Player
<b>Average Tickets Payout P1-P4</b>	Average tickets paid out on each individual Player
<b>Average Tickets Payout</b>	Average number of tickets paid out across all Players
<b>Total Super Bonus</b>	Total number of super bonuses won
<b>Highest Payout</b>	The greatest amount of tickets paid out on one game
<b>Lowest Payout</b>	The fewest amount of tickets paid out on one game
<b>Next Page</b>	Return to Bookkeeping Page 1
<b>Back</b>	Return to Main Test Menu

## 9-11 CLOCK TEST

This menu allows you to set the internal Cabinet clock.



<b>Current Time</b>	Displays current time (24 Hour)
<b>Current Date</b>	Displays current Day/Month/Year
<b>Year</b>	Adjust Year
<b>Month</b>	Adjust Month
<b>Date</b>	Adjust Day
<b>Hour</b>	Adjust Hour (24 Hour)
<b>Minute</b>	Adjust Minute
<b>Second</b>	Adjust Second
<b>Back</b>	Return to Main Test Menu

## 9-12 GAME ASSIGNMENTS

This menu allows you to adjust gameplay variables like language, game timings, and difficulty.



**BOLD** = Default Value

<b>Game Difficulty</b>	Adjust Game difficulty (Very Easy-Easy-Normal-Hard-Very Hard) = <b>NORMAL</b>
<b>Max Tickets per Credit</b>	Set max ticket payout (5-250) = <b>30</b>
<b>Minimum Tickets</b>	Set amount of Minimum Tickets paid out (1-10) = <b>1</b> (Mercy Tickets are paid out if a Player scores 0 points)
<b>Super Bonus</b>	Set Super Bonus ticket payout amount (5-2000) = <b>500</b>
<b>Super Bonus Length</b>	Determines the amount of times the Super Bonus door opens (3-15 seconds) = <b>3 Times</b>
<b>Game Time</b>	Provides the option to determine the length of the games race time (30-120 seconds) = <b>90 seconds</b>
<b>Language</b>	Set the language for displayed text (English-Portuguese-Spanish-French-Italian) = <b>English</b>
<b>Kid Friendly Content</b>	Provides option to change game artwork for a mature audience (ON-OFF) = <b>ON</b>
<b>Freeplay Always Open</b>	<b>N/A</b>
<b>Introduction Videos</b>	Turns on/off the FMV scenes that play after a Player enters a Credit (ON-OFF) = <b>ON</b>
<b>Short Podium</b>	Shortens the post-game podium sequence by only focusing on the highest placed player (ON-OFF) = <b>OFF</b>
<b>Back to Menu</b>	Return to Main Test Menu



## 9-13 ERROR PAGE

This menu shows the error log and allows deactivation of player lanes.

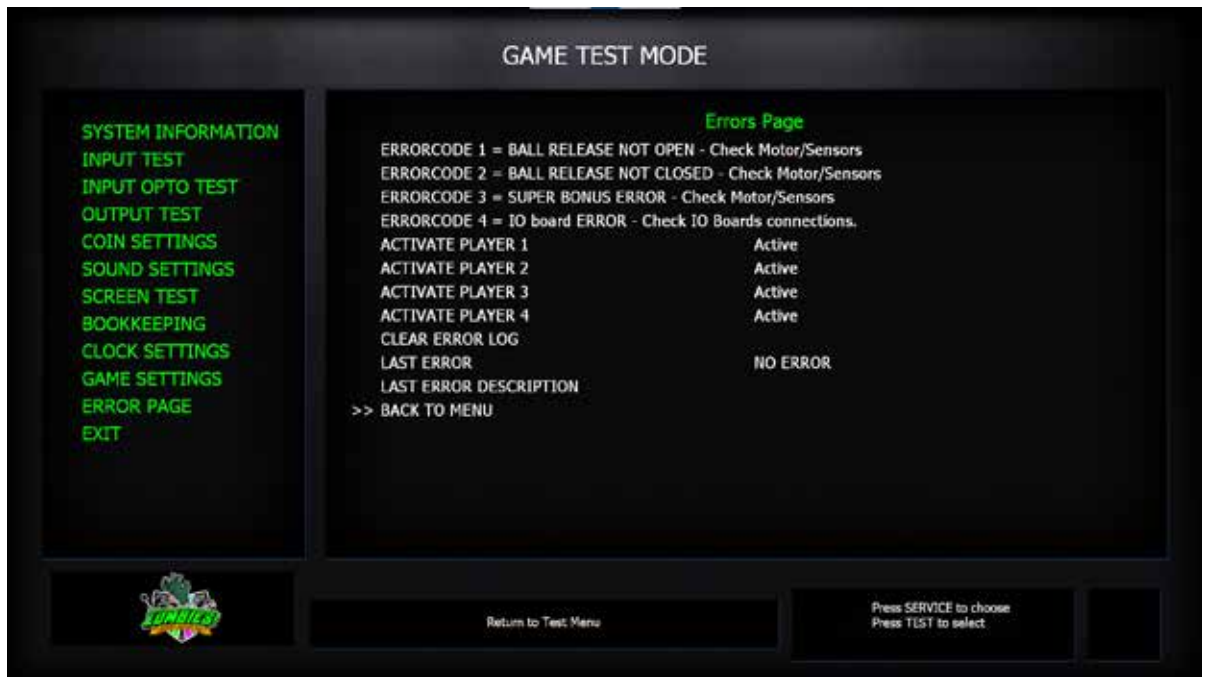

<b>Error Code 1</b>	Displays Error Code 1 and possible solution
<b>Error Code 2</b>	Displays Error Code 2 and possible solution
<b>Error Code 3</b>	Displays Error Code 3 and possible solution
<b>Error Code 4</b>	Displays Error Code 4 and possible solution
<b>Activate P1/2/3/4</b>	Shows Active Player Lanes - Lanes can be deactivated from this menu and will show "ERROR" to prevent customer plays
<b>Clear Error Log</b>	Clear current error and all previous errors
<b>Last Error</b>	The last recorded error
<b>Last Error Description</b>	Description of last recorded error and potential solution
<b>Back</b>	Return to Main Test Menu

## 10 VIDEO DISPLAY

### CAUTION

The LCD display screen is adjusted prior to leaving the factory.  
Avoid any unnecessary adjustment

### IMPORTANT

- If the adjustment method in this Manual does not resolve the problem, contact the customer service number in this Manual or your supplier
- Do not stick tape, stickers or anything else onto the screen. Any kind of adhesive may damage the surface of the screen

## 10-1 GENERAL DESCRIPTION

This specification applies to the **Colour LED 65" MTV65W-CV1RS**.



Item	Resolution	H Freq.(kHz)	V Freq.(Hz)	Note
1	640x480@60	31.469	59.940	VGA
2	800x600@56	35.156	56.250	SVGA
3	800x600@60	37.879	60.317	SVGA
4	1024x768@60	48.363	60.004	XGA
5	1280x720@60	44.770	59.860	720p-60
6	1280x768@60	47.600	60.030	WXGA
7	1360x768@60	47.539	59.573	LCD
8	1920x1080@60	67.158	59.96	Full HD

Model		MT55W-86723-A	
Mode Selection Guide		VGA+DVI+HDCP	
LCD Panel	Screen Size	54.6	
	Pixel Pitch(mm)	0.63*0.63	
	Backlight	LED	
	Response	8ms	
	Aspect Ratio	16:9	
Viewing Angle	Horizontal	178°	
	Vertical	178°	
Video	Input Mode	Full HD	
	Horizontal	31~67KHz	
	Vertical	59~60Hz	
Display	Resolution	1920*1080	
	Contrast Ratio	3500:1 Typ	
	Brightness	Min	280 cd/m2
		Typ	350 cd/m2
	Horizontal Size	1209.6mm	
	Vertical Size	680.4mm	
	Colors	16.7M	
	Bandwidth	74.25MHz Typ.	
Power	Consumption	105W Typ.± 20%	
	Management	VESA-DPMS	
		105W Typ.± 20%	
		PowerDown	
	Input	AC Power(Input 100-240VAC)	
Operations	Function Key	5Key	
	OSD Adjustment	Contrast, Brightness, Phase, Clock, H-position, V-position, ....Exit	
Input Signal		Analog:0.7vpp750hm&DVI-D Digital interface(TMDS)	
Signal Cable		Standard DVI cable/15-pin D-sub	
PC Interface		D-SUB15P/DVI	
EMI/Safety			
Operating Temperature		0°C~50°C	
Humidity		10~85%	
Outer Dimension(L*W*H)mm		1317.6x791.4x94.2	

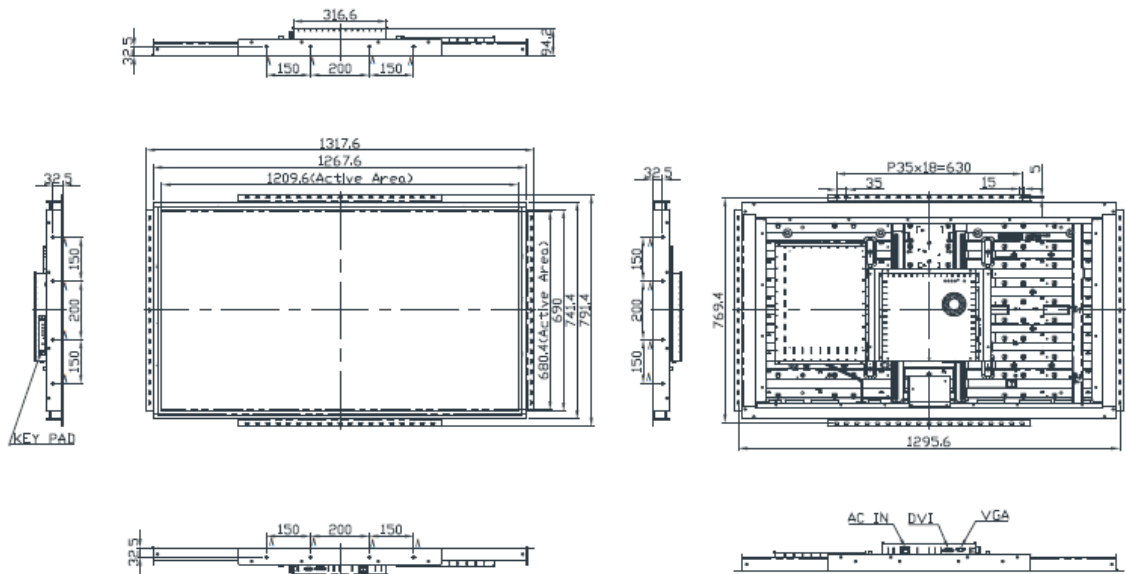

## 10-2 CLEANING THE SCREEN

### CAUTION

- Since the LCD display screen is susceptible to damage, pay careful attention to its handling. When cleaning, refrain from using water or volatile chemicals
- Do not climb onto the Control Panel(s). This could lead to injuries or damage to the Cabinet
- When reaching across the Control Panel(s) to clean the screen there is a risk of hurting your shoulder or arm. Use a mop with a non-feathery, soft, dry cloth mop head and wipe the surface of the screen

When the screen surface becomes dirty, clean it by using a soft cloth such as gauze. When water, and volatile chemicals such as benzene, thinner, etc., spill on the screen surface, it may be subject to damage. Therefore, do not use them.

Also, since the surfaces are susceptible to damage, refrain from rubbing them with a hard material or using a duster. If the screen is especially dirty, call in a professional cleaner.

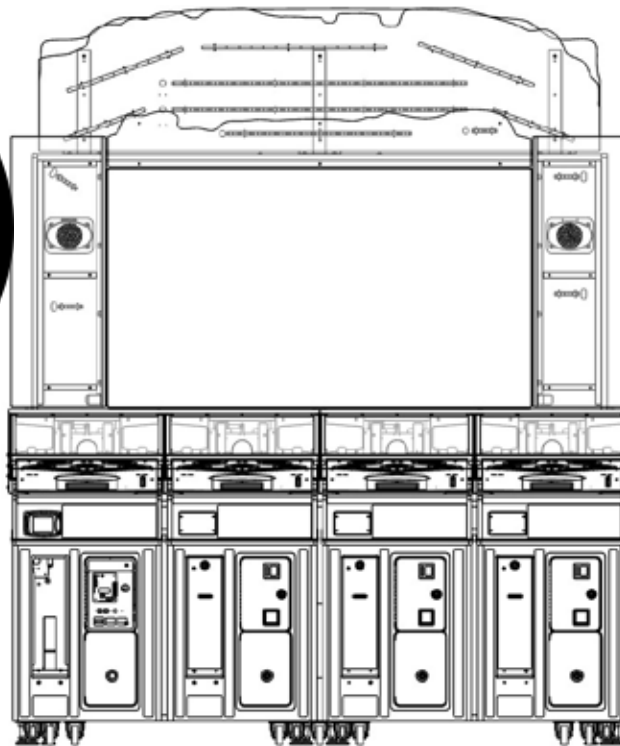

## 10-3 ON SCREEN ADJUSTMENT METHOD (OSD)

### **STOP** IMPORTANT!

- If the adjustment method in this Manual does not resolve the problem contact the customer service number in this Manual or your supplier
- Do not stick tape, stickers or anything else onto the screen. Any kind of adhesive may damage the surface of the screen
- The screen has been finely adjusted prior leaving the factory. Do not unnecessarily adjust the screen

#### OSD (On Screen Display)

The OSD offers the user various possibilities of customizing the appearance of the TFT display. By using the OSD Board, brightness, contrast, input selection, OSD appearance and much more can be adjusted easily.

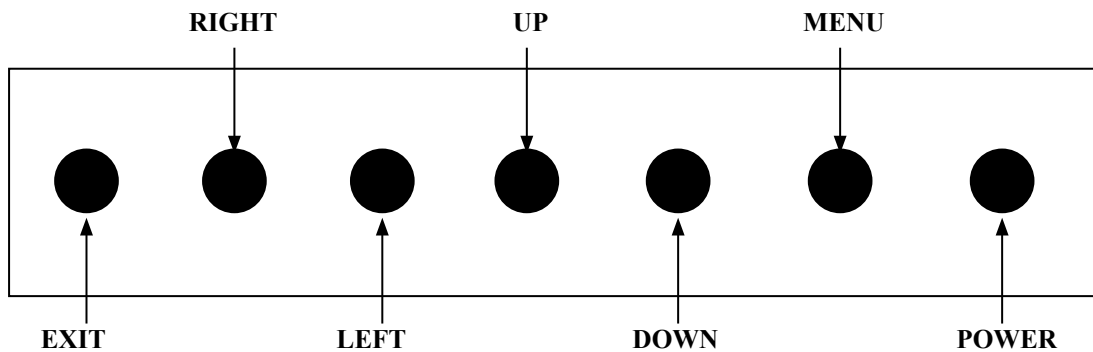

#### Operation and Buttons

ITEM	DESCRIPTION
Power	Turns Monitor On and Off
Right	Cycle option to the right
Left	Cycle option to the left
Menu	Open OSD Main Menu - Select option when in OSD Menu
Up	Cycle option up when in OSD Menu
Down	Cycle option down when in OSD Menu
Exit	Close OSD Main Menu - Cycle back to previous option Menu

## OSD Main Menu - Adjustments



The OSD Adjustment Main Menu is used for adjusting picture elements like Contrast and Brightness.

## OSD Main Menu - Feature Controls



The OSD Feature Control Main Menu is used for changing mechanical elements like the Input Channel and Timer.





ITEM	DESCRIPTION
Contrast	Adjusts the contrast level between different colours
Brightness	Adjusts overall brightness of picture
Sharpness	Adjusts edge to image contrast
Color Temperature	Adjust color temperature range
User RGB	Manually set levels of Red-Green-Blue display
Impact Alignment	N/A
Reset	Revert settings to Factory Default



Item	Description
Auto Color	N/A
Screen Test	N/A
Language	Changes language of OSD instructions
Input Source	Changes source of Monitor input (DVI/HDMI/VGA)
OSD Timer	Changes time OSD Menu displays before closing (in seconds)

## 10-4 MONITOR TROUBLESHOOTING

### Possible Fault States

#### Distorted Image with Noise/Flicker



#### Blank screen with Backlight ON





# IMPORTANT!

Before attempting this procedure, ensure power to the Cabinet is switched OFF

- 1 Remove the Upper Rear Doors of the Monitor Cabinet

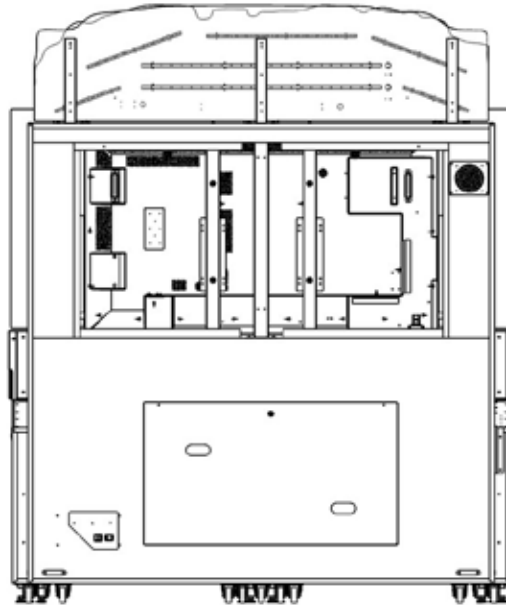

**⚠ CAUTION**  
The Monitor is HEAVY. Use at least 2 people when removing the Monitor

- 2 Remove the fixings securing the Monitor and remove the Monitor

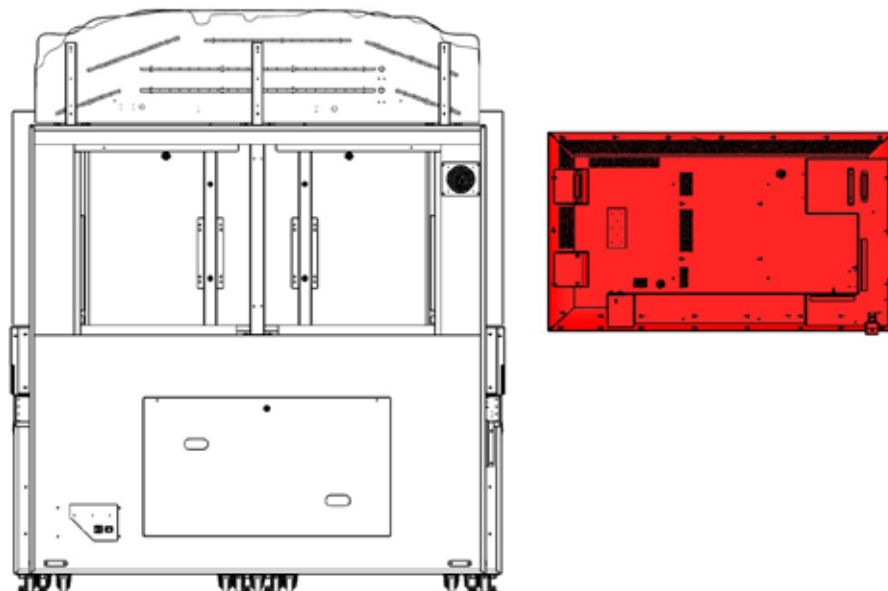

---

**3** Remove the fixings securing the Monitor Rear Cover and remove Cover

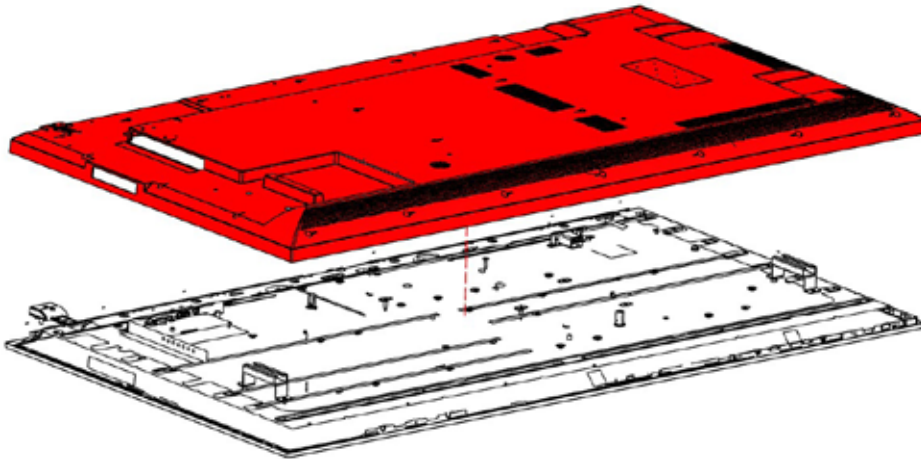

---

**4** Remove the Input Ribbon Cable

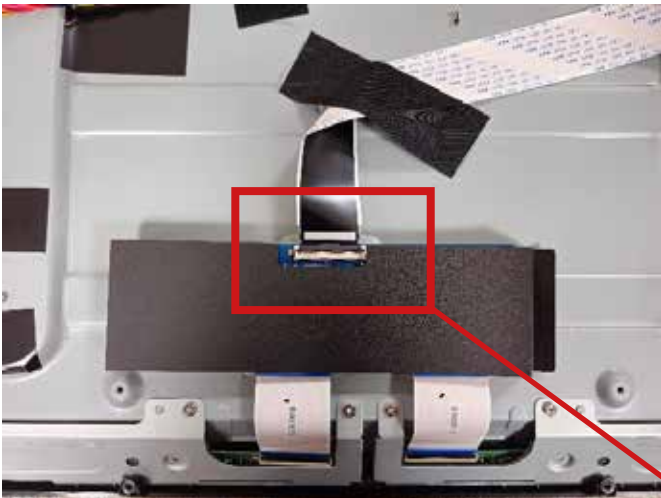

---

5 Remove Sticky Tape holding Ribbon Cable in position

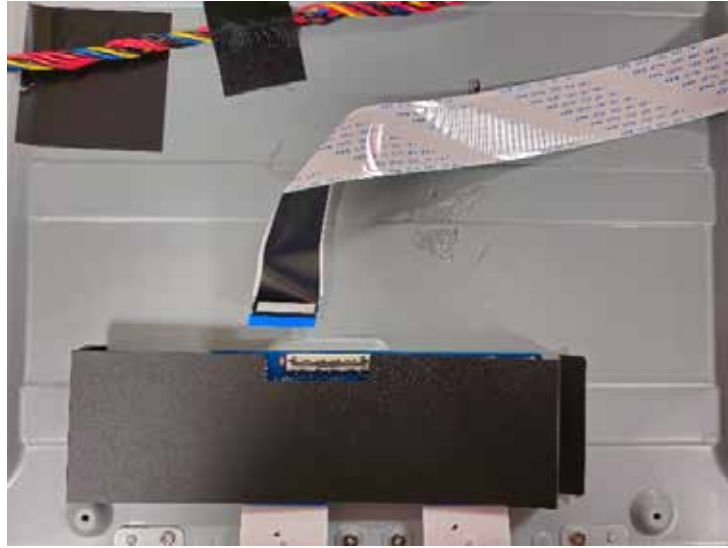

---

6 Reapply Ribbon Cable (ensure Ribbon Cable is secure and redressed)



---

7 Reapply tape in a secure fashion

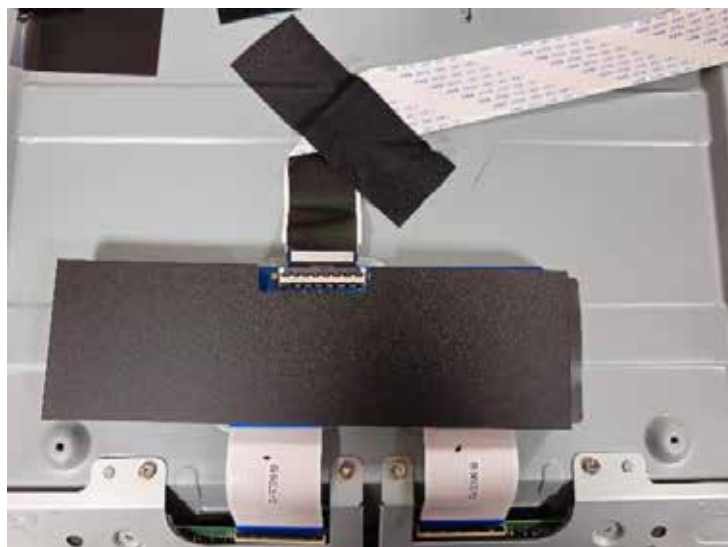

# 11 COIN HANDLING

## HANDLING THE COIN JAM

If the coin is not rejected when the REJECT button is pressed, open the coin chute door and open the selector gate. After removing the jammed coin, put a normal coin in and check to see that the selector correctly functions.

### 11-1 CLEANING THE COIN SELECTOR

#### STOP IMPORTANT

- Remove and clean smears by using a soft cloth dipped in water or diluted chemical detergent and then squeezed dry
- Never apply machine oil, etc. to the Coin Selector
- After cleaning the Coin Selector, insert a regular coin in the normal working status and ensure that the selector correctly functions

The Coin Selector should be cleaned once every 3 months.  
When cleaning, follow the procedure below:

- 1 Turn the power for the machine OFF. Open the Coin Chute Door
- 2 Remove the Coin Selector from the Coin Chute Door
- 3 Open the gate and dust off by using a soft brush (small soft Paint Brush, etc.)

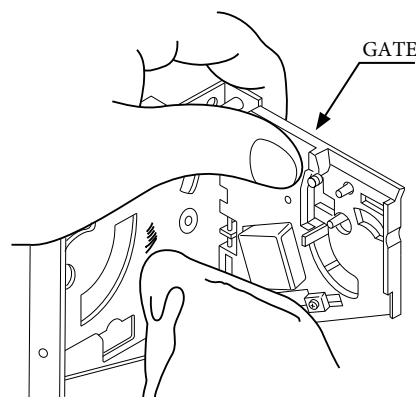

**CLEANING THE COIN SELECTOR (MECHANICAL)**

**1** Remove and clean smears by using a soft cloth dipped in water or diluted chemical detergent and then squeezed dry.

**2** Remove the CRADLE. When removing the retaining ring (E ring) be very careful so as not to bend the rotary shaft.

**3** Remove stain from the rotary shaft and shaft receiving portions by wiping off with a soft cloth, etc.

**4** After wiping off as per previous step, further apply a dry cloth to completely dry the Coin Selector.

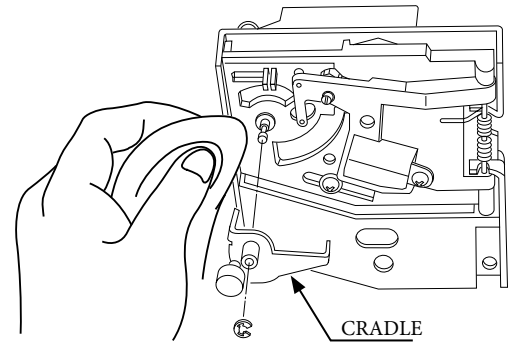

**Coin Insertion Test**

Once every month, when performing the Coin SW Test, simultaneously check the following:

Does the Coin Meter count satisfactorily?

Does the coin drop into the cashbox correctly?

Is the coin rejected when inserted while keeping the REJECT Button pressed down?

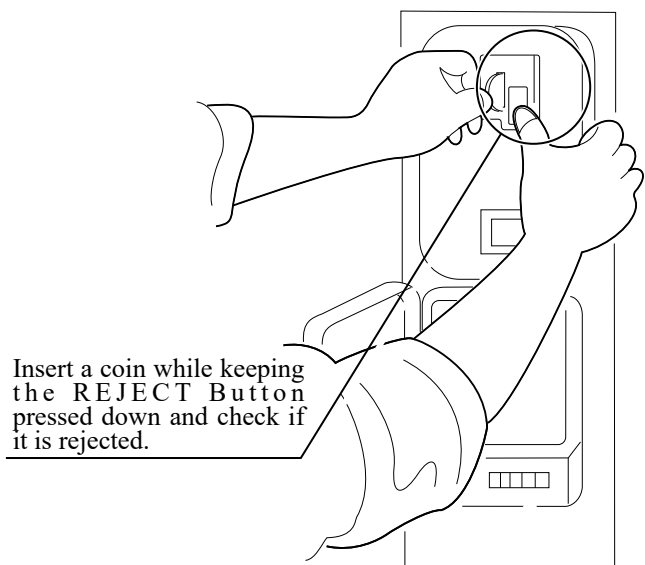



## CLEANING THE COIN SELECTOR (SR3 / NRI)

- 1 Remove and clean smears by using a damp soft cloth dipped in water. DO NOT use any diluted chemical detergent or cleansing agent as this will impair the workings of the component.

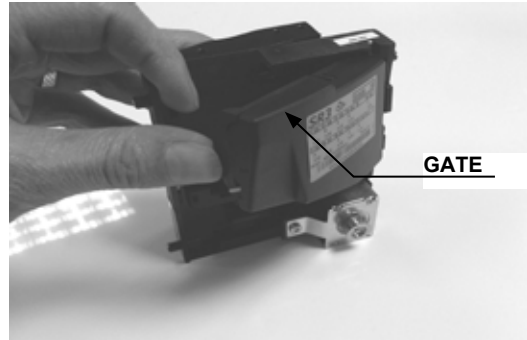

- 2 Open the reject gate to gain access to the rundown path.



- 3 Remove the dirt and stains from the runway by wiping off with a soft damp cloth.



- 4 After wiping off as per previous step, further apply a dry cloth to completely dry the coin Selector.

## 11-2 FAULT FINDING

### Fault Finding

The following information is presented for customers' guidance in rectifying a fault but does not cover all possible causes.

All acceptors with electronic faults should be returned to an approved service centre for repair.

SYMPTOM	INVESTIGATE	POSSIBLE CAUSE	
Acceptor does not work (all coins reject)	Connector	Poor Contact	
		Loose Wire	
	Power Supply		Not switched on
			Incorrect voltage
			Inadequate current
			Rise time too slow
	Inhibit all inputs	Acceptor Inhibited	
	Accept gate	Gate not free or dislocated	
	Accept channel	Obstruction	
	Reject gate	Not fully closed	
	LED on rear cover RED		EEPROM chksm error
			SR Sensor fault
			Credit opto fault
		Credit sensor blocked	
LED on rear cover YELLOW	Reject lever pressed		
	Reinstall power		
Poor Acceptance	Power Supply	Voltage less than 10v (Voltage drops when coil engages)	
	Accept gate	Gate jam or dislocated	
	Connector	Loose	
	Coin rundown	Dirty	
	Bank Select	Both banks enabled	
Coin stick or jam in acceptor	Accept channel	Acceptor dirty or may have some damage	
	Accept gate		
	Reject gate		
A true coin type rejects	Label	Coin not programmed	
No accept signal	Connector	Loose or broken wire	
	Accept channel	Path dirty or obstructed	

## 11-3 ADJUSTING THE PRICE OF PLAY (EXCEL)

### STOP IMPORTANT

The price of play is determined by the configuration of switches located on either the EXCEL or VTS board. The type of board used is determined by product location. Switch settings for both types of board remain the same

This product comes equipped with a Crane NRI Coin Acceptor. To adjust the price of play ALL CREDIT SETTINGS are adjusted via the EXCEL CREDIT BOARD.

#### IMPORTANT!

The CREDIT SETTINGS within the SYSTEM TEST MODE must be set to 1 Coin 1 Credit to allow the CREDIT BOARD to function correctly.

The CREDIT BD has a built in accumulator. This is controlled by 2 DIL Switches. These allow the operator to select the price of play, type of coin acceptor and region.

#### EXCEL Credit Board

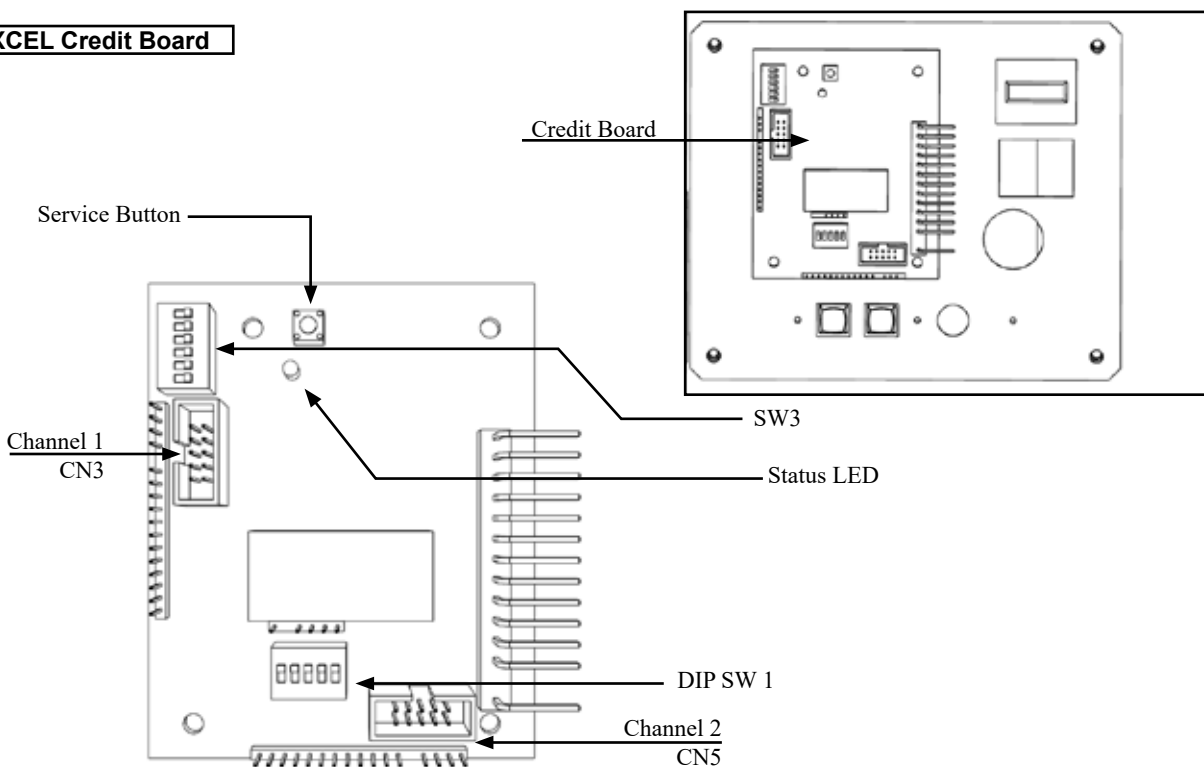

#### DIL SW3 (Regional Settings)

Adjust these switches to specify the type of Coin Acceptor used and currency.

Default = SW1&SW2 ON - SR3/NRI in parallel mode, Sterling.

#### SERVICE BUTTON

Provides a Service Credit when pressed

#### Status LED

Flashes when functioning

#### CHANNEL 1

To Coin Acceptor (SR3 TYPE)

#### DIL SW1 (credit settings)

Adjust to required price of pay

#### VOL CONTROL

Main Volume Adjustment (Front Speakers)

# 11-4 COIN REGION & PRICE OF PLAY SETTINGS

Country	Setting	Switch 3 Setting						Credit Board Mode Settings Switch 3											
		SW1	SW2	SW3	SW4	SW5	SW6	Coin Validator Programming						C120/SR3 Only					
							COIN1	COIN2	COIN3	COIN4	COIN5	COIN6	COIN7	COIN8	COIN9	COIN10	COIN11	COIN12	
UK	Coin Controls	OFF	OFF	OFF	OFF		£1	50p new	20p	10p	-	50p old	-	-					
	C220 Parallel	ON	OFF	OFF	OFF		£1	50p new	20p	10p	-	50p old	-	£2					
UK	Coin Controls	ON	OFF	OFF	OFF		£1	50p new	20p	10p	-	£2	-	50p old					
	C220 Binary	OFF	ON	OFF	OFF		£1	50p new	20p	10p	-	£2	-	50p old					
UK	Coin Controls	ON	ON	OFF	OFF		£1	50p new	20p	10p	-	£2	-	50p old					
	SR3 Parallel	OFF	OFF	ON	OFF		£2	£1	50p new	20p	10p	-	-	50p old					
Euro	SR3 Parallel	ON	OFF	ON	OFF		€2	€1	50¢	20¢	10¢	-	-	-					
UK	Mars MEMS	ON	OFF	ON	OFF		£1	£2	20p	10p	50p new	50p old							
	111 Parallel	OFF	ON	ON	OFF		10p	20p	50p	£1	£2	-							
UK	NRI Parallel	OFF	ON	ON	OFF														
Belgium	Parallel	ON	ON	ON	OFF		-	50Bfr	20Bfr	5Bfr									
Holland	Parallel	OFF	OFF	OFF	ON		-	5NLG	2.5NLG	1NLG									
Austria	SR3 Parallel	ON	OFF	OFF	ON		20Sch	10Sch	5Sch	1Sch									
Spain	Coin Controls	OFF	ON	OFF	ON		500Pta	200Pta	100Pta	50Pta	25Pta	200Pt old	50Pta old	25Pta old					
	C220 Binary	ON	ON	OFF	ON		500Pta	200Pta	100Pta	50Pta	25Pta	-	200Pta old	-					
Spain	SR3/NRI	ON	ON	OFF	ON														
	Parallel	OFF	OFF	ON	ON		100Pta	50Pta new	-	25Pta new	-	50Pta old	-	25Pta old					
Portugal	C220 Parallel	ON	OFF	ON	ON		200Es	100Es	50Es	-	-	-	-	-					
Euro	Parallel	ON	OFF	ON	ON		€1	50¢	50Es	-	-	-	-	-					
	TBA				OFF		TBA												
	Channels					ON	TBA												
						OFF	Direct Mode												
						ON	2 channel Mode												

Note: These switch settings are under constant review and may change due to world currency updates.

Set SW 1 according to the option settings found in the relevant Price of Play Settings Table on the following pages.

Set SW 3 on the VTS /Excel board as shown in the table above corresponding to the country required.

**Please Note**  
The credit board automatically sets the validator for parallel and binary operation through an output on pin 8 of the 17 way pinstrip. For the feature to work it is necessary for the validator interconnecting cable to include at wire at this position

	PRICE OF PLAY	BONUS	DIL SWITCH 1				
			1	2	3	4	5
<b>1</b>	<b>0.10</b>	-	<b>OFF</b>	<b>OFF</b>	<b>OFF</b>	<b>OFF</b>	<b>OFF</b>
2	0.10	0.50 = 6 credits	ON	OFF	OFF	OFF	OFF
<b>3</b>	<b>0.20</b>	-	<b>OFF</b>	<b>ON</b>	<b>OFF</b>	<b>OFF</b>	<b>OFF</b>
4	0.20	0.50 = 3 credits	ON	ON	OFF	OFF	OFF
<b>5</b>	<b>0.30</b>	-	<b>OFF</b>	<b>OFF</b>	<b>ON</b>	<b>OFF</b>	<b>OFF</b>
6	0.30	1.00 = 4 credits	ON	OFF	ON	OFF	OFF
7	0.30	0.50 = 2 credits	OFF	ON	ON	OFF	OFF
8	0.30	1.00 = 3 credits	ON	ON	ON	OFF	OFF
<b>9</b>	<b>0.40</b>	-	<b>OFF</b>	<b>OFF</b>	<b>OFF</b>	<b>ON</b>	<b>OFF</b>
10	0.40	1.00 = 3 credits	ON	OFF	OFF	ON	OFF
<b>11</b>	<b>0.50</b>	-	<b>OFF</b>	<b>ON</b>	<b>OFF</b>	<b>ON</b>	<b>OFF</b>
12	0.50	1.00 = 3 credits	ON	ON	OFF	ON	OFF
13	0.50	2.00 = 5 credits	OFF	OFF	ON	ON	OFF
<b>14</b>	<b>0.60</b>	-	<b>ON</b>	<b>OFF</b>	<b>ON</b>	<b>ON</b>	<b>OFF</b>
15	0.60	1.00 = 2 credits	OFF	ON	ON	ON	OFF
<b>16</b>	<b>0.80</b>	-	<b>ON</b>	<b>ON</b>	<b>ON</b>	<b>ON</b>	<b>OFF</b>
17	0.80	1.50 = 2 credits	OFF	OFF	OFF	OFF	ON
<b>18</b>	<b>1.00</b>	-	<b>ON</b>	<b>OFF</b>	<b>OFF</b>	<b>OFF</b>	<b>ON</b>
19	1.00	2.00 = 3 credits	OFF	ON	OFF	OFF	ON
20	1.00	4.00 = 5 credits	ON	ON	OFF	OFF	ON
<b>21</b>	<b>1.50</b>	-	<b>OFF</b>	<b>OFF</b>	<b>ON</b>	<b>OFF</b>	<b>ON</b>
22	1.50	2.00 = 2 credits	ON	OFF	ON	OFF	ON
<b>23</b>	<b>2.00</b>	-	<b>OFF</b>	<b>ON</b>	<b>ON</b>	<b>OFF</b>	<b>ON</b>
24	2.00	5.00 = 3 credits	ON	ON	ON	OFF	ON
<b>25</b>	<b>3.00</b>	-	<b>OFF</b>	<b>OFF</b>	<b>OFF</b>	<b>ON</b>	<b>ON</b>
26	3.00	5.00 = 2 credits	ON	OFF	OFF	ON	ON
<b>27</b>	<b>5.00</b>	-	<b>OFF</b>	<b>ON</b>	<b>OFF</b>	<b>ON</b>	<b>ON</b>
28	5.00	10.00 = 3 credits	ON	ON	OFF	ON	ON
<b>29</b>	<b>7.50</b>	-	<b>OFF</b>	<b>OFF</b>	<b>ON</b>	<b>ON</b>	<b>ON</b>
30	7.55	10.00 = 2 credits	ON	OFF	ON	ON	ON
<b>31</b>	<b>10.00</b>	-	<b>OFF</b>	<b>ON</b>	<b>ON</b>	<b>ON</b>	<b>ON</b>
32		FREE PLAY	ON	ON	ON	ON	ON

The price of play is controlled by DIL switches 1 to 5 of a bank of 8, located on the EXCEL CREDIT BD.

Default values are in **BOLD**

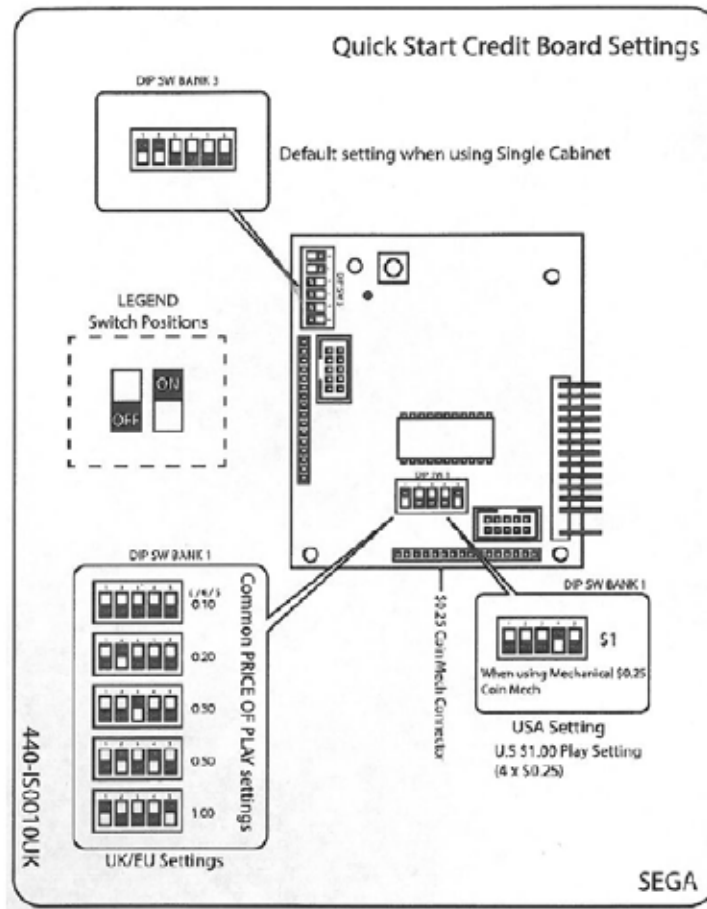

DIL SWITCH BANK ONE (5 way SW1)						
Item	Price	SW1	SW2	SW3	SW4	SW5
1	25cent	OFF	OFF	OFF	OFF	OFF
3	50cent	OFF	ON	OFF	OFF	OFF
5	75cent	OFF	OFF	ON	OFF	OFF
9	\$1.00	OFF	OFF	OFF	ON	OFF
16	\$2.00	ON	ON	ON	ON	OFF
DIL SWITCH BANK TWO (6 way SW3)						
Type	SW1	SW2	SW3	SW4	SW5	SW6
USA	OFF	OFF	OFF	OFF	OFF	OFF

## 12 LAMPS AND LIGHTING

### ⚠ WARNING

- When working with the product, be sure to turn the power off. Working with the power on may cause an electric shock or short circuit
- You may get burned by a hot fluorescent lamp or other lamps. Pay full attention to the lamps when performing the work
- Be sure to use lamps of the designated rating. Using lamps of undesignated rating can cause a fire or malfunctioning
- There is the danger of short circuits or smoke generation due to deterioration of insulation in lighting fixtures resulting from age deterioration. Check for anomalies such as the following: Does it smell like something is burning? Is there socket discoloration? Are any lamps being replaced frequently? Do lamps not power on properly?

### ⚠ CAUTION

The Coin Door Lamp utilises a 12v 1.2w Wedge Bulb. It is important that you replace this bulb or any other bulb of that of the same voltage and rating. Failing to observe this caution may result in PCB failure or possible fire hazard

### 12-1 COIN DOOR LAMP

Step 1. Open the Coin Door and locate the Lamp Housing directly behind the Coin Insert Bezel

Step 2. Hold the Lamp Housing firmly between your index finger and thumb and gently pull upwards. Do not try to remove the Lamp Housing whilst holding the bulb as the bulb may break causing injury

Step 3. Once the Lamp Housing has been removed, carefully hold the bulb between your fingers and pull the Lamp Housing away

Do not twist either bulb or Lamp Housing while removing the bulb as this may cause damage to both bulb and/or Housing.

Step 4. Simply push-fit a replacement bulb of the same type and follow these steps in reverse to refit

Lamp Housing

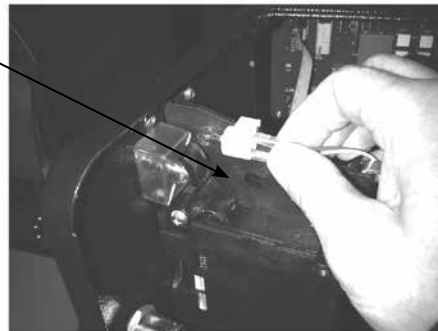

Type: Wedge Bulb - 12v, 1.2w



## 12-2 CABINET LED LIST

Related Assembly	Lighting Part # + Description	QTY
ZR-1000XUK ASSY CONTROL CAB	EP1421 LED 12V RED RS 541-4072	2
	SAI-6108-0500UK WH ASSY LED 500MM	2
	SAI-6108-0360UK WH ASSY LED 360MM	2
ZR-2040X-01UK ASSY BALL SENSOR	838-0066UK RGB IR RING	1
ZR-2060UK ASSY PLAYDECK LOWER ILLUMINATION	SAI-6503-0120UK WH ASSY LED 120MM	7
ZR-2100XUK ASSY PLAYDECK DIVIDER INNER	SAI-6108-1400UK WH ASSY LED 1400MM	1
ZR-2105XUK/ ZR-2110XUK ASSY PLAYDECK DIVIDER LH/RH	SAI-6108-1400UK WH ASSY LED 1400MM	1
ZR-2150XUK ASSY SUPER BONUS	SAI-6108-0420UK WH ASSY LED 420MM	2
	SAI-6509-0150UK WH ASSY LED 150MM	1
ZR-5000XUK ASSY BILLBOARD	SAI-6108-0250UK WH ASSY LED 250MM	2
	SAI-6504-0600UK WH ASSY LED 600MM	1
	SAI-6504-1000UK WH ASSY LED 1000MM	2
	SAI-6503-0080UK WH ASSY LED 80MM	1
	SAI-6108-0350UK WH ASSY LED 350MM	1
	SAI-6108-0300UK WH ASSY LED 300MM	1
	SAI-6108-0550UK WH ASSY LED 550MM	1

## 12-3 CABINET LED LOCATIONS

ZR-1000XUK

1 - SAI-6108-0500UK

2 - SAI-6108-0360UK

3 - EP1421

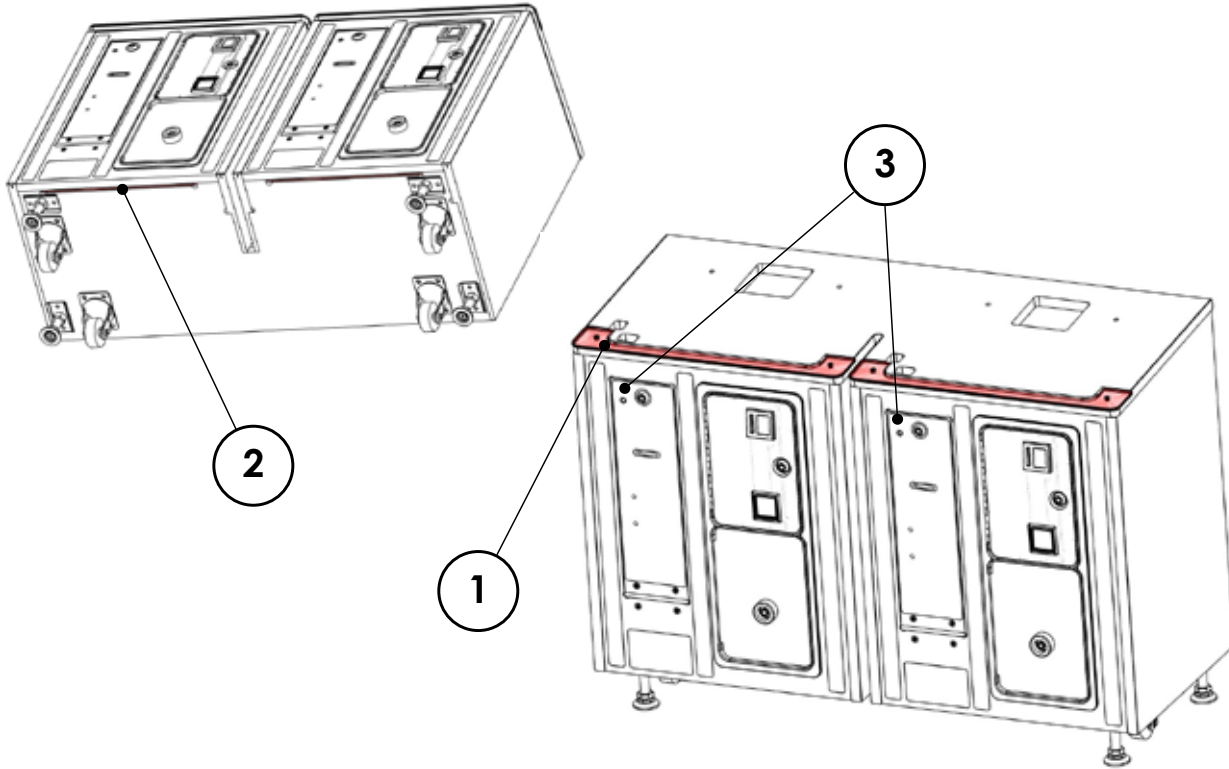

ZR-2040X-01UK

1 - 838-0066UK

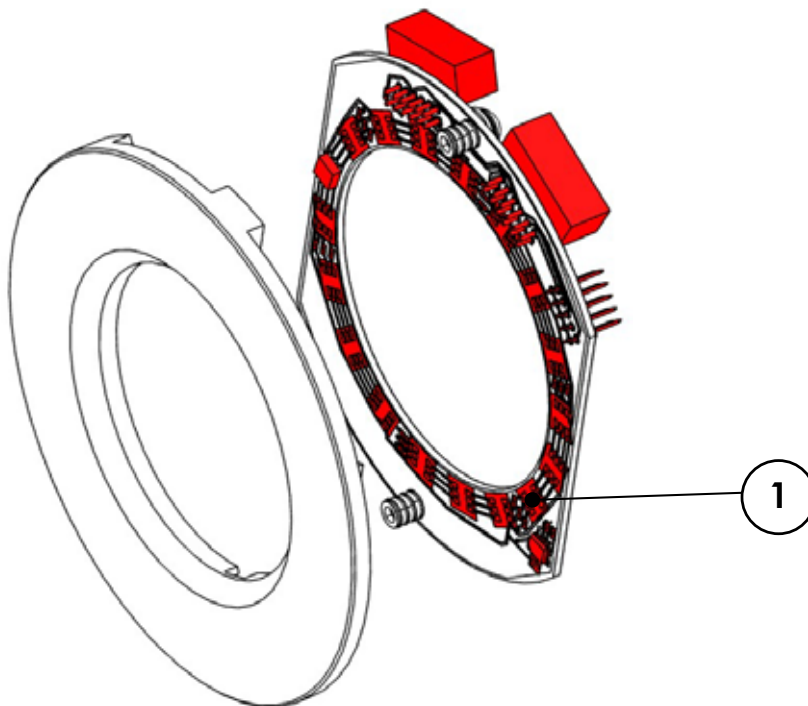

ZR-2060UK

1 - SAI-6503-0120UK

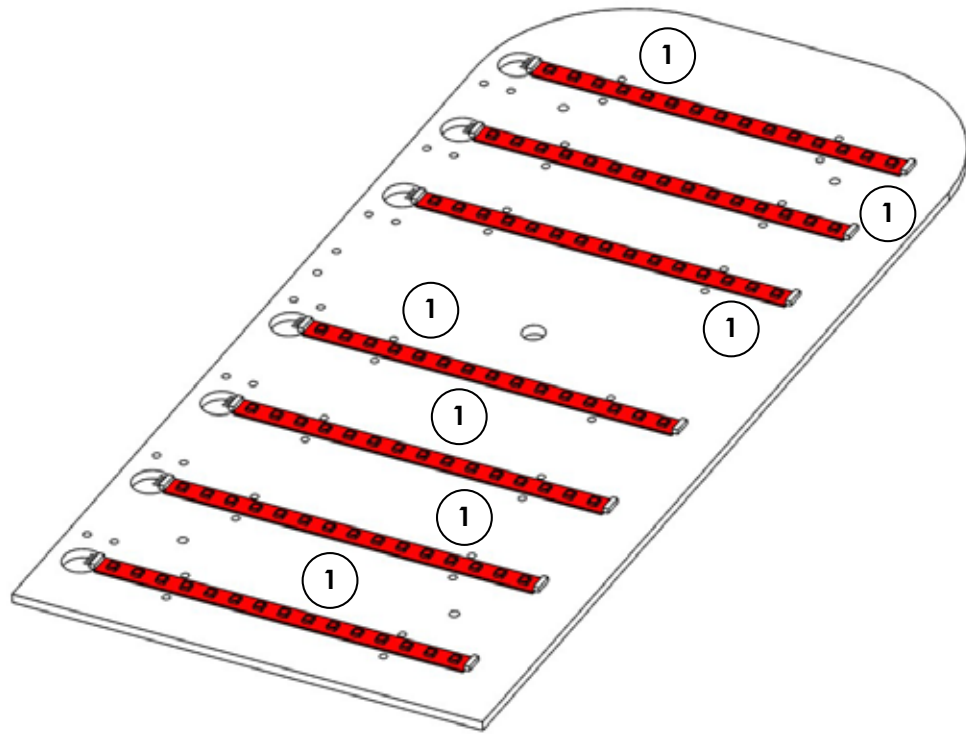

ZR-2100XUK

1 - SAI-6108-1400UK

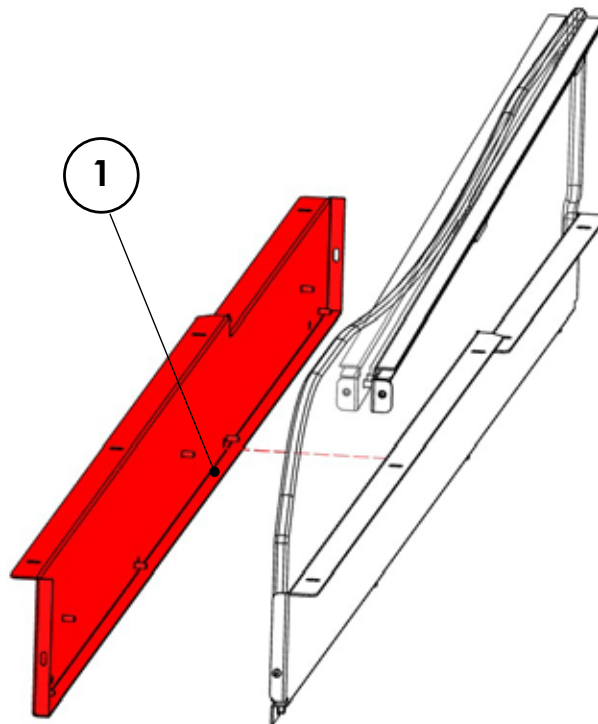

ZR-2105XUK/2110XUK  
1 - SAI-6108-1400UK

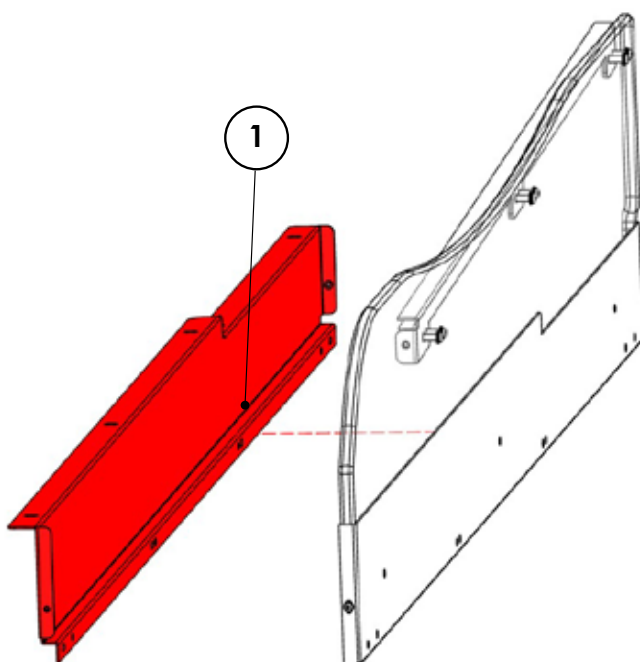
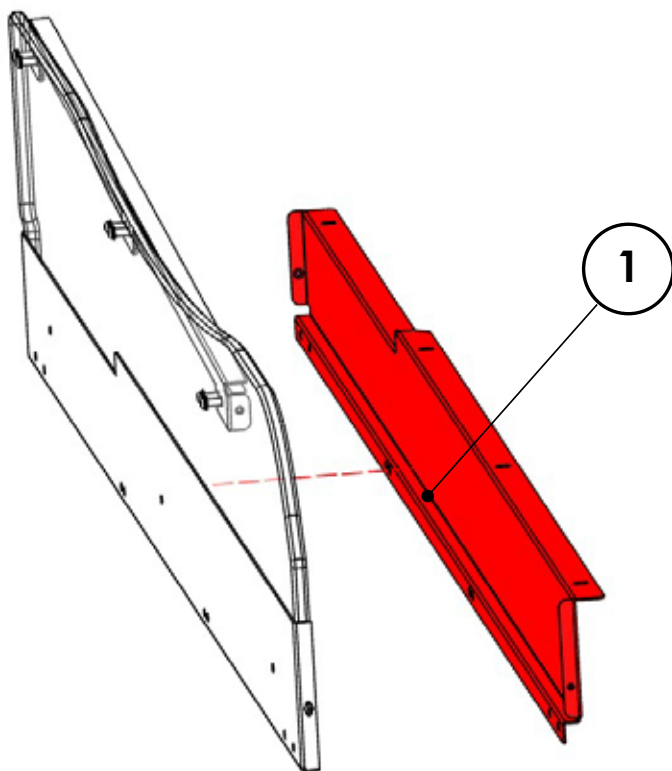

ZR-2150XUK

1 - SAI-6108-0420UK

2 - SAI-6509-0150UK

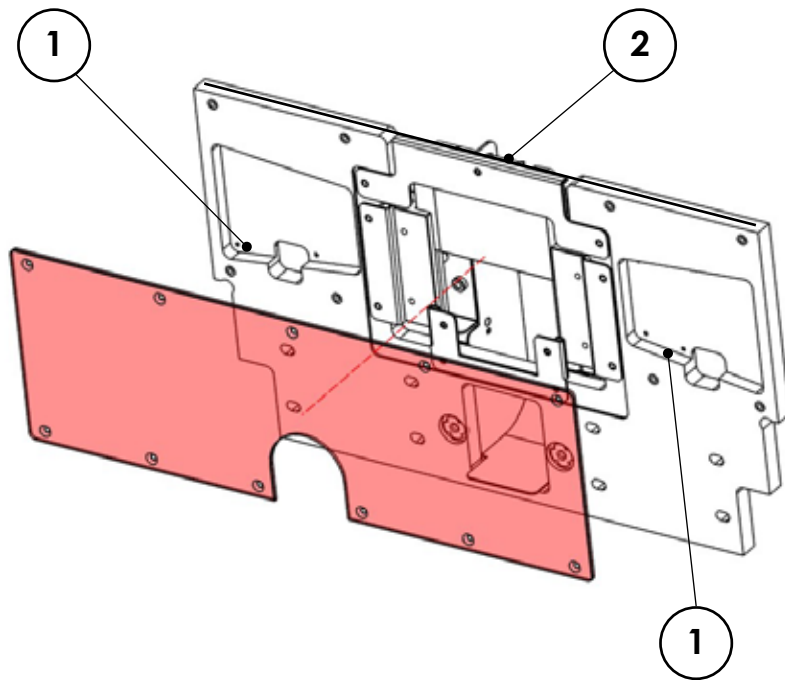

ZR-5000XUK

1 - SAI-6108-0250UK

2 - SAI-6504-1000UK

3 - SAI-6504-0600UK

4 - SAI-6503-0080UK

5 - SAI-6108-0350UK

6 - SAI-6108-0550UK

7 - SAI-6108-0300UK

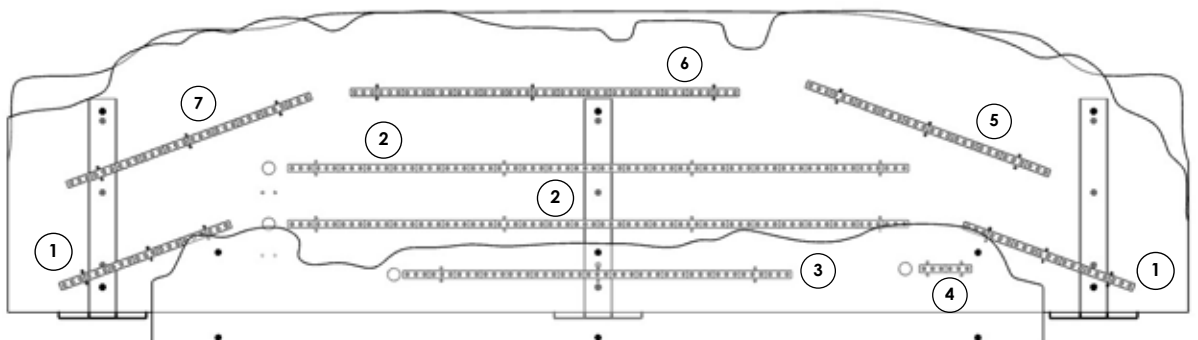

# 13 PERIODIC INSPECTION

The items listed below require periodic check and maintenance to retain the performance of this machine and to ensure safe business operation.

When handling the controller, the player will be in direct contact with it. In order to always allow the player to enjoy the game, be sure to clean it regularly.

## WARNING

- Every 6 months check to see if power cords are damaged, the plug is securely inserted, no dust has accumulated between the socket outlet and the power plug, etc. Using the product with accumulated dust in the interior may cause fire or electric shock
- Never use a water jet, etc. to clean the inside or outside of the Cabinet. If wetness occurs for any reason, do not use the product until it has completely dried
- Once a year, request the office shown on this Manual or the dealer from whom the product was originally purchased to perform the internal cleaning. Using the product with accumulated dust in the interior may cause fire or other accidents
- Note that you are liable for the cost of cleaning the interior parts
- There is the danger of accidents involving electrical shorts circuits or fire caused by factors such as the deterioration of insulation in electrical and electronic equipment over time. Check that there are no abnormalities such as odours from burning

PERIODIC INSPECTION TABLE

PERIOD	ITEM	DESCRIPTION	REFERENCE
As appropriate	Cabinet Surface	Cleaning	As Below
	Control Unit Surface		
Daily	Cabinet	Confirm Adjusters Contact Floor	Chapter 6
	Playdeck	No Ball(s) are obstructed	Chapter 14
Monthly	Cabinet	Speaker Volume	
	LEDs	LED Inspection	Chapter 12
	Coin Selector	Coin Path Inspection	Chapter 11
		Coin Insertion Test	Chapter 11
Every 3 Months	Coin Selector	Cleaning	Chapter 11
1 Year	Game BD	Cleaning	Chapter 15
	Power Cables	Inspection / Cleaning	Chapter 6
	Cabinet Interior	Cleaning	As Below

**Cleaning the Cabinet Surfaces**

When the Cabinet surfaces are badly soiled, remove stains with a soft cloth dipped in water or diluted (with water) chemical detergent and squeezed dry. To avoid damaging surface finish, do not use solvents such as thinner, benzine, etc. other than ethyl alcohol, or abrasives, bleaching agent and chemical dustcloth.

Some general-purpose household, kitchen and furniture cleaning products may contain strong solvents that degrade plastic components, coatings, and print. Before using any cleaning product, read the product's cautionary notes carefully and test the product first on a small area that is not highly visible.

**DISPLAY (LCD SCREEN Cleaning)**

When the Display LCD Screen surfaces are dirty, smudges or greasy, gently wipe the display with a dry, lint-free, soft cloth. If you see a scratch-like mark on your display, it might be a stain which has been transferred from food like matter when the screen was depressed from the outside. To avoid damaging surface finish, do not use such solvents as thinner, benzine, etc. the same applies to ethyl alcohol, or abrasives, bleaching agent and chemical dustcloths.

Wipe or dust the stain gently with a dry, soft cloth. If the stain remains, moisten a lint-free, soft cloth with water or a 50-50 mixture of isopropyl alcohol and water that does not contain impurities. Wring out as much of the liquid as possible and wipe the display again; do not let any liquid drip from the cloth.

Antistatic and purpose made LCD cleaning wipes are also acceptable alternatives.





## 14 TROUBLESHOOTING

### 14-1 TROUBLESHOOTING (WHEN NO ERROR MESSAGE IS SHOWN)

#### WARNING

- This work should be performed by site maintenance personnel or other skilled professionals. Work performed by non-technical personnel can cause a severe accident such as an electric shock. If there are no site maintenance personnel or other skilled professionals available, turn off the power immediately and contact the office given in this Manual or from point of purchase
- When working with the product, be sure to turn the power off. Working with the power on may cause an electric shock or short circuit accident
- In order to prevent electric shock and short circuit, be sure to turn power off before performing work
- Be careful so as not to damage wirings. Damaged wiring can cause electric shock or short circuit
- After removing the cause of the functioning of the Circuit Protector, reinstate the Circuit Protector. Depending on the cause of the functioning, using the Circuit Protector as is without removing the cause can cause generation of heat and fire hazard
- In the event that a problem cannot be resolved by employing the procedures listed in this Manual, be sure to request service from the office shown in this Manual or the dealer from whom the product was originally purchased. Attempts to employ procedures other than those specified in this Manual can cause electrical shock, shorting, or fire
- In the event of a problem that is not described here, be sure to contact the office shown on this Manual or the dealer from whom the product was originally purchased. Careless attempts at repair can result in electrical shock, shorting, or fire

STOP

#### IMPORTANT

- If an error message is displayed, identify the cause and without delay take the appropriate countermeasures. Leaving the error unaddressed could result in a breakdown
- If a problem occurs, first inspect the connection of any wiring connectors
- Static electricity from your body may damage some electronic devices on the IC board. Before handling any IC board, touch a grounded metallic surface so that static electricity is discharged

If a problem occurs, first check to make sure that the wiring connectors are properly connected.

## GENERAL

PROBLEM	POTENTIAL CAUSE	COUNTERMEASURE
With Main Switch ON there is no activation	Power is not supplied	Fully insert power lead into outlet
	Supply voltage is not correct	Adjust supply voltage to correct value
	Game Board is not receiving power	Check power connectors to Game Board
	Fuse has blown	Replace fuse
No Sound	Volume not properly adjusted	Adjust volume
	Poor connection of connectors	Check connections of amp
	Board, amp, or speaker fault	Run speaker test to check
Monitor is not displaying picture	Poor connection to Monitor	Check connection to Monitor (Chapter 10)
Monitor has Backlight but no picture	Poor Monitor Ribbon Cable to T-Con Board connection	Check Ribbon Cable connection to Monitor (Chapter 10)
Monitor has flickering picture/ noise distortion	Poor Monitor Ribbon Cable to T-Con Board connection	Check Ribbon Cable connection to Monitor (Chapter 10)
Switch and/or Volume Pot input does not work	Poor connection of connectors	Check the connection to Game Board
Tickets are not being vended	Tickets have been depleted	Replenish tickets
	Obstruction to Ticket Vend	Remove obstruction

## GAME SPECIFIC

PROBLEM	CAUSE	COUNTERMEASURE
Super Bonus Door not opening	Motor error	Check Voltage to Motor
		Check I/O Board for affected Player
		Check Motor Harness is connected properly/fully
	Door jammed	Remove obstruction(s)
		Reset Door (lift by hand with power off or while Game is in Test Mode)
		Perform Super Bonus Reveal Test in Test Menu (Output Test) to reset
Balls not returned to Player	Balls transferred from one Player Lane to another	Check Ball quantity on each Player Lane and redistribute
	Ball Release jam	Clear obstruction
	Ball Release Motor error	Perform Ball Release Test in Test Mode (Output Test) to reset

## SOFTWARE ERROR CODES

ERROR CODE #	ERROR CODE DESCRIPTION	COUNTERMEASURE
ERROR CODE 1	Ball Release Not Open	Perform <b>Ball Release Test</b> in Test Mode (Output Test) to reset
ERROR CODE 2	Ball Release Not Closed	Perform <b>Ball Release Test</b> in Test Mode (Output Test) to reset
ERROR CODE 3	Super Bonus Error	Perform <b>Super Bonus Reveal Test</b> in Test Menu (Output Test) to reset
ERROR CODE 4	I/O Error	Check I/O Board wiring connections ( <b>perform power cycle after reconnections</b> )

### Note:

The table above shows a list of possible failures and a brief solutions. If problems persist further or there are additional issues which may not be listed here. Please contact your point of sale or the SEGA Service Department on the contact numbers shown at the end of this Manual.

## 15 GAME BOARD

### WARNING

- When working with the product, be sure to turn the power off. Working with the power on may cause an electric shock or short circuit
- Be careful not to damage the wires. Damaged wires may cause electric shock, short circuit or present a fire risk
- Do not expose the Game Board, etc. without good reason. Failure to observe this can cause electric shock hazard or malfunctioning
- Do not use this product with connectors other than those that were connected and used with the Game Board at the time of shipping. Do not carelessly connect wires to connectors that were not used at the time of shipping as this may cause overheating, smoke, or fire damage
- When returning the Game Board after making repairs or replacements, make sure that there are no errors in the connection of connectors. Erroneous connections can lead to electrical shock, short circuits or fires
- When connecting a connector, check the direction carefully. Connectors must be connected in only one direction. If indiscriminate loads are applied in making connections, the connector or its terminal fixtures could be damaged, resulting in electrical shock, short circuits, or fires

### CAUTION

- In this product, setting changes are made during the Test Mode. The Game Board need not be operated. Use the Game Board, etc. as is with the same setting made at the time of shipment so as not to cause electric shock and malfunctioning
- Static electricity from your body may damage some electronics devices on the IC board. Before handling the IC board, touch a grounded metallic surface so that the static electricity can be discharged

## IMPORTANT!

- When a Game Board is to be replaced, put the old Game Board with anomaly into a special box for replacing the Game Board. If a special box is not available or if it has been damaged, arrange to have the Game Board packed in suitable packaging
- For replacement or repair, pack the Game Board and send it without disassembling it. Order for servicing may not be accepted if any part of the Game Board has been removed. If any part is removed, a service fee will be charged even if the warranty period has not yet expired
- Do not remove the Key Chip from the Game Board before sending the board for servicing

## 16-1 HOW TO REMOVE GAME BOARD

- 1 Turn off the power
- 2 On the Door Rear Lower, unlock using Master Key and remove the (2) M4 fixings to remove the door

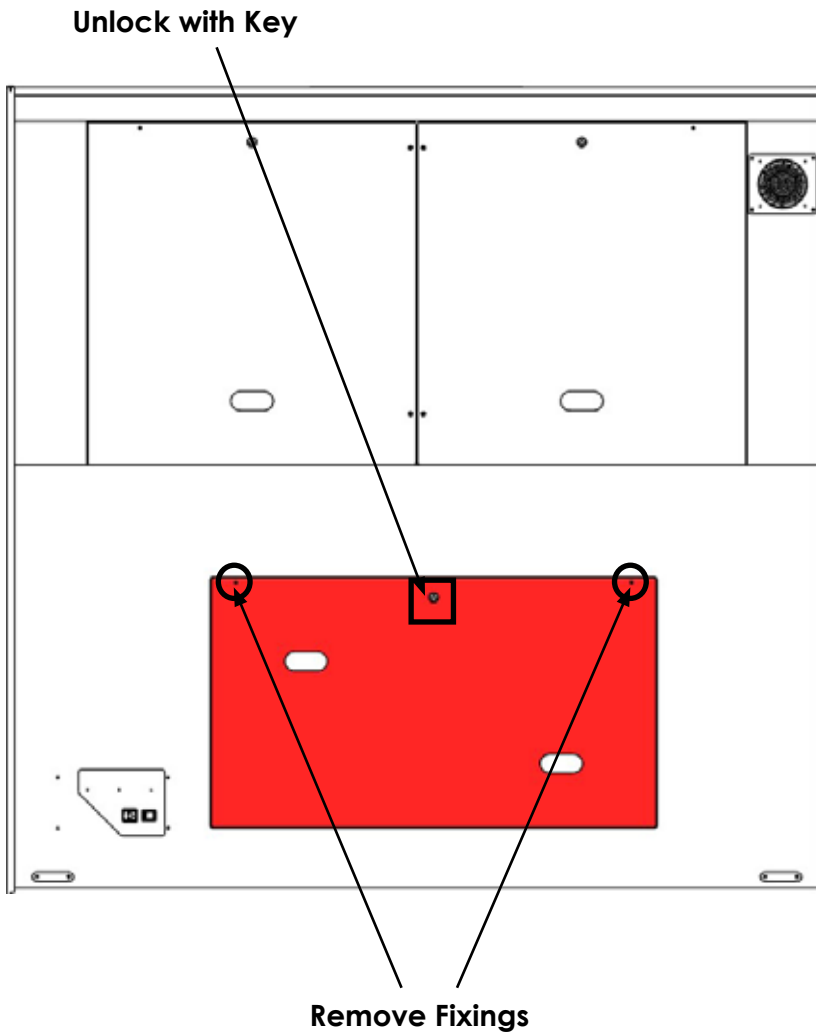

3 The Game Board is located here. Remove the (2) M4 fixings from the Base Game Board

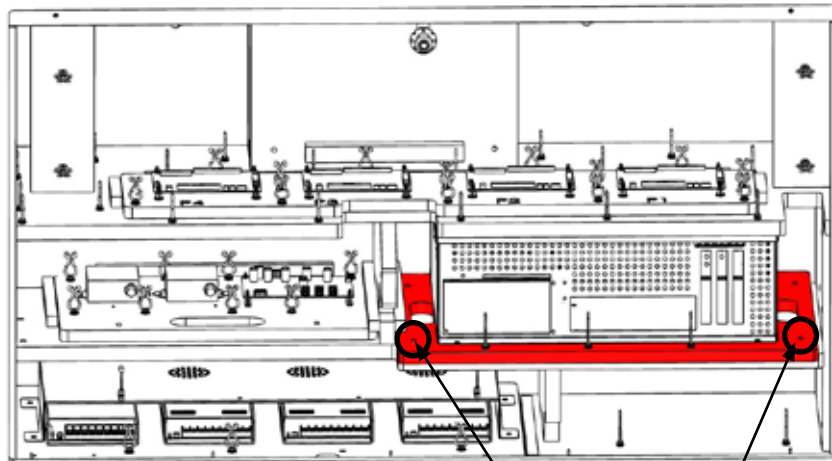
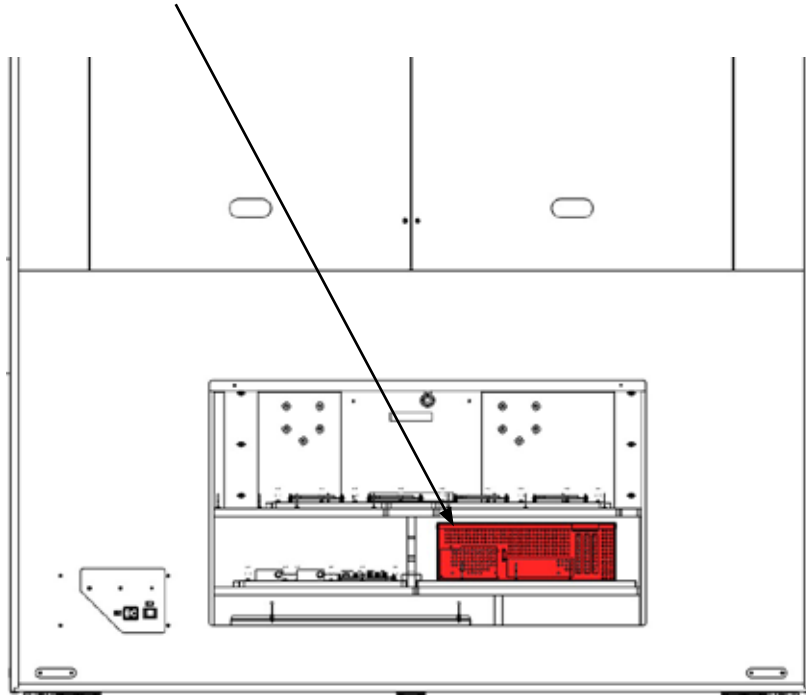

Remove Fixings

4 Disconnect all of the connectors connected to the Game Board

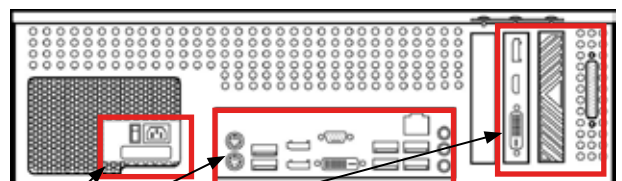

Carefully disconnect any and all connections to/ from the Game Board

5 Lift and remove the Game Board from the Cabinet. **The Game Board is HEAVY** so take care not to clash with other components when removing as this could cause component damage

# 16 DESIGN RELATED PARTS

For the warning display stickers, refer to Section 1.





# 17 PARTS LIST

## ZOMBIES RDG STRUCTURE FLOW

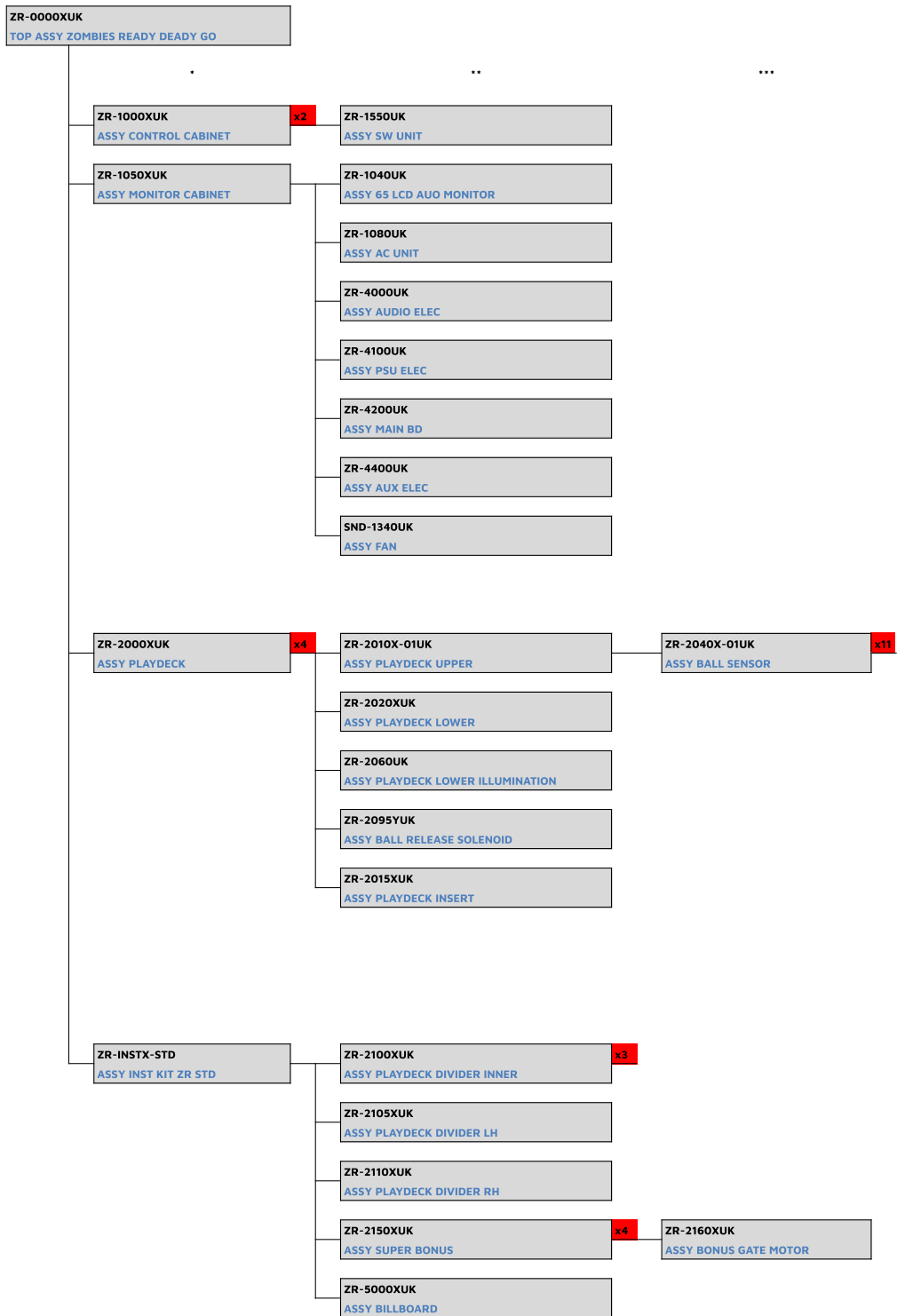

Please note: The location of all artwork can be found in Chapter 16 of this Manual.

# 1 TOP ASSY ZOMBIES RDG (ZR-0000XUK)

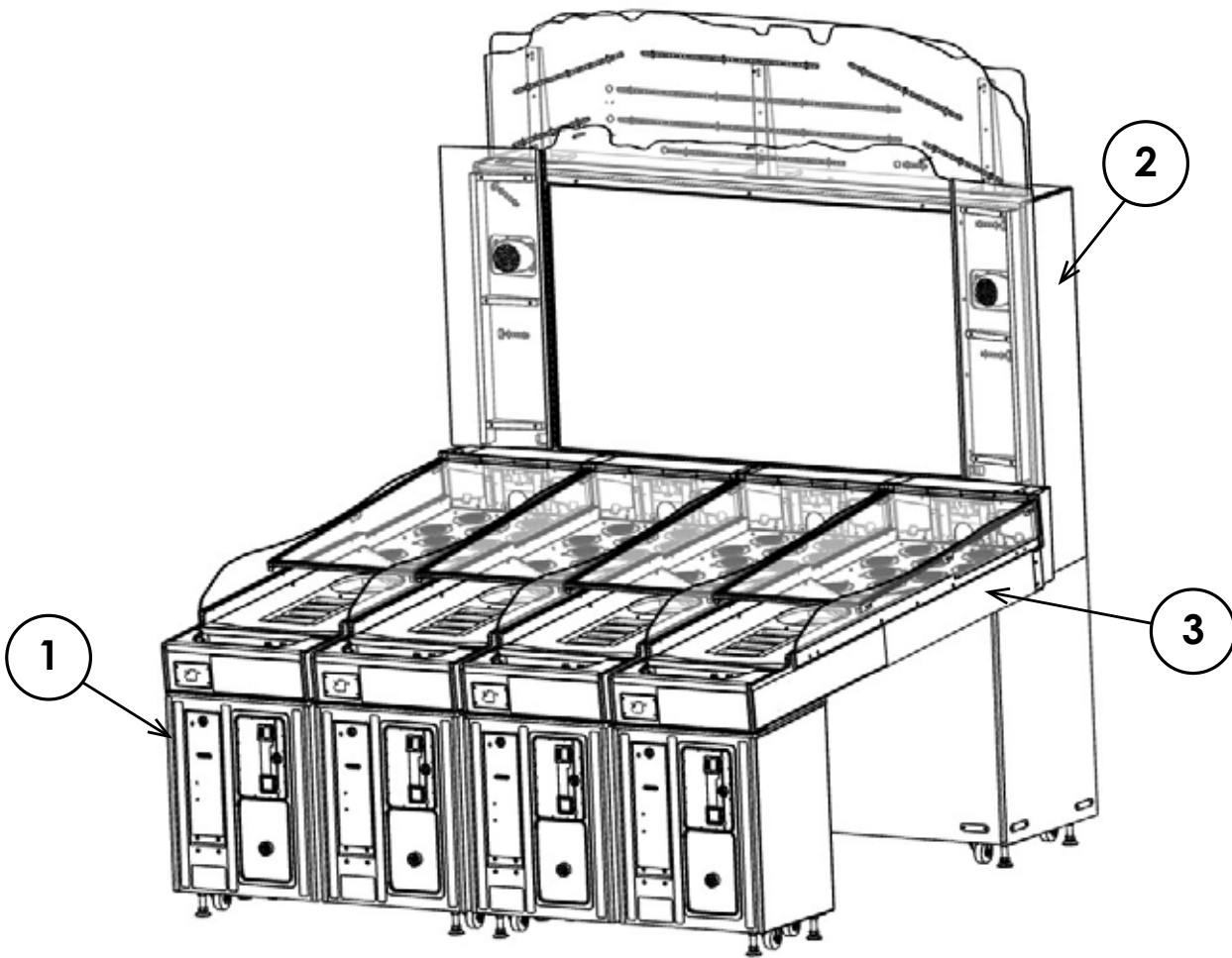

ITEM NO	PART NO	DESCRIPTION	QTY
*1	ZR-1000XUK	ASSY CONTROL CABINET	2
*2	ZR-1050XUK	ASSY MONITOR CABINET	1
*3	ZR-2000XUK	ASSY PLAYDECK	4
*9	ZR-0001UK	BATTEN PLAYDECK TRANSIT	4
*10	ZR-0002UK	BLOCK PLAYDECK TRANSIT	4
*202	029-B00640	M6X40 SKT BH PAS	16
*203	060-S00600	M6 WSHR SPR PAS	16
*204	068-652016	M6 WSHR 200D FLT PAS	16
*301	ZR-60024UK	WH PLAYER 1 FLOOR LIGHT	3
*302	ZR-60025UK	WH PLAYER 2 FLOOR LIGHT	3
*303	ZR-60026UK	WH PLAYER 3 FLOOR LIGHT	3
*304	ZR-60027UK	WH PLAYER 4 FLOOR LIGHT	3
*305	ZR-60029UK	WH P4 SIDE LED	1
*306	ZR-60038UK	WH PLAYER 1 SUPER BONUS LED	1
*307	ZR-60039UK	WH PLAYER 2 SUPER BONUS LED	1
*308	ZR-60040UK	WH PLAYER 3 SUPER BONUS LED	1
*309	ZR-60041UK	WH PLAYER 4 SUPER BONUS LED	1

Please note: The location of all labels can be found in Chapter 1 of this Manual.

② ASSY CONTROL CABINET (ZR-1000XUK)

(1/2)

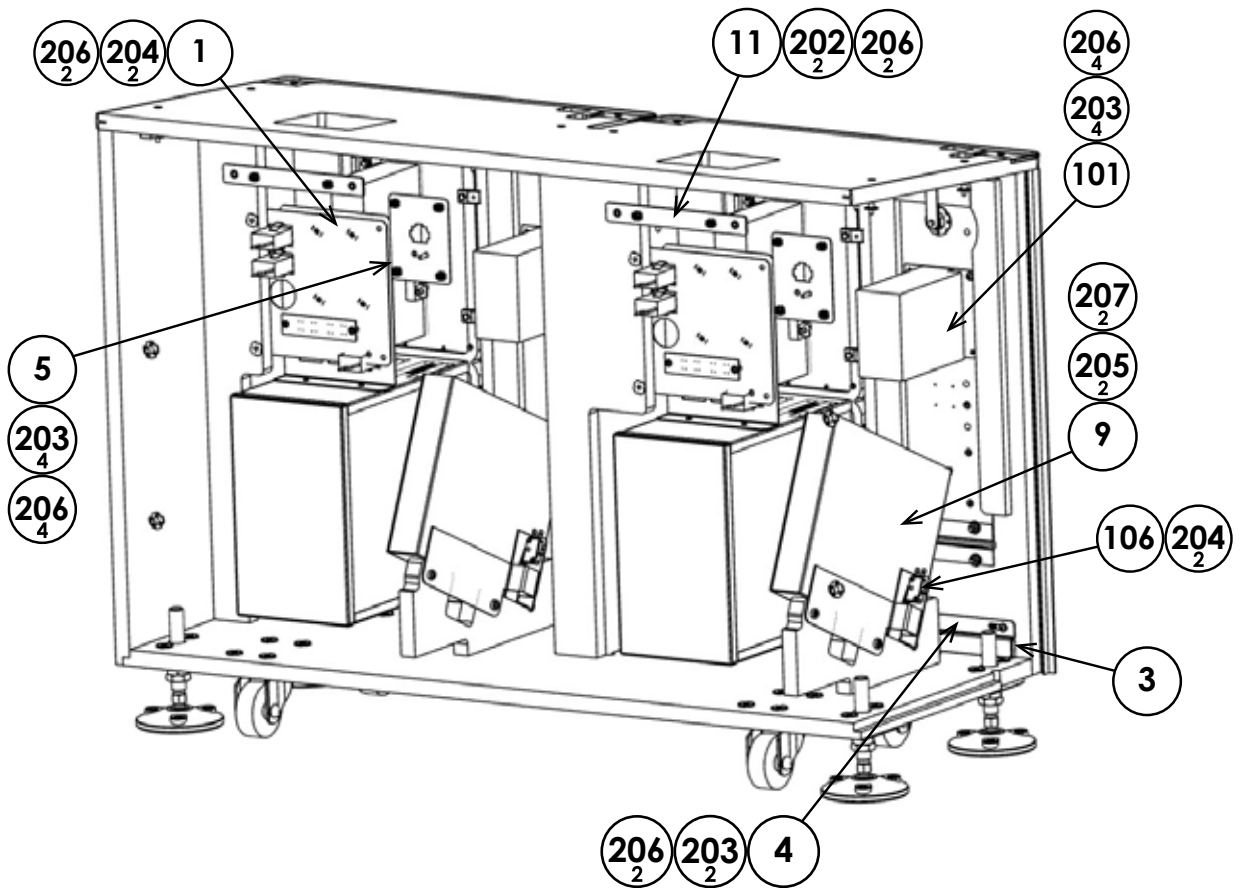
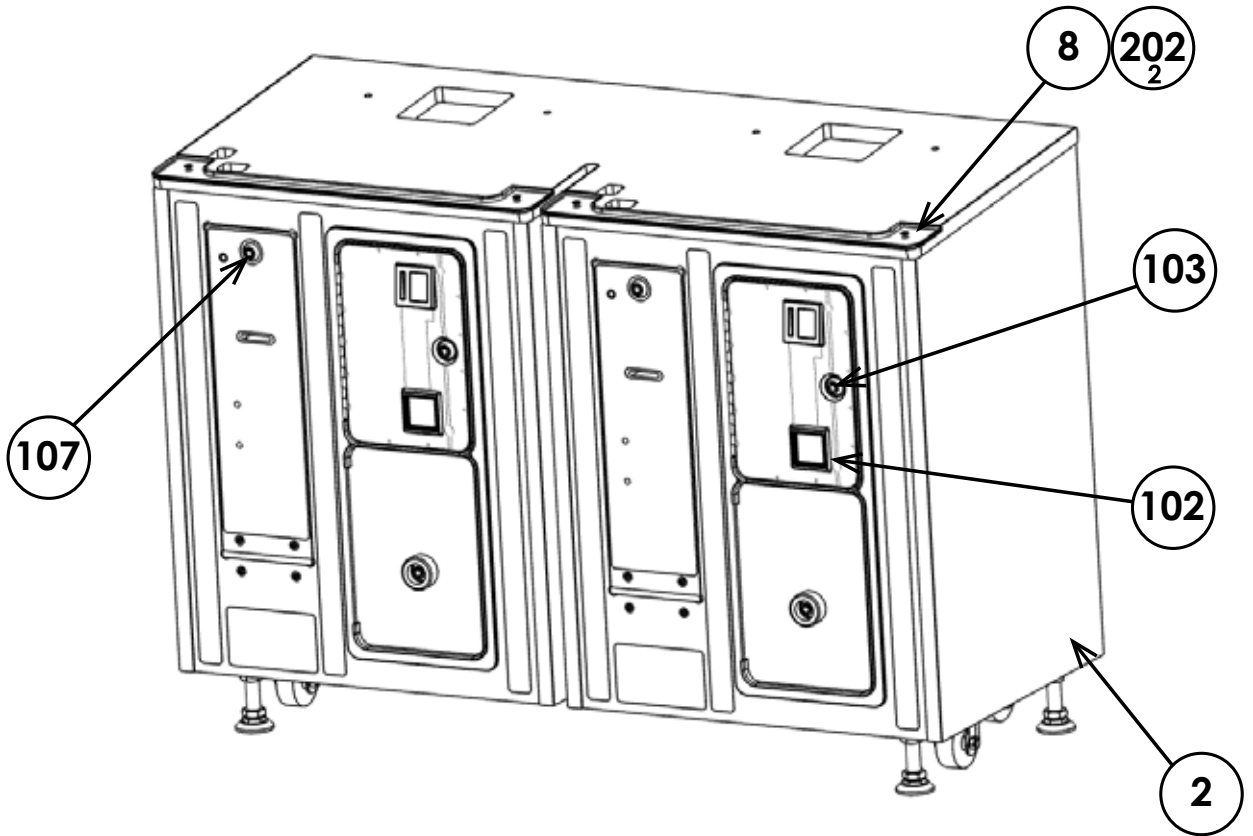

**2** ASSY CONTROL CABINET (ZR-1000XUK)

(2/2)

ITEM NO	PART NO	DESCRIPTION	QTY
**1	ZR-1550UK	ASSY SW UNIT	2
**2	ZR-1002XUK	ASSY FRONT CABINET	1
**3	ZR-1003XUK	PANEL FRONT CABI DOWNLIGHT	2
**4	ZR-1004XUK	BRKT FRONT CABI DOWNLIGHT	2
**5	ZR-1006UK	PLATE FRONT PANEL MNT	2
**8	ZR-1012XUK	PANEL FRONT LED STRIP	2
**9	BI-1106UK	HOLDER TICKET	2
**11	ZR-0023UK	PLATE M6 NUT	4
**101	220-0001-01UK	TICKET VEND UNIT TD-963CR	2
**102	220-5736-01	DFMD W/UNIV CRADLE&CASHBOX ENC HI SEC	2
**103	220-5575UK	LOCK (J9117) KEY TO LIKE 22MM W CAM	2
**104	280-A01264-WX	ROUTER TWIST D12 SO6.4 WOOD XL	16
**105	601-0460	CABLE TIE NYLON 100MM	6
**106	EP1420	SW MICRO LEVER RS	2
**107	EP1421	LED 12V RED RS 541-4072	2
**108	SAI-6108-0500UK	WH ASSY LED 500MM	2
**109	SAI-6108-0360UK	WH ASSY LED 360MM	2
**201	029-B00316	M3X16 SKT BH PAS	4
**202	000-F00412	M4X12 MSCR CSK PAS	12
**203	029-B00412	M4X12 SKT BH PAS	20
**204	029-B00425	M4X25 SKT BH PAS	4
**205	029-B00625	M6X25 SKT BH PAS	4
**206	060-F00400	M4 WSHR FORM A FLT PAS	32
**207	068-652016	M6 WSHR 20OD FLT PAS	4
**301	ZR-60019UK	WH CONTROL CAB LINK	2
**302	ZR-60031UK	WH TICKET VEND	2

### 3 ASSY 65 LCD MONITOR (ZR-1040UK)

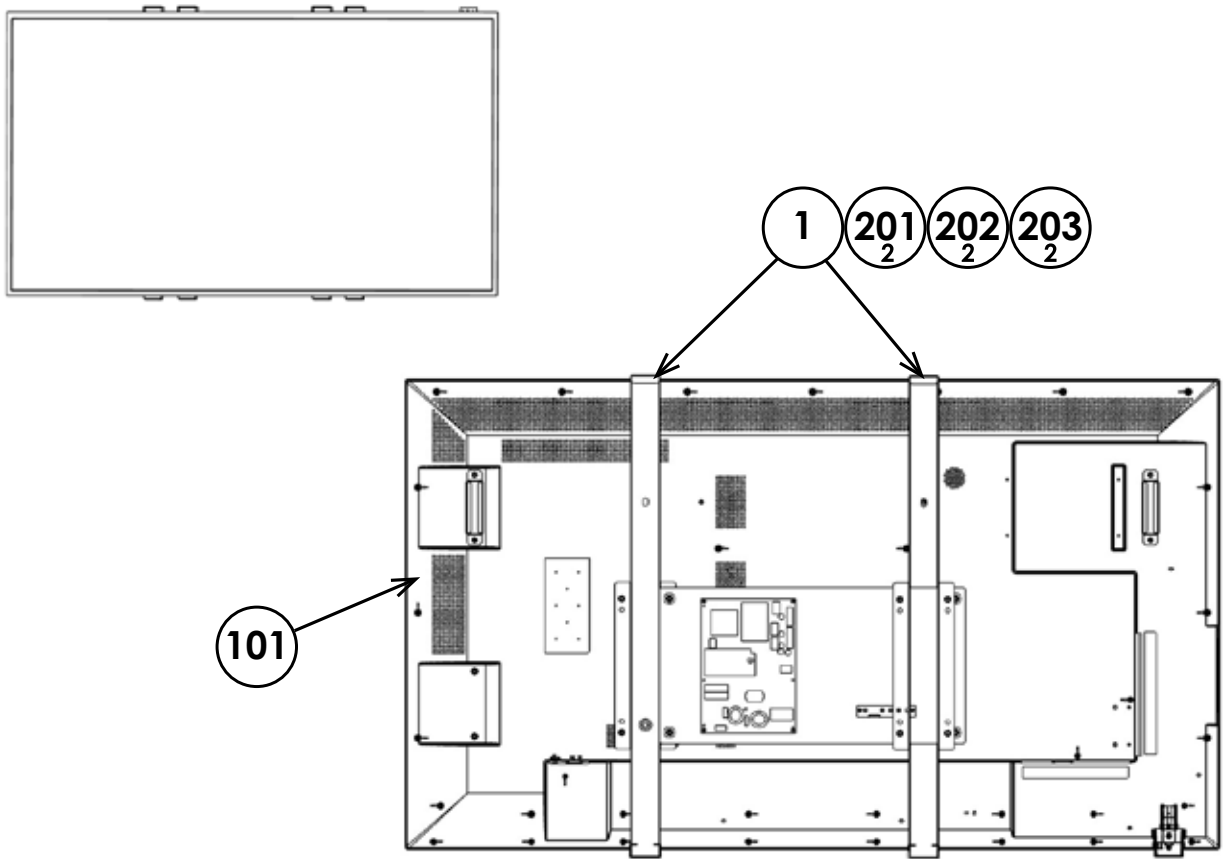

ITEM NO	PART NO	DESCRIPTION	QTY
***1	ZR-1041UK	BRKT MON65 SUPPORT	2
***101	200-6065-04-WEI	DISPLAY 65" LED MTV65W-CV1RS	1
***102	OS1230	FOAM STRIP 2mm X 10mm	4.5m
***201	029-B00616	M6X16 SKT BH PAS	4
***202	060-S00600	M6 WSHR SPR PAS	4
***203	068-652016	M6 WSHR 20OD FLT PAS	4
***301	ZR-60002UK	WH AC TO MONITOR	1

④ ASSY MONITOR CABINET (ZR-1050XUK)

(1/2)

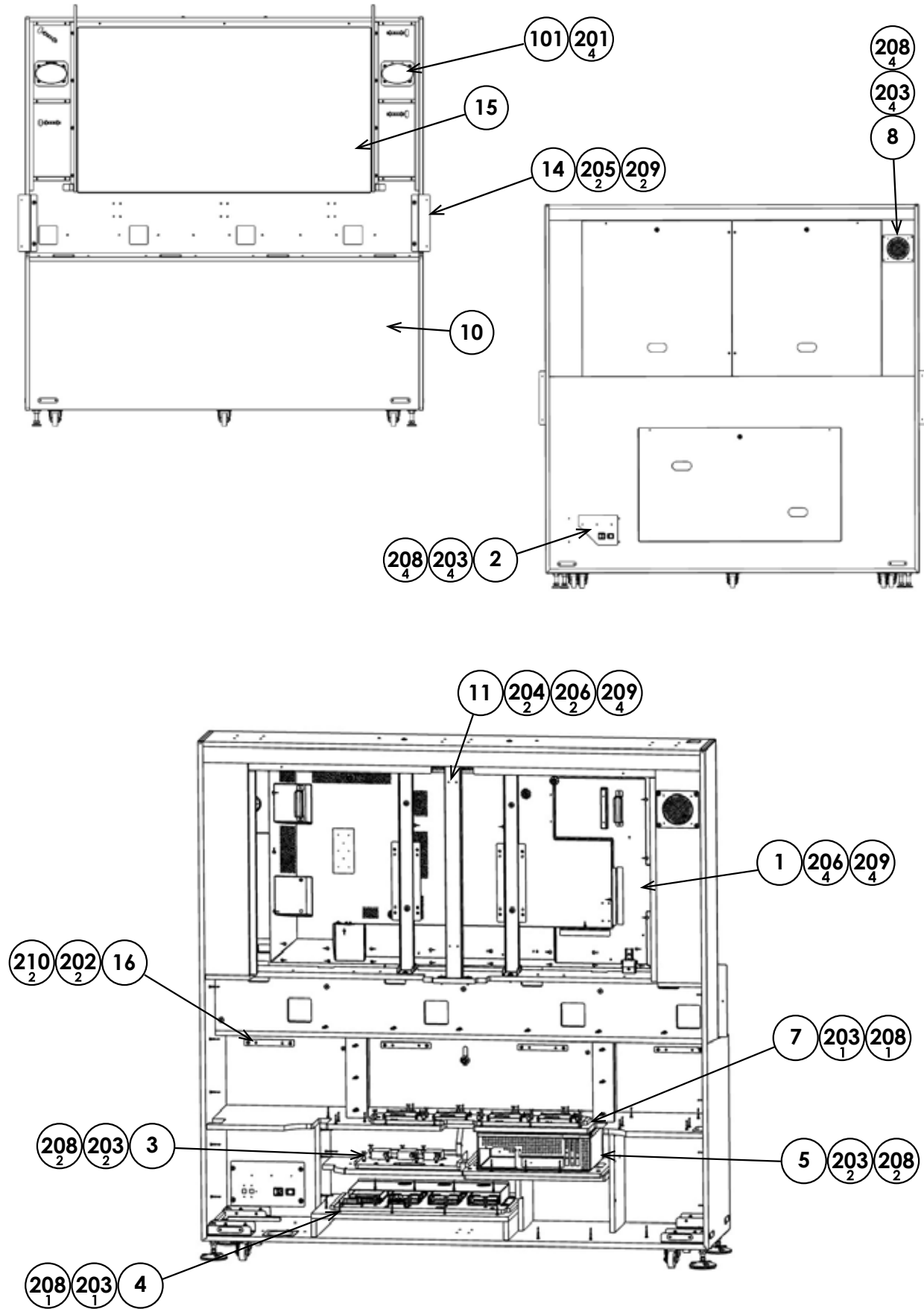

④ ASSY MONITOR CABINET (ZR-1050XUK)

(2/2)

ITEM NO	PART NO	DESCRIPTION	QTY
***1	ZR-1040UK	ASSY 65 LCD AUO MONITOR	1
***2	ZR-1080UK	ASSY AC UNIT	1
***3	ZR-4000UK	ASSY AUDIO ELEC	1
***4	ZR-4100UK	ASSY PSU ELEC	1
***5	ZR-4200UK	ASSY MAIN BD	1
***7	ZR-4400UK	ASSY AUX ELEC	1
***8	SND-1340UK	ASSY FAN	1
***10	ZR-1051UK	ASSY REAR CABINET	1
***11	ZR-1052UK	STRUT SUPPORT REAR UPPER DOOR SPLIT	1
***14	ZR-1071UK	PLATE CLOSING JOGGLE	2
***15	DSD-9602YUK	GLASS SCREEN PROTECT	1
***16	ZR-0023UK	PLATE M6 NUT	4
***101	130-04030-E	SPKR ELIP 4OHM 30W VIS Dx4x6P	1
***103	SAI-6503-0080UK	WH ASSY LED 80MM	4
***201	012-P03512-F	N6X1/2" S/TAP FLG PAS	8
***202	029-B00412	M4X12 SKT BH PAS	8
***203	029-B00425-0B	M4X25 SKT BH BLK	14
***204	029-B00612	M6X12 SKT BH PAS	2
***205	029-B00625	M6X25 SKT BH PAS	4
***206	029-B00630	M6X30 SKT BH PAS	6
***208	068-441616-0B	M4 WSHR 16OD FLT BLK	14
***209	068-652016	M6 WSHR 20OD FLT PAS	12
***210	060-F00400	M4 WSHR FORM A FLT PAS	8
***301	ZR-60009UK	WH POWER TO IO2'S	1
***302	ZR-60012UK	WH POWER TO PLAYERS	1
***303	ZR-60013UK	WH MON CAB TOP CONNECT	1
***304	ZR-60014UK	WH MON CAB LIGHT FAN SPKR L	1
***305	ZR-60015UK	WH MON CAB SPKR R	1
***306	ZR-60034UK	WH AUDIO TO PLAYERS	1
***307	MI-60017UK	WH SPEAKER A	2
***308	ZR-60044UK	WH IO TO PLAYERS 1&2	1
***309	ZR-60045UK	WH IO TO PLAYERS 3&4	1
***310	600-9200-44K	M4 RING TO RING EARTH 2M	1
***311	600-9040-44K	M4 RING TO RING EARTH 0.4M	1



## 5 ASSY AC UNIT (ZR-1080UK)

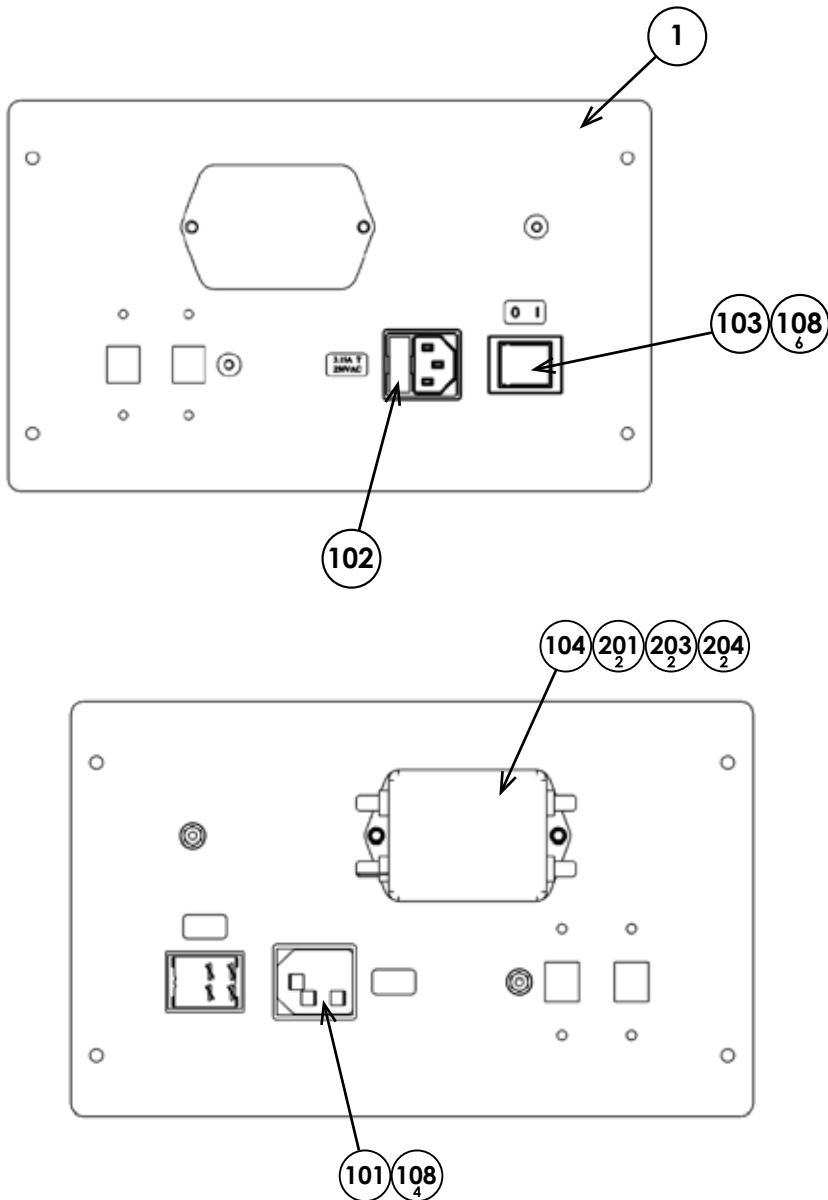

ITEM NO	PART NO	DESCRIPTION	QTY
***1	DA-1081UK	PLATE AC	1
***101	EP1302	EUROSOCKET FUSED 10A 250VAC	1
***102	514-5078-5000	FUSE 5.00 X 20 CERAMIC SB 5000mA	2
***103	SW1109	SWITCH ROCKER 250V AC	1
***104	EP1419	FILTER SCHAFFNER 2030-16-06	1
***108	310-5029-D508	HEAT SHRINK SLEEVING 50.8DIA	10
***201	029-B00408	M4X8 SKT BH PAS	2
***202	050-F00400	M4 NUT FLG SER PAS	6
***203	060-F00400	M4 WSHR FORM A FLT PAS	2
***204	060-S00400	M4 WSHR SPR PAS	2
***301	DA-60101UK	WH AC IN	1

⑥ ASSY SW UNIT (ZR-1550UK)

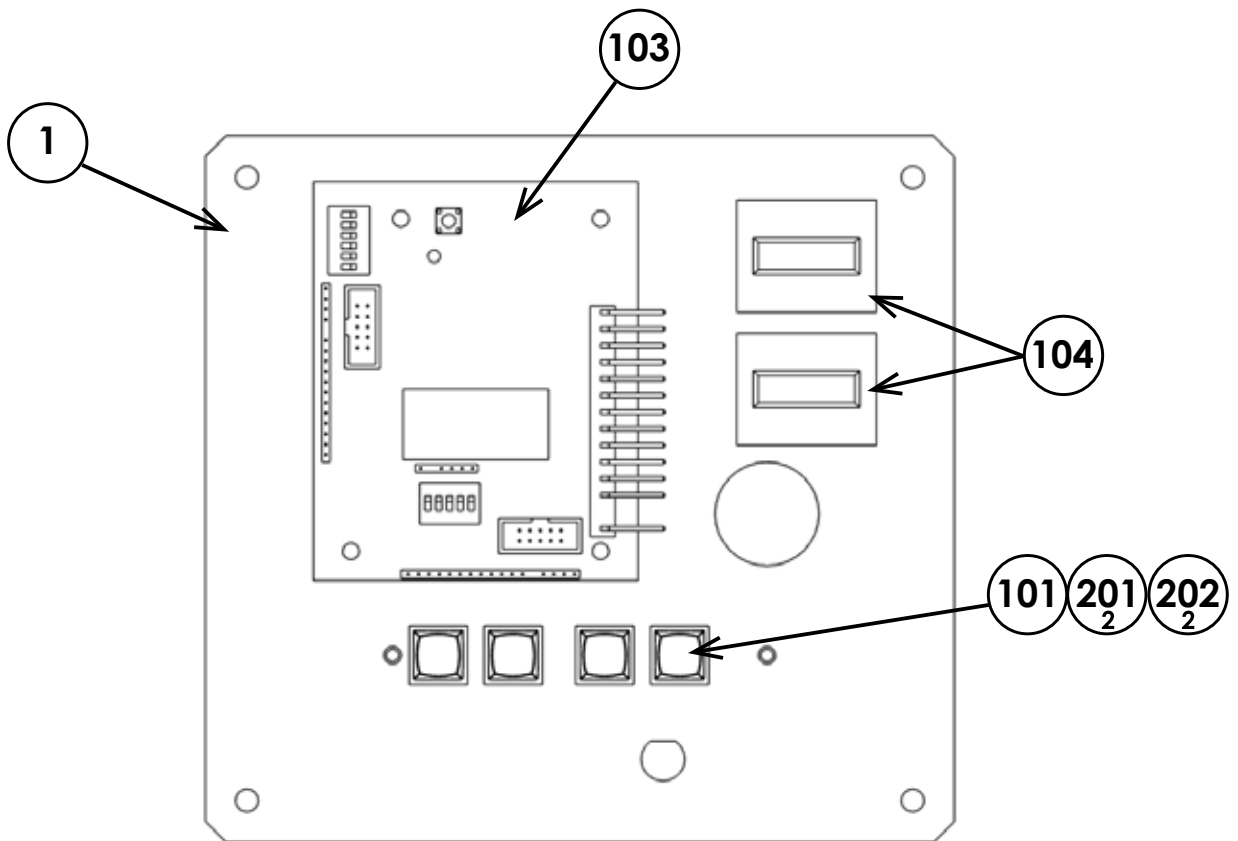

ITEM NO	PART NO	DESCRIPTION	QTY
***1	ZR-1551UK	BRKT SW DIGITAL VOL CTRL	1
***101	838-0058UK	DIGITAL SW VOL BOARD	1
***102	280-L00706-PM	STANDOFF 6.4MM HOLE PM	4
***103	EP1380-01	CREDIT BOARD EXCEL	1
***104	220-5643UK	COIN METER SMALL 12V	2
***105	OS1247	ALUMINIUM STICKY CLIP ASK-3	1
***107	OS1098	CRIMP BELL END SMALL	4
***108	601-0460	CABLE TIE NYLON 100MM	2
***201	000-P00308	M3X8 MSCR PAN PAS	2
***202	068-330808-PN	M3 WSHR 80D FLT NYLON	2
***301	ZR-60030UK	WH COIN VTS	1

7 ASSY PLAYDECK (ZR-2000XUK)

(1/2)

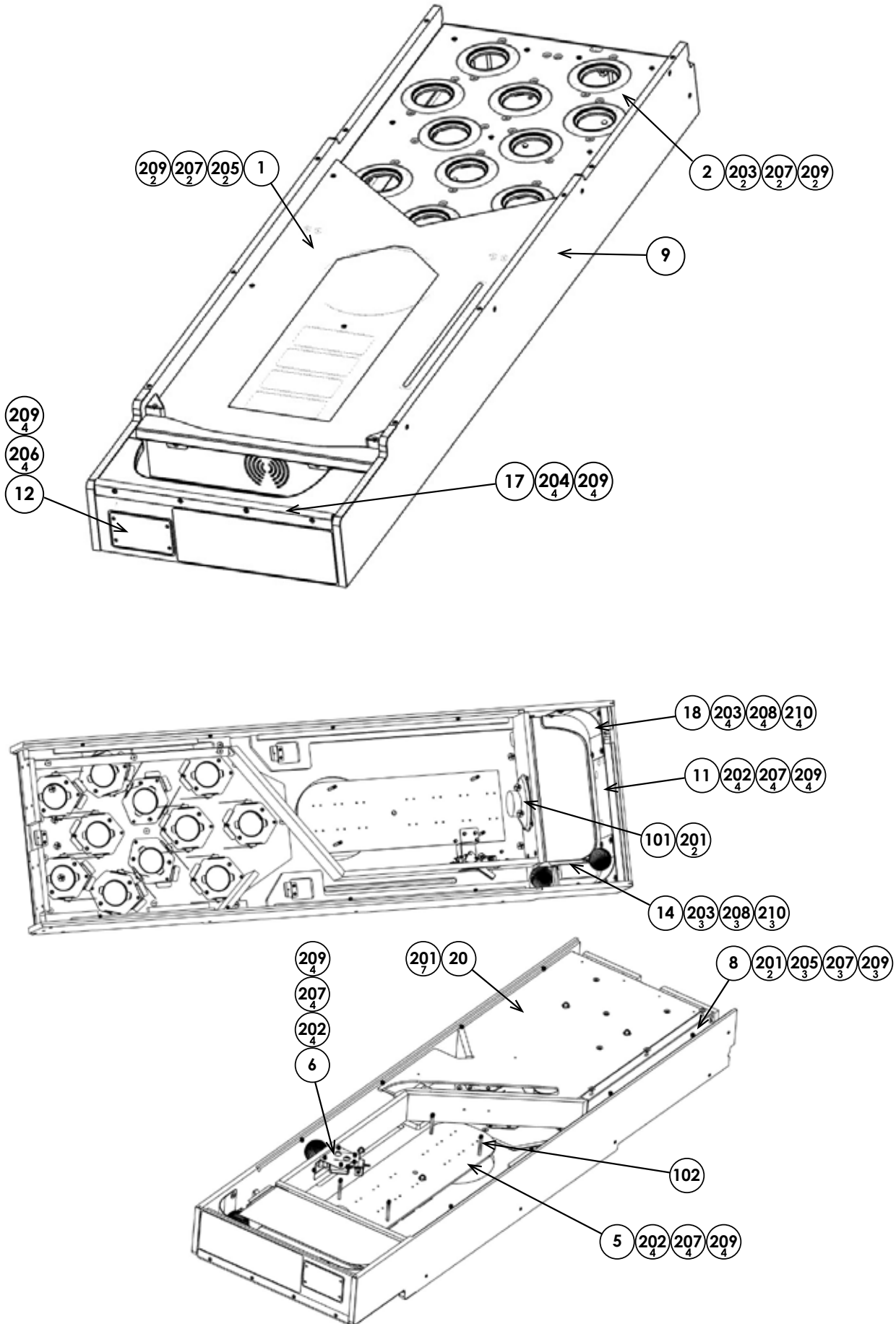

7 ASSY PLAYDECK (ZR-2000XUK)

(2/2)

ITEM NO	PART NO	DESCRIPTION	QTY
***1	ZR-2010X-01UK	ASSY PLAYDECK UPPER	1
***2	ZR-2020XUK	ASSY PLAYDECK LOWER	1
***5	ZR-2060UK	ASSY PLAYDECK LOWER ILLUMINATION	1
***6	ZR-2095YUK	ASSY BALL RELEASE SOLENOID	1
***8	ZR-2001XUK	SHIELD HARNESS	1
***9	ZR-2002XUK	ASSY PLAYFIELD CABINET	1
***11	ZR-2004XUK	COVER CARD READER MOUNT	1
***12	ZR-2006XUK	PLATE CARD READER BLANKING	1
***14	ZR-2008XUK	COVER BALL RETURN	1
***17	ZR-2028XUK	TRIM BALL COLLECT	1
***18	ZR-2037XUK	COVER PLAYDECK CORNER	2
***20	ZR-2015XUK	ASSY PLAYDECK INSERT	1
***101	130-04030-E	SPKR ELIP 4OHM 30W VIS Dx4x6P	1
***102	280-0010UK	M4X50 SPACER HEX 7AF 50L PAS-304450041152	4
***201	012-P03512-F	N6X1/2" S/TAP FLG PAS	13
***202	029-B00412	M4X12 SKT BH PAS	8
***203	029-B00412-0B	M4X12 SKT BH BLK	11
***204	029-B00416	M4X16 SKT BH PAS	4
***205	029-B00425	M4X25 SKT BH PAS	5
***206	050-F00400	M4 NUT FLG SER PAS	4
***207	060-S00400	M4 WSHR SPR PAS	13
***208	060-S00400-0B	M4 WSHR SPR BLK	11
***209	068-441616	M4 WSHR 16OD FLT PAS	21
***210	068-441616-0B	M4 WSHR 16OD FLT BLK	11
***211	000-F00420-0B	M4X20 MSCR CSK BLK	4
***212	029-B00625-0B	M6X25 SKT BH BLK	2
***213	060-S00400-0B	M4 WSHR SPR BLK	2
***214	068-652016-0B	M4 WSHR 20OD FLT BLK	2
***301	ZR-60016UK	WH PLAYDECK LINK	1
***302	ZR-60018UK	WH BALL CONTROL	1
***303	ZR-60046UK	WH MOTOR HARNESS	1

## 8 ASSY PLAYDECK UPPER (ZR-2010X-01UK)

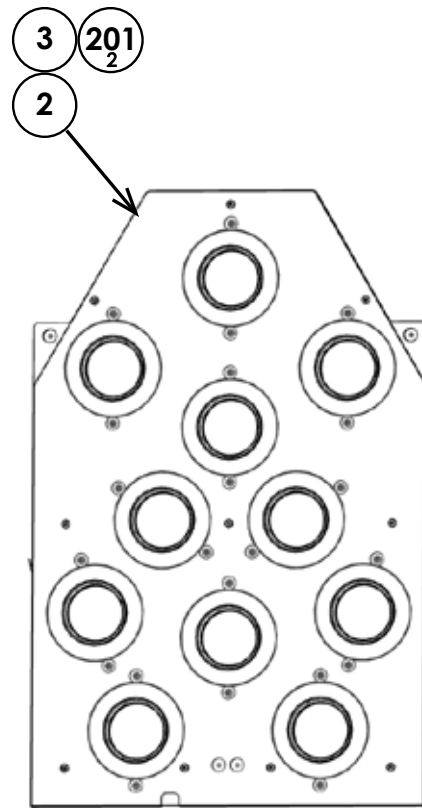
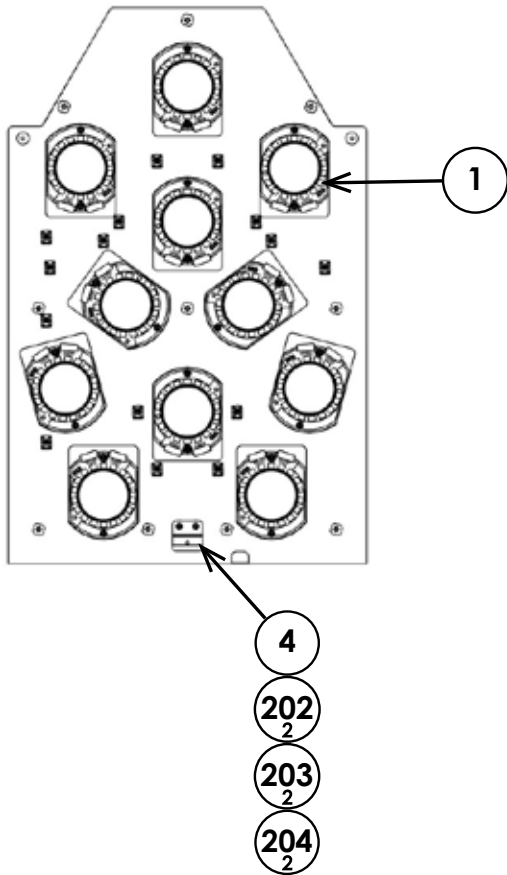

ITEM NO	PART NO	DESCRIPTION	QTY
***1	ZR-2040X-01UK	ASSY BALL SENSOR	11
***2	ZR-2011X-01UK	BOARD PLAYDECK UPPER	1
***4	ZR-2013XUK	BRKT PLAYDECK BOARD	1
***101	280-0023UK	FLAT CABLE CLIP 6.4MM SFCC-4-01	15
***201	000-F00412	M4X12 MSCR CSK PAS	10
***202	029-B00416	M4X16 SKT BH PAS	2
***203	060-S00400	M4 WSHR SPR PAS	2
***204	060-F00400	M4 WSHR FORM A FLT PAS	2
***205	012-P03506-F	N6X1/4" S/TAP FLG PAS	15
***301	ZR-60505UK	WH PLAYDECK ZONE 1	1
***302	ZR-60506UK	WH PLAYDECK ZONE 2	1
***303	ZR-60507UK	WH PLAYDECK ZONE 3	1
***304	SAI-6011-0200UK	WH RIBBON CABLE 12P 200MM	8

⑨ ASSY PLAYDECK INSERT (ZR-2015XUK)

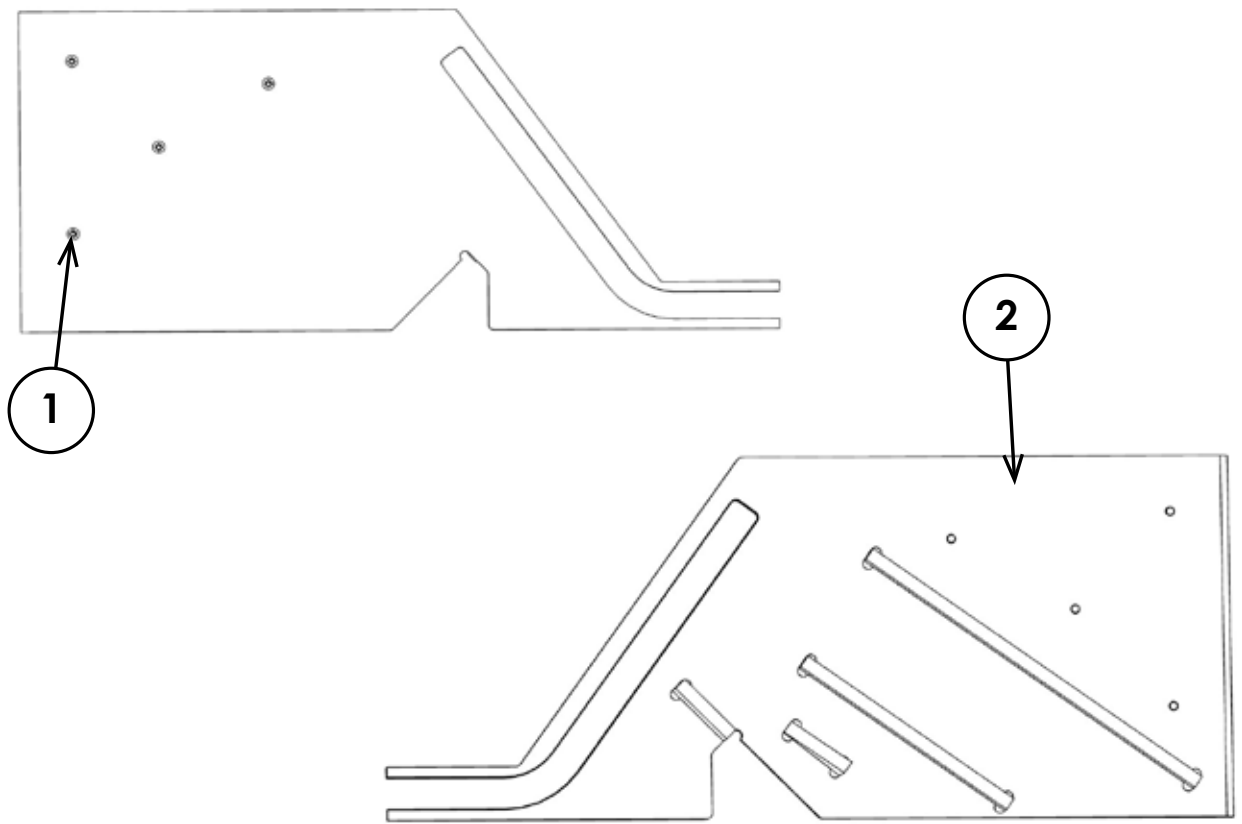

ITEM NO	PART NO	DESCRIPTION	QTY
***1	ZR-2018XUK	INSERT PLAYDECK	1
***2	ZR-2019XUK	PIN BALL DIVERT	4

## 10 ASSY PLAYDECK LOWER (ZR-2020XUK)

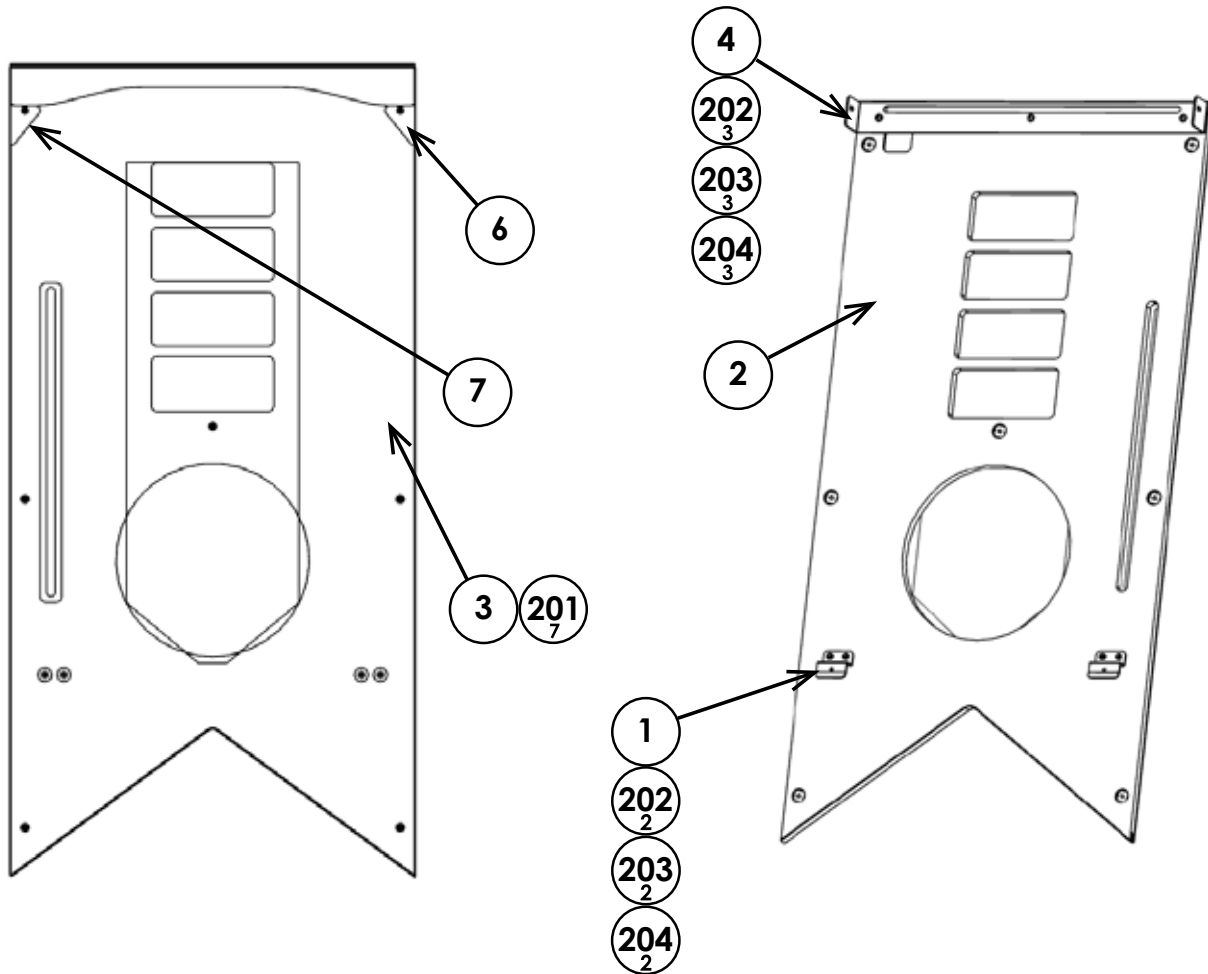

ITEM NO	PART NO	DESCRIPTION	QTY
***1	ZR-2013XUK	BRKT PLAYDECK BOARD	2
***2	ZR-2021XUK	BOARD PLAYDECK LOWER	1
***4	ZR-2031XUK	TRIM PLAYDECK LOWER	1
***5	ZR-2053XUK	COVER BALL COLLECT LED	1
***6	ZR-2023UK	DIVERter BALL LH	1
***7	ZR-2024UK	DIVERter BALL RH	1
***101	SAI-6108-0360UK	WH ASSY LED 0360MM	1
***201	000-F00412	M4X12 MSCR CSK PAS	5
***202	029-B00416	M4X16 SKT BH PAS	7
***203	060-S00400	M4 WSHR SPR PAS	7
***204	060-F00400	M4 WSHR FORM A FLT PAS	9
***205	029-B00425	M4X25 SKT BH PAS	2
***301	MI-60017UK	WH SPEAKER A	1



11 ASSY BALL SENSOR (ZR-2040X-01UK)

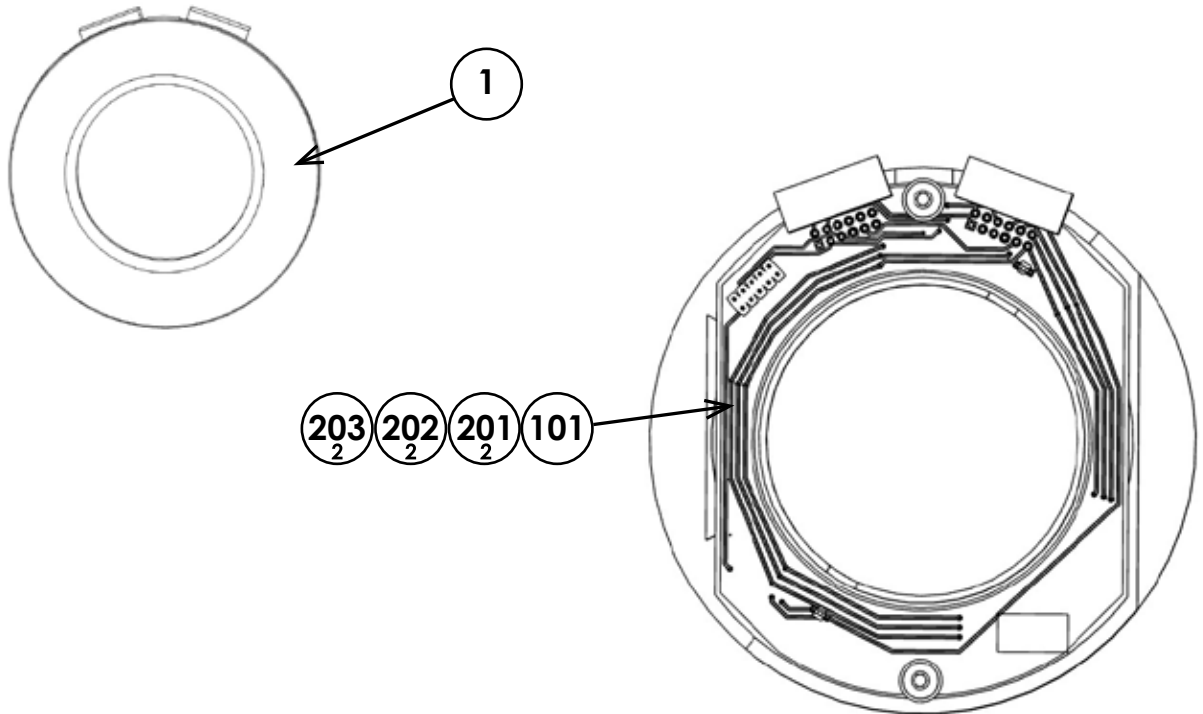

ITEM NO	PART NO	DESCRIPTION	QTY
****1	ZR-2041X-01UK	BLOCK BALL SENSOR	1
****101	838-0066UK	RGB IR RING	1
****201	029-B00408	M4X8 SKT BH PAS	2
****202	060-S00400	M4 WSHR SPR PAS	2
****203	060-F00400	M4 WSHR FORM A FLT PAS	2

12 ASSY PLAYDECK LOWER ILLUMINATION (ZR-2060UK)

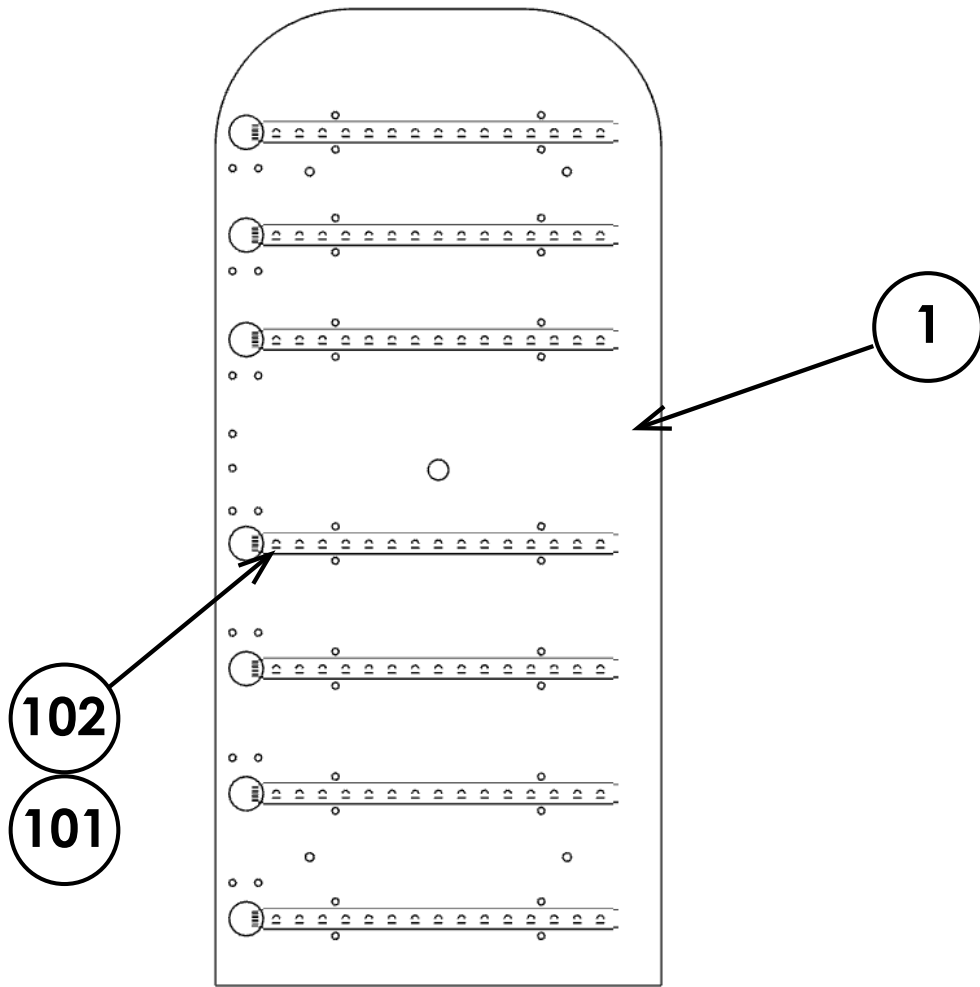

ITEM NO	PART NO	DESCRIPTION	QTY
***1	ZR-2061UK	PANEL PLAYDECK ILLUMINATION	1
***101	601-0460	CABLE TIE NYLON 100MM	14
***102	SAI-6603-0200UK	WH ASSY LED 200MM	7

### 13 ASSY BALL RELEASE SOLENOID (ZR-2095YUK)

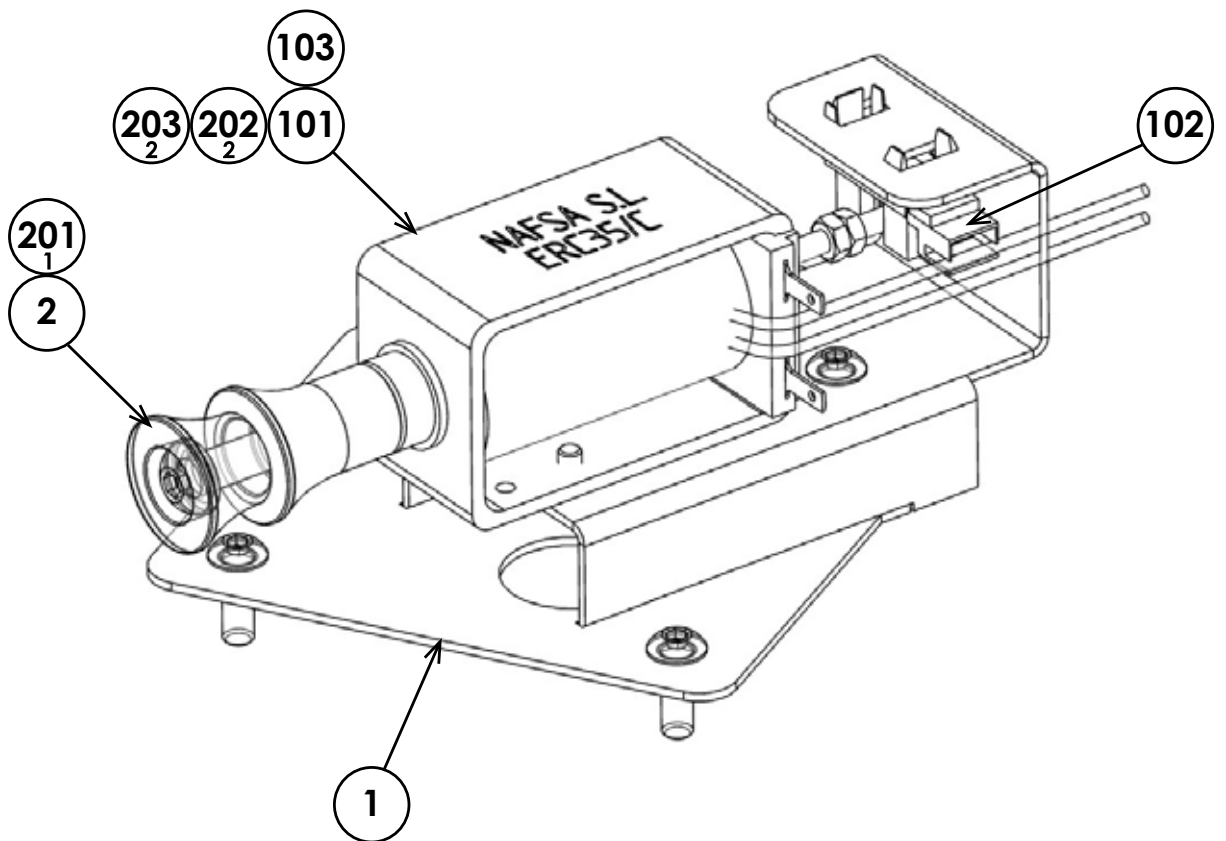

ITEM NO	PART NO	DESCRIPTION	QTY
***1	ZR-2096YUK	BRKT SOLENOID MTG	1
***2	ZR-2097YUK	ENDCAP SOLENOID	1
***101	124-0003-01UK	SOL NAFSA ERC35.01.12.100.CC 12VDC	1
***102	EP1434	OPTIC SENSOR GAMESMA	1
***103	310-5029-D03	HEAT SHRINK SLEEVING 3DIA	1.5cm
***104	OS1098	CRIMP BELL END SMALL	2
***201	029-B00520	M5X20 SKT BH PAS	1
***202	029-B00306	M3X6 SKT BH PAS	2
***203	060-S00300	M3 WSHR SPR PAS	2

15 ASSY PLAYDECK DIVIDER INNER (ZR-2100XUK)

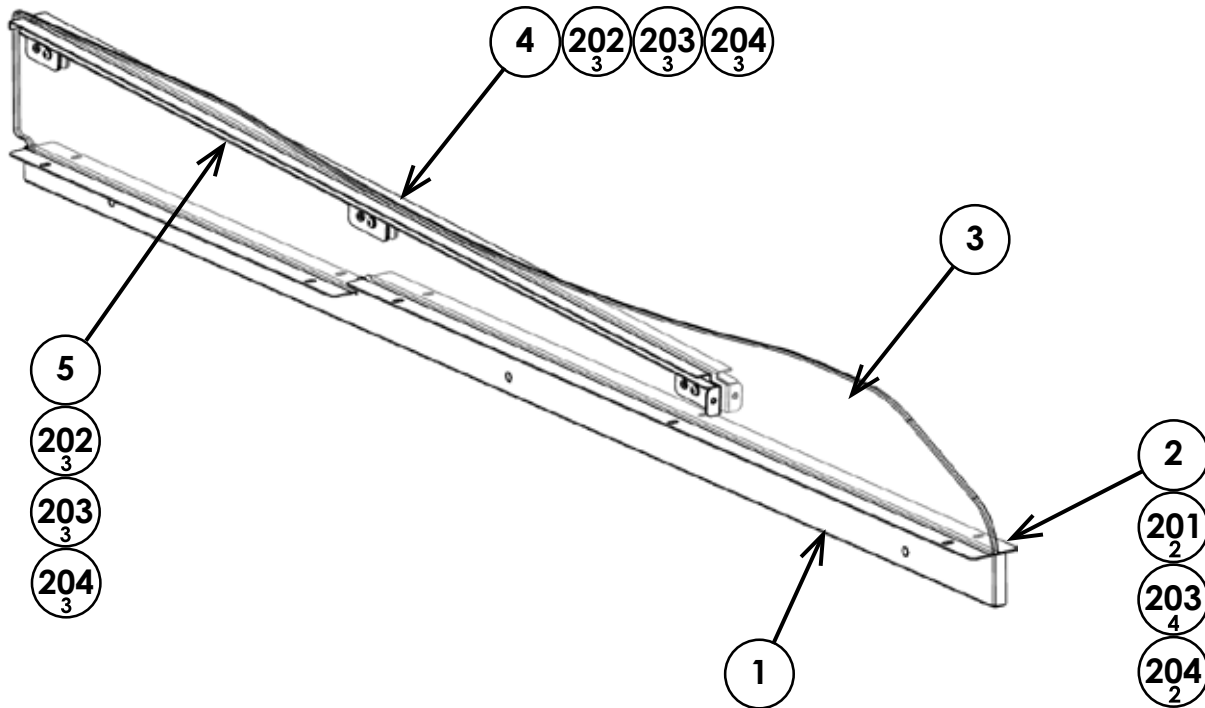

ITEM NO	PART NO	DESCRIPTION	QTY
***1	ZR-2101XUK	BASE PLAYDECK DIVIDER INNER	1
***2	ZR-2102XUK	COVER PLAYDECK DIVIDER INNER	1
***3	ZR-2103XUK	PANEL PLAYDECK DIVIDER	1
***4	ZR-2121XUK	SUPPORT CHEAT PANEL LH	1
***5	ZR-2122XUK	SUPPORT CHEAT PANEL RH	1
***101	SAI-6108-1350UK	WH ASSY LED 1350MM	1
***201	029-B00408-0B	M4X8 SKT BH BLK	3
***202	029-B00416-0B	M4X16 SKT BH BLK	6
***203	060-F00400-0B	M4 WSHR FORM A FLT BLK	9
***204	060-S00400-0B	M4 WSHR SPR BLK	9

16 ASSY PLAYDECK DIVIDER LH (ZR-2105XUK)

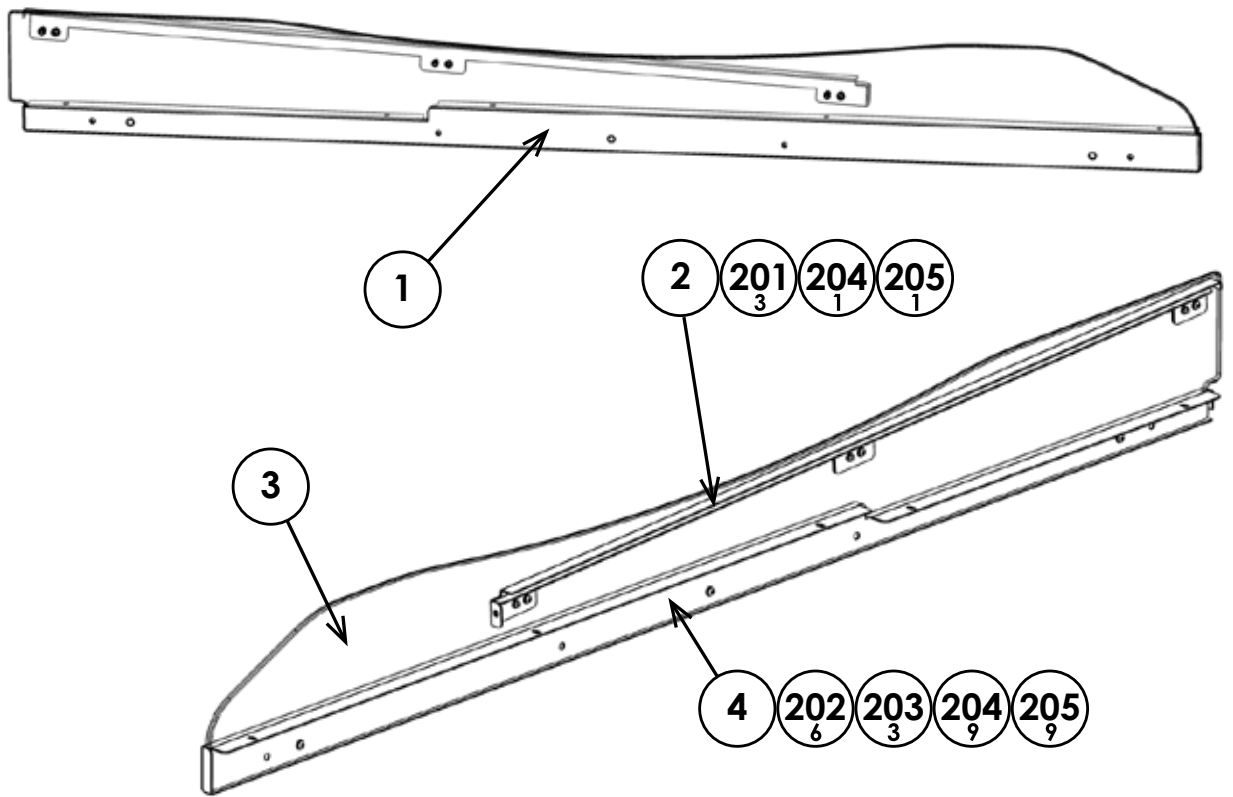

ITEM NO	PART NO	DESCRIPTION	QTY
***1	ZR-2106XUK	BASE PLAYDECK DIVIDER LH	1
***2	ZR-2102XUK	COVER PLAYDECK DIVIDER INNER	1
***3	ZR-2103XUK	PANEL PLAYDECK DIVIDER	1
***4	ZR-2121XUK	SUPPORT CHEAT PANEL LH	1
***101	SAI-6108-1350UK	WH ASSY LED 1350MM	1
***201	029-B00408-0B	M4X8 SKT BH BLK	3
***202	029-B00416-0B	M4X16 SKT BH BLK	6
***203	050-U00400	M4 NUT NYLOK PAS	3
***204	060-F00400-0B	M4 WSHR FORM A FLT BLK	12
***205	060-S00400-0B	M4 WSHR SPR BLK	12

## 17 ASSY PLAYDECK DIVIDER RH (ZR-2110XUK)

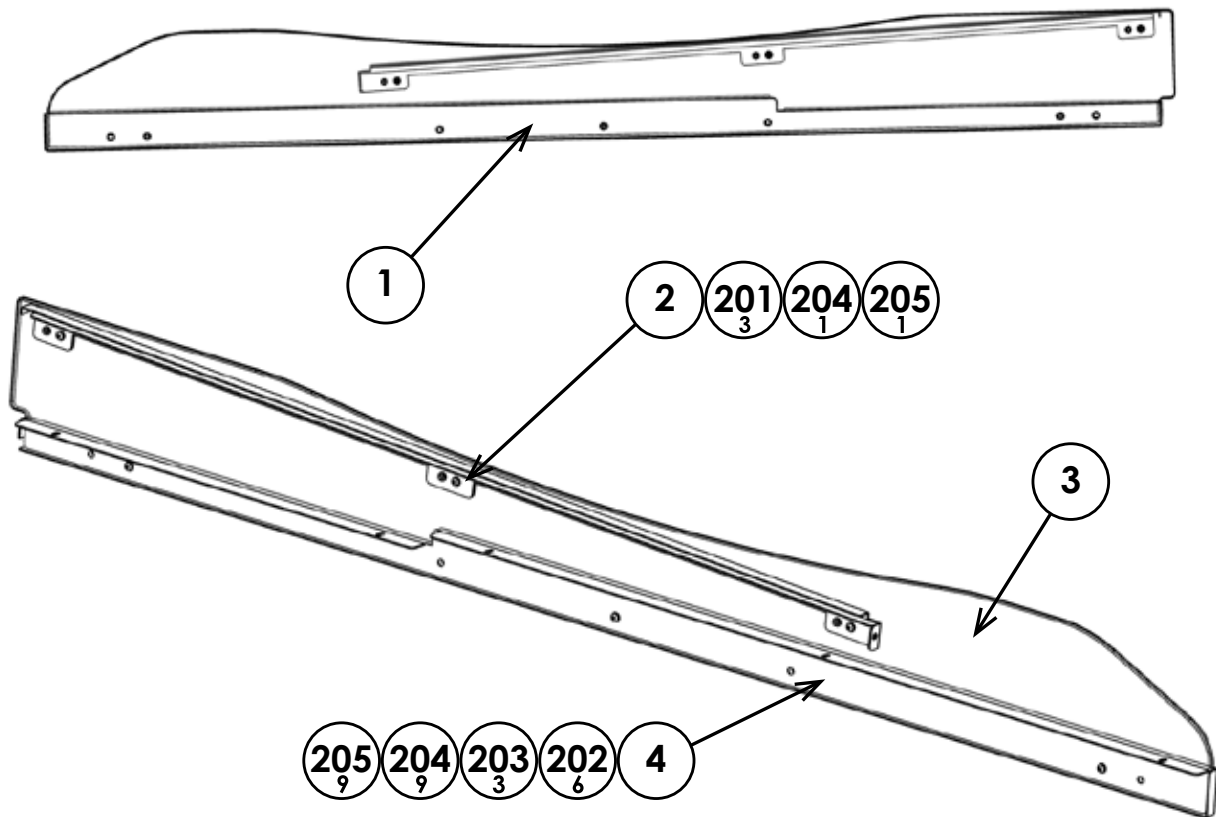

ITEM NO	PART NO	DESCRIPTION	QTY
***1	ZR-2107XUK	BASE PLAYDECK DIVIDER RH	1
***2	ZR-2108XUK	COVER PLAYDECK DIVIDER RH	1
***3	ZR-2103XUK	PANEL PLAYDECK DIVIDER	1
***4	ZR-2122XUK	SUPPORT CHEAT PANEL RH	1
***101	SAI-6108-1350UK	WH ASSY LED 1350MM	1
***201	029-B00408-0B	M4X8 SKT BH BLK	3
***202	029-B00416-0B	M4X16 SKT BH BLK	6
***203	050-U00400	M4 NUT NYLOK PAS	3
***204	060-F00400-0B	M4 WSHR FORM A FLT BLK	12
***205	060-S00400-0B	M4 WSHR SPR BLK	12

18 ASSY SUPER BONUS (ZR-2150XUK)

(1/2)

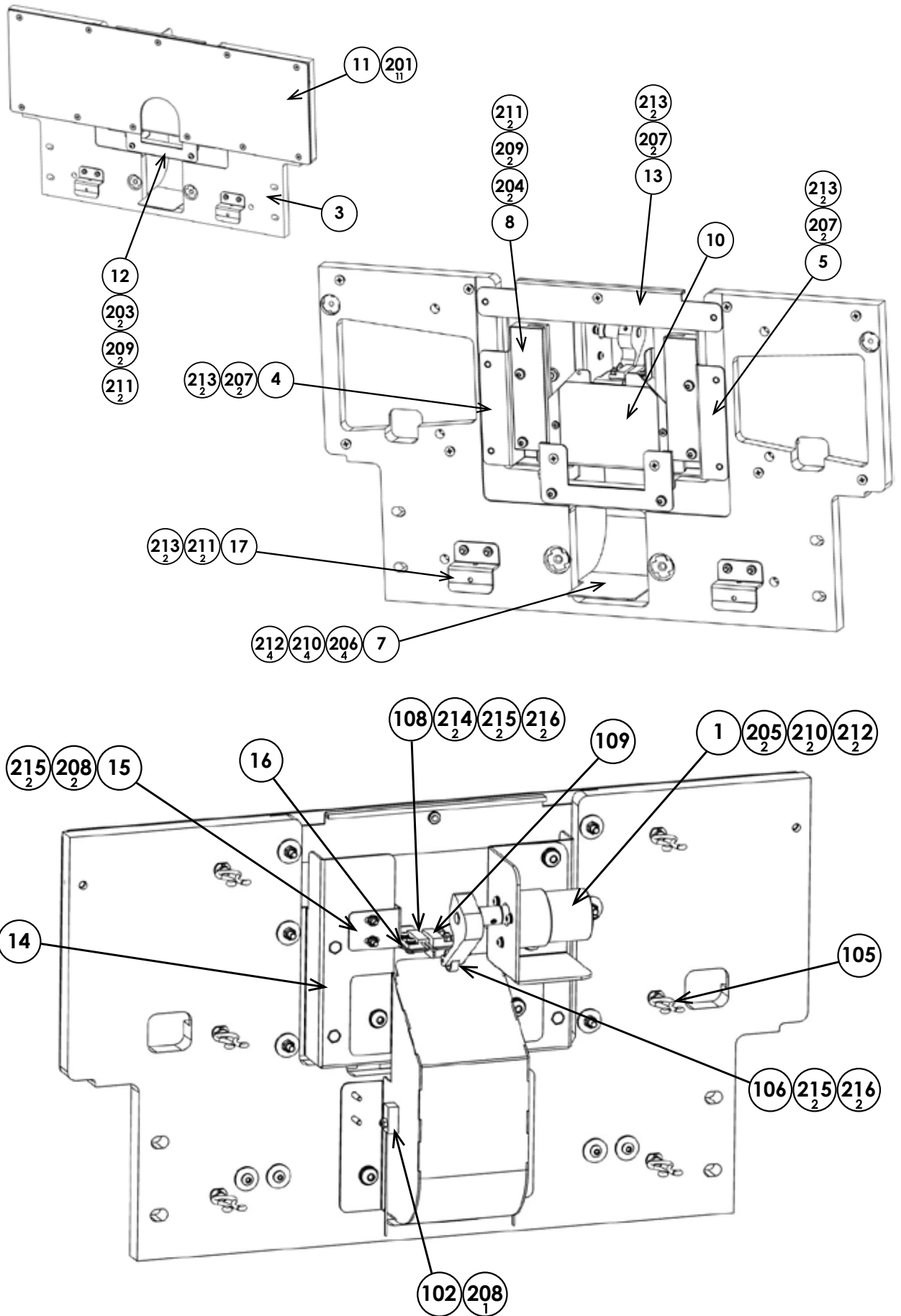



ITEM NO	PART NO	DESCRIPTION	QTY
***1	ZR-2160XUK	ASSY BONUS GATE MOTOR	1
***3	ZR-2152XUK	PANEL PLAYDECK BACK	1
***4	ZR-2153X-01UK	BRKT BONUS GATE LH	1
***5	ZR-2154X-01UK	BRKT BONUS GATE RH	1
***7	ZR-2161UK	CHUTE BONUS BALL RETURN	1
***8	ZR-2166XUK	GUIDE BONUS GATE	2
***9	ZR-2167UK	BRKT BONUS GATE SWITCH	1
***10	ZR-2168XUK	PLATE BONUS GATE	1
***11	ZR-2171X-AUK	SUPER BONUS PANEL	1
***12	ZR-2174XUK	SUPPORT SUPER BONUS LOWER	1
***13	ZR-2176XUK	SUPPORT SUPER BONUS UPPER	1
***15	ZR-2173XUK	BRKT REED SW ADJUST	1
***16	ZR-2179UK	PACKER REED SW	2
***17	ZR-2013XUK	BRKT PLAYDECK BOARD	2
***102	370-5173-01	PHOTO SENSOR OMT-15DJST-YL	1
***103	SAI-6108-0420UK	WH ASSY LED 420MM	2
***104	SAI-6509-0150UK	WH ASSY LED 150MM	1
***105	280-A01264-WX	ROUTER TWIST D12 S06.4 WOOD XL	6
***106	100-0014UK	BEARING MINI 3MM BORE MR93-ZZ	4
***107	EP1523	JST MALE SPADE TERM	2
***108	EP1406	REED SWITCH MP201801	1
***109	EP1408	MAGNET AS201801	1
***201	000-F00408	M4X8 MSCR CSK PAS	11
***203	029-B00412	M4X12 SKT BH PAS	2
***204	029-B00425	M4X25 SKT BH PAS	8
***205	029-B00612	M6X12 SKT BH PAS	4
***206	029-B00616	M6X16 SKT BH PAS	2
***207	050-U00400	M4 NUT NYLOK PAS	6
***208	050-U00300	M3 NUT NYLOK PAS	6
***209	060-F00400	M4 WSHR FORM A FLT PAS	6
***210	060-F00600	M6 WSHR FORM A FLT PAS	6
***211	060-S00400	M4 WSHR SPR PAS	10
***212	060-S00600	M6 WSHR SPR PAS	6
***213	068-441616	M4 WSHR 16OD FLT PAS	10
***214	029-B00308	M3X8 SKT BH PAS	6
***215	060-F00300	M3 WSHR FORM A FLT PAS	12
***216	060-S00300	M3 WSHR SPR PAS	2
***301	ZR-60028UK	WH BONUS	1
***302	ZR-60046UK	WH MOTOR HARNESS	1

## 19 ASSY BONUS GATE MOTOR (ZR-2160XUK)

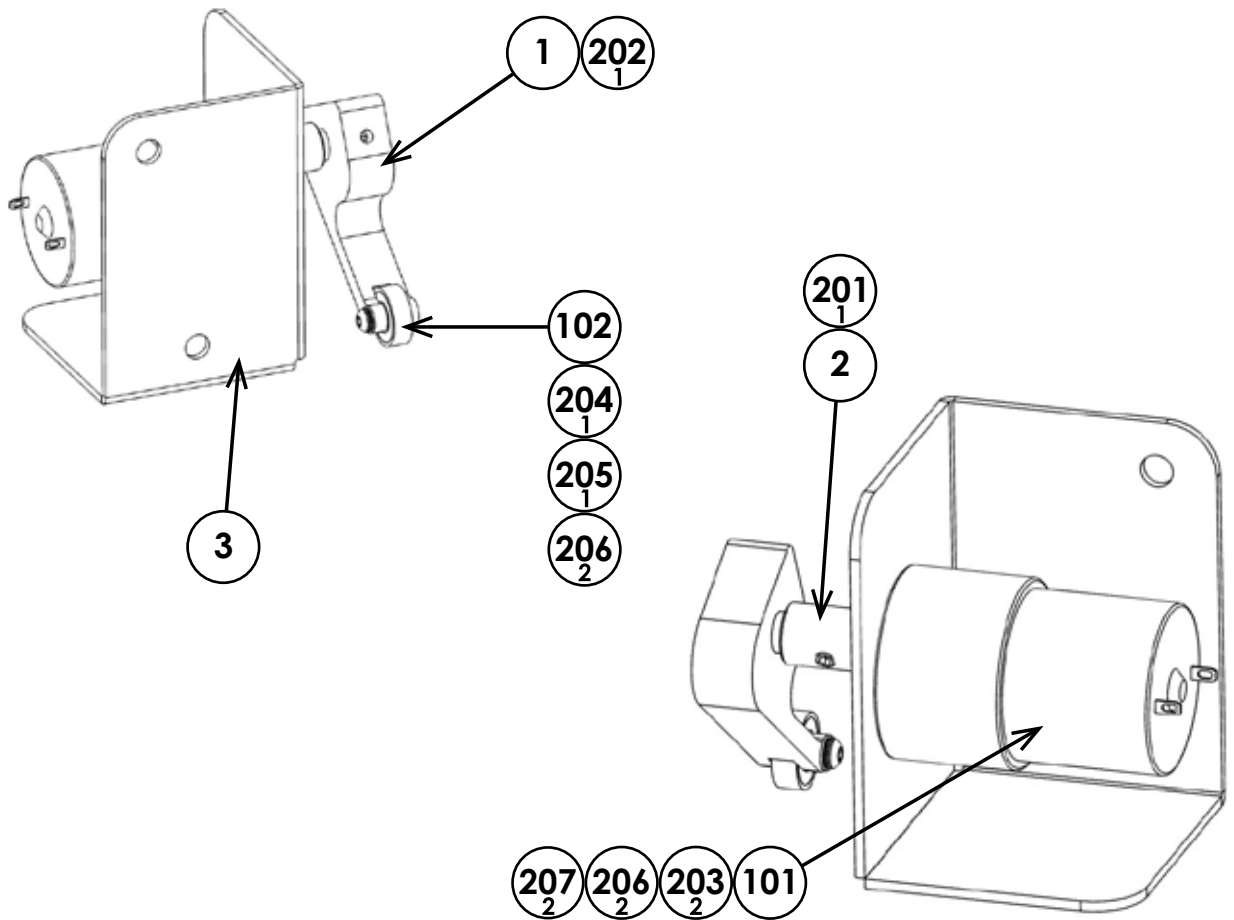

ITEM NO	PART NO	DESCRIPTION	QTY
****1	ZR-2158UK	CAM BONUS GATE	1
****2	ZR-2159-03UK	ADAPTER MOTOR	1
****3	ZR-2162X-01UK	MOUNT BONUS GATE MOTOR	1
***101	350-NLTG-012-100UK	MOTOR NINGBO TG-38126000-60K	1
***102	100-0022UK	BEARING MINI 6MM BORE 696-ZZ	1
***103	280-0015UK	SPACER 6OD 3.1ID 4L NYLON	1
***201	028-00404	M4X4 GSCR SKT CUP	1
***202	028-00412	M4X12 GSCR SKT CUP	1
***203	029-B00308	M3X8 SKT BH PAS	3
***206	060-F00300	M3 WSHR FORM A FLT PAS	4
***207	060-S00300	M3 WSHR SPR PAS	4
***208	029-B00312	N6X1/2" S/TAP FLG PAS	1

20 ASSY AUDIO ELEC (ZR-4000UK)

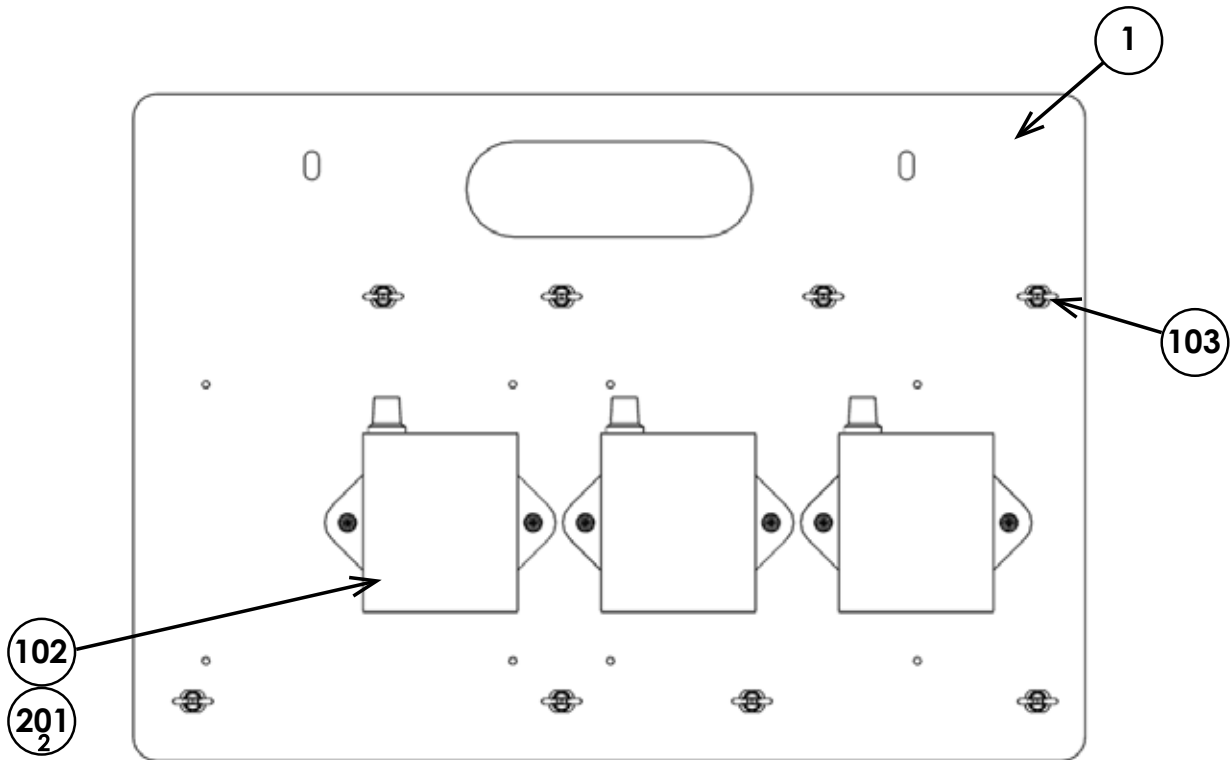

ITEM NO	PART NO	DESCRIPTION	QTY
***1	ZR-4001UK	BOARD AUDIO ELEC	1
***102	838-8001UK	AMP 2.2 VISATON	3
***103	280-A01264-WX	ROUTER TWIST D12 S06.4 WOOD XL	8
***201	012-P03506-F	N6X1/4" S/TAP FLG PAS	6
***301	ZR-60005UK	WH AMP ELEC BOARD	1

## 21 ASSY PSU ELEC (ZR-4100UK)

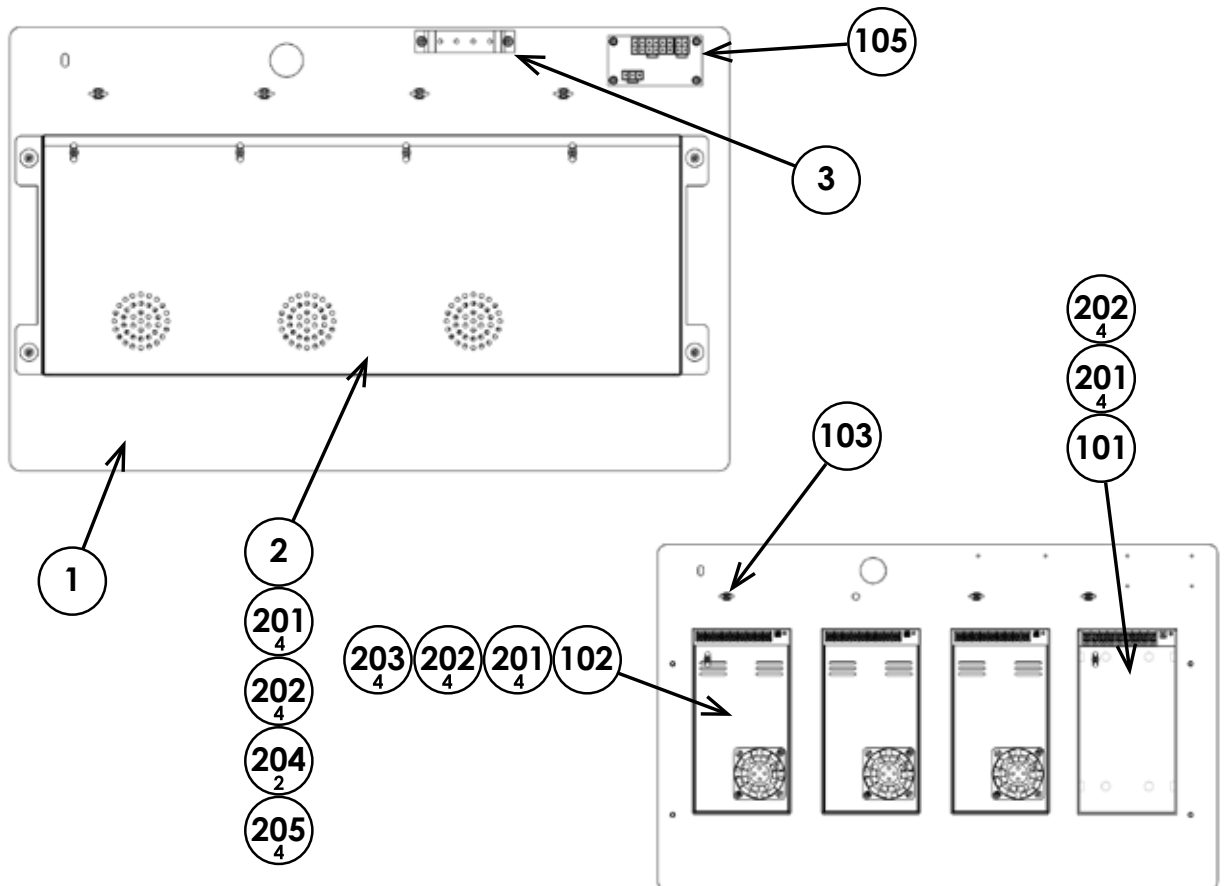

ITEM NO	PART NO	DESCRIPTION	QTY
***1	ZR-4101UK	BOARD PSU	1
***2	ZR-4102UK	COVER EMC PSU BOARD	1
***3	CFB-4003-01UK	EARTH TERMINAL PLATE	1
***101	400-200-005-02	PSU 5VDC 200W RSP-200-05	1
***102	400-320-012-01	PSU 12VDC 320W RSP-320-12	3
***103	280-A01264-WX	ROUTER TWIST D12 S06.4 WOOD XL	4
***104	280-A01013-PM	ROUTER TWIST D10 S012.7 PAN M	4
***105	838-14551-02UK	AC DISTRIBUTION BD	1
***201	029-B00416	M4X16 SKT BH PAS	20
***202	068-441616	M4 WSHR 16OD FLT PAS	20
***203	012-P00325	N4X1" S/TAP PAN PAS	4
***204	012-P03512-F	N6X1/2" S/TAP FLG PAS	2
***205	050-F00400	M4 NUT FLG SER PAS	4
***301	ZR-60001UK	WH AC DISTRIBUTION	1
***302	ZR-60003UK	WH DC PSU BOARD	1
***303	ZR-60032UK	WH AC DIST TO GAMEBOARD	1
***304	MSJ-60003UK	WH AC DISTRIBUTION IN	1
***305	EP1515	TDK CLIP FERRITE	3

## 22 ASSY MAIN BOARD (ZR-4200UK)

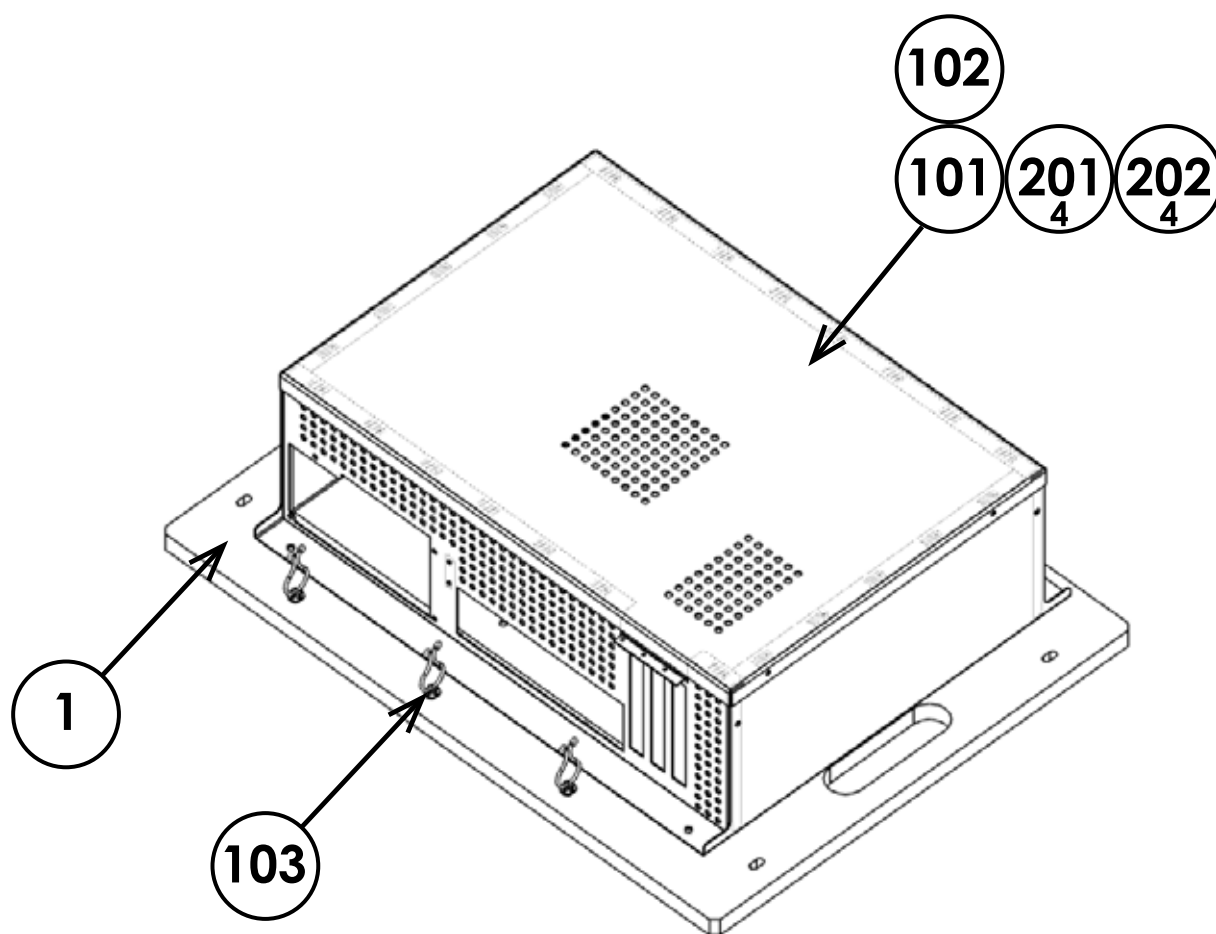

ITEM NO	PART NO	DESCRIPTION	QTY
***1	DR-4201UK	BOARD MAIN	1
***101	610-0016-01UK	ASSY PC HIGH SPEC CI44012	1
***102	EP3005-00BLU	DK ZR-STD EU/US BLU	1
***103	280-A02064-WX	ROUTER TWIST D20 S06.4 WOOD XL	3
***201	029-B00412	M4X12 SKT BH PAS	4
***202	068-441616	M4 WSHR 16OD FLT PAS	4
***301	600-7010-0200UK	CA HDMI TO HDMI 200CM	1
***302	600-7020-090UK	ASSY USB CABLE	4
***303	ZR-60006UK	WH GAMEBOARD AUDIO	1
***304	EP1515	TDK CLIP FERRITE	3

23 ASSY AUX ELEC (ZR-4400UK)

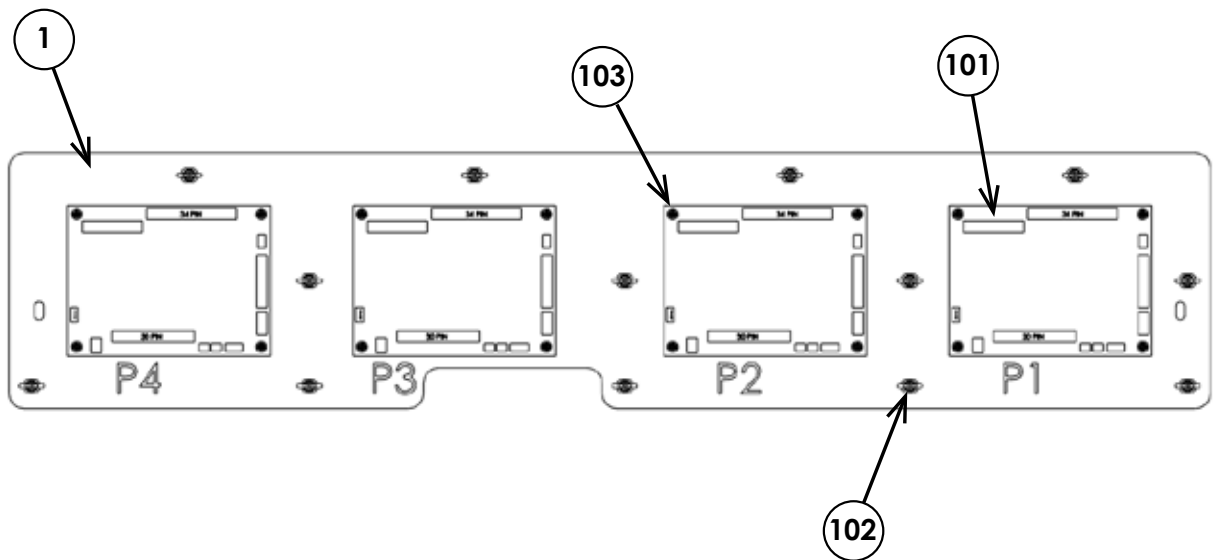

ITEM NO	PART NO	DESCRIPTION	QTY
***1	ZR-4401UK	BOARD AUX ELEC	1
***101	838-0042UK	PCBA IO2	4
***102	280-L00640-WX	STANDOFF 6MM WOOD XL	16
***103	280-A01264-WX	ROUTER TWIST D12 S06.4 WOOD XL	13
***301	ZR-60010UK	WH I/O AUX ELEC	1
***302	ZR-60011UK	WH POWER AUX ELEC	1

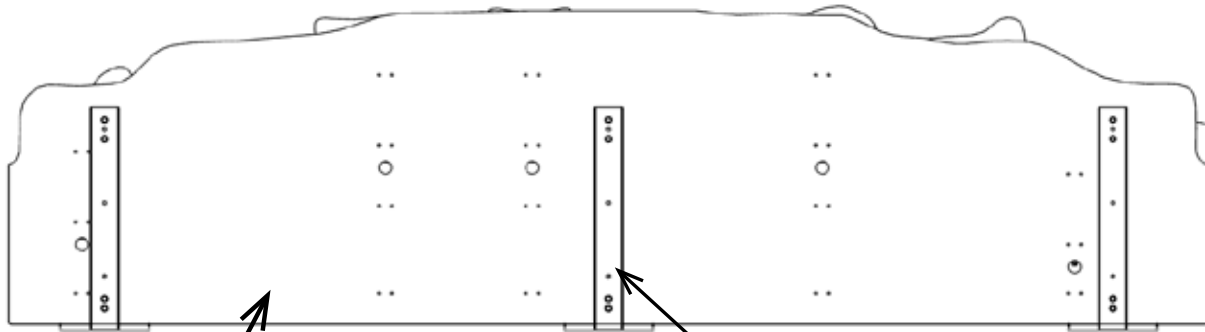

- 3
- 201  
9
- 203  
9

4

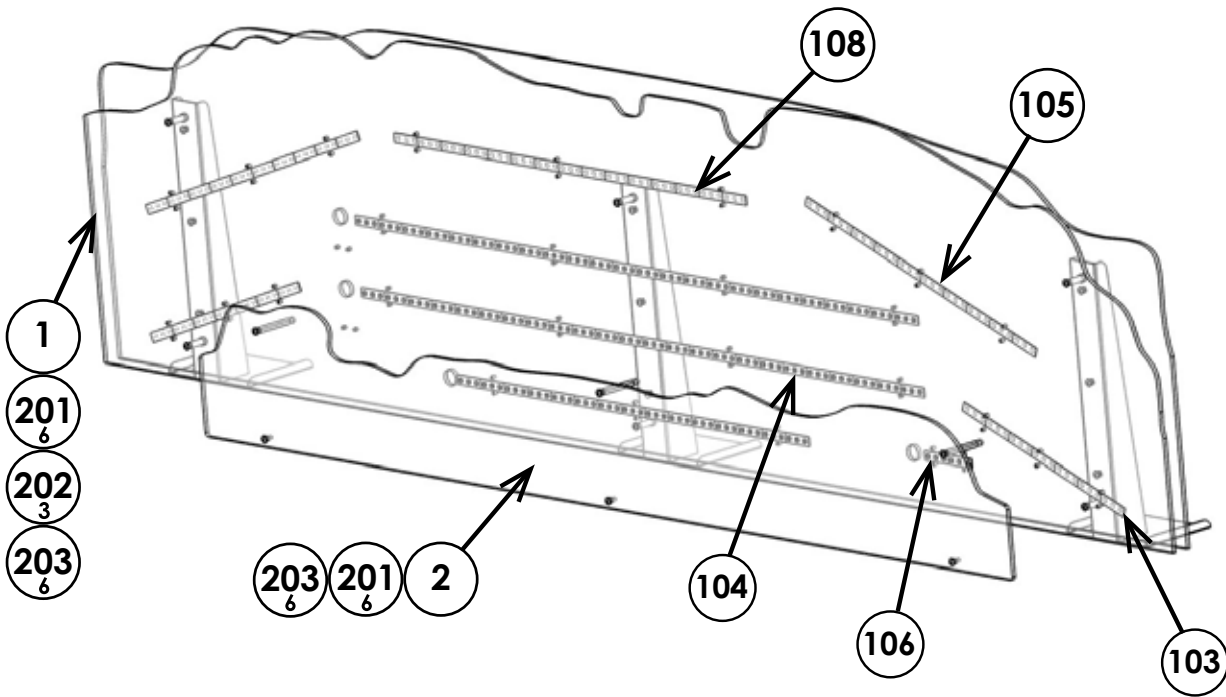

- 1
- 201  
6
- 202  
3
- 203  
6

- 203  
6
- 201  
6
- 2

104

106

103

108

105



**24** ASSY BILLBOARD (ZR-5000XUK)

(2/2)

ITEM NO	PART NO	DESCRIPTION	QTY
***1	ZR-5001XUK	PANEL REAR	1
***2	ZR-5003XUK	PANEL FRONT	1
***3	ZR-5006XUK	PANEL BACKGROUND	1
***4	ZR-5011XUK	BRKT REAR PANEL SUPPORT	3
***102	601-0460	CABLE TIE NYLON 100MM	27
***103	SAI-6108-0250UK	WH ASSY LED 250MM	2
***104	SAI-6504-1000UK	WH ASSY LED 1000MM	2
***105	SAI-6504-0600UK	WH ASSY LED 600MM	1
***106	SAI-6503-0080UK	WH ASSY LED 80MM	1
***107	SAI-6108-0350UK	WH ASSY LED 350MM	1
***108	SAI-6108-0550UK	WH ASSY LED 550MM	1
***109	SAI-6108-0300UK	WH ASSY LED 300MM	1
***110	280-0022UK	SPACER 10OD 5.2ID 20L NYLON	6
***201	029-B00412-0B	M4X12 SKT BH BLK	12
***203	060-F00400-0B	M4 WSHR FORM A FLT BLK	18
***204	029-B00430	M4X30 SKT BH PAS	6
***301	ZR-60042UK	WH BILLBOARD LED	1

25 ASSY INST KIT ZR STD (ZR-INSTX-STD)

(1/3)

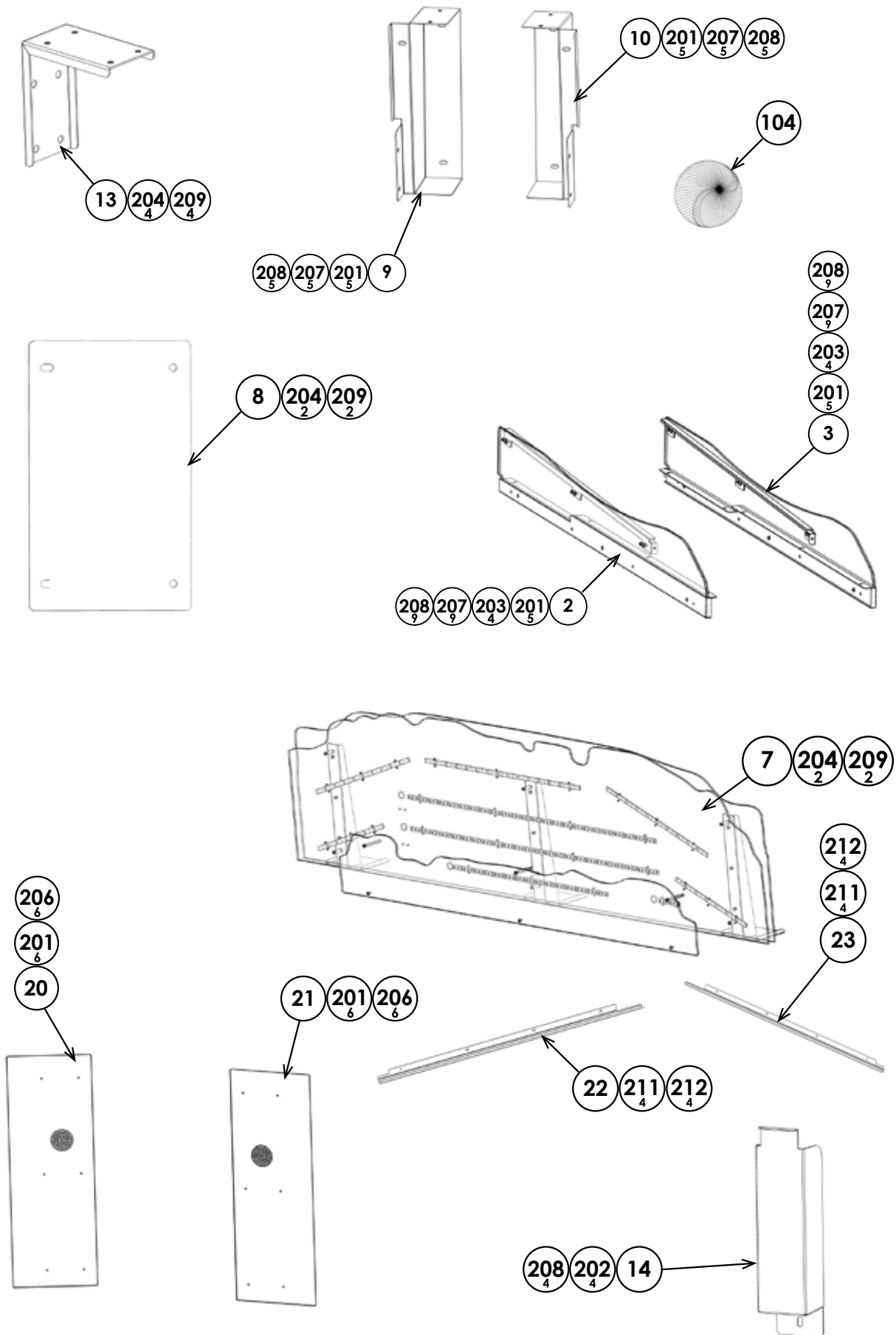

25 ASSY INST KIT ZR STD (ZR-INSTX-STD)

(2/3)

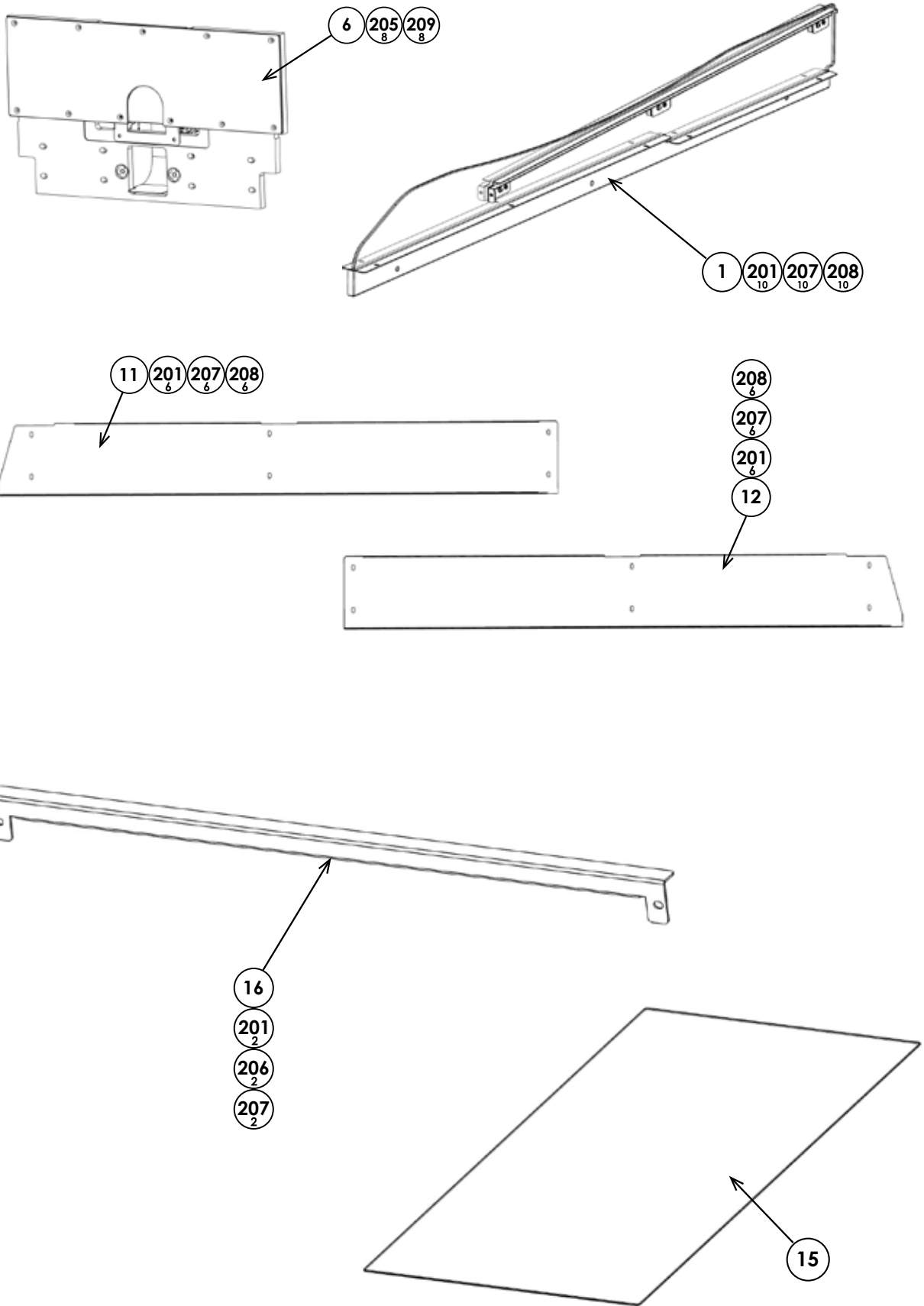

**25** ASSY INST KIT ZR STD (ZR-INSTX-STD)

(3/3)

ITEM NO	PART NO	DESCRIPTION	QTY
**1	ZR-2100XUK	ASSY PLAYDECK DIVIDER INNER	3
**2	ZR-2105XUK	ASSY PLAYDECK DIVIDER LH	1
**3	ZR-2110XUK	ASSY PLAYDECK DIVIDER RH	1
**6	ZR-2150XUK	ASSY SUPER BONUS	4
**7	ZR-5000XUK	ASSY BILLBOARD	1
**8	ZR-0007XUK	PLATE FRONT CABI LOCATING	1
**9	ZR-0011XUK	BRKT CLOSING LH	1
**10	ZR-0012XUK	BRKT CLOSING RH	1
**11	ZR-0013XUK	PLATE CLOSING LH	1
**12	ZR-0014XUK	PLATE CLOSING RH	1
**13	ZR-0016XUK	SUPPORT CLOSING PLATE	3
**14	ZR-1013XUK	COVER FRONT CABI WIRE	4
**15	ZR-2126XUK	PANEL PLAYFIELD GLASS	4
**16	ZR-2128XUK	BRKT CHEAT PANEL RETAINING	4
**20	ZR-1057XUK	CHARACTER PANEL L	1
**21	ZR-1059XUK	CHARACTER PANEL R	1
**22	ZR-1063XUK	BRKT CHARACTER PANEL LH	1
**23	ZR-1064XUK	BRKT CHARACTER PANEL RH	1
**26	ZR-0021UK	BRKT REAR INSTALL	4
**27	ZR-0022UK	BRKT FRONT INSTALL	4
**101	LM1227	UK MAINS LEAD 10A WITH PLUG	1
**102	LM1246	EUROLEAD 10A EUROPEAN SOCKET	1
**104	253-0015UK	BALL 60MM NYLON-WHITE	36
**105	SAI-6509-0900UK	WH ASSY LED 900MM	2
**106	OS1259	EDGING C PROFILE PVC TRIM BLACK	1.9m
**201	029-B00412-0B	M4X12 SKT BH BLK	76
**202	029-B00425	M4X25 SKT BH PAS	4
**203	029-B00425-0B	M4X25 SKT BH BLK	8
**204	029-B00625	M6X25 SKT BH PAS	20
**205	029-B00640	M6X40 SKT BH PAS	8
**206	060-F00400-0B	M4 WSHR FORM A FLT BLK	20
**207	060-S00400-0B	M4 WSHR SPR BLK	76
**208	068-441616-0B	M4 WSHR 16OD FLT BLK	70
**209	068-652016	M6 WSHR 20OD FLT PAS	60
**210	060-S00600	M6 WSHR SPR PAS	28
**211	029-B00412	M4X12 SKT BH PAS	8
**212	068-441616	M4 WSHR 16OD FLT PAS	8
**213	029-B00616	M6X16 SKT BH PAS	16
**214	029-B00630	M6X30 SKT BH PAS	16
**301	SAI-60010UK	WH UCL NO E-TICKET ADAPTOR	4
**401	OS1019	SELF SEAL BAG 9X12.3/4	1

## 18 WIRE COLOR CODE TABLE

### WARNING

The DC power wire color for this product is different from previous SEGA titles.  
Working from the previous wire colors will create a high risk of fire

18

WIRE COLOUR CODE TABLE

The color codes for the wires used in the diagrams in the following chapter are as follows:

A	PINK
B	SKY BLUE
C	BROWN
D	PURPLE
E	LIGHT GREEN

Wires other than those of any of the above 5 single colors will be displayed by 2 alphanumeric characters:

1	RED
2	BLUE
3	YELLOW
4	GREEN
5	WHITE
7	ORANGE
8	BLACK
9	GRAY

If the right-hand side numeral of the code is 0, then the wire will be of a single color shown by the left-hand side numeral (see the above).

Note 1: If the right-hand side numeral is not 0, that particular wire has a spiral color code. The left-hand side character shows the base color and the right-hand side one, the spiral color.

<Example> 51.....WHITE/RED

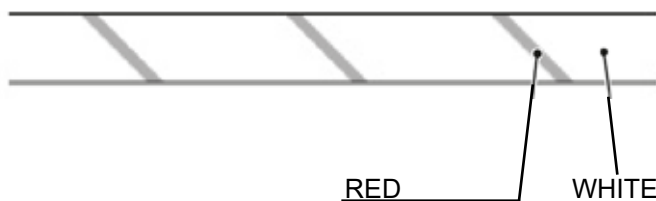

Note 2: The character following the wire color code indicates the size of the wire.

U :	AWG16
K :	AWG18
L :	AWG20
None :	AWG22

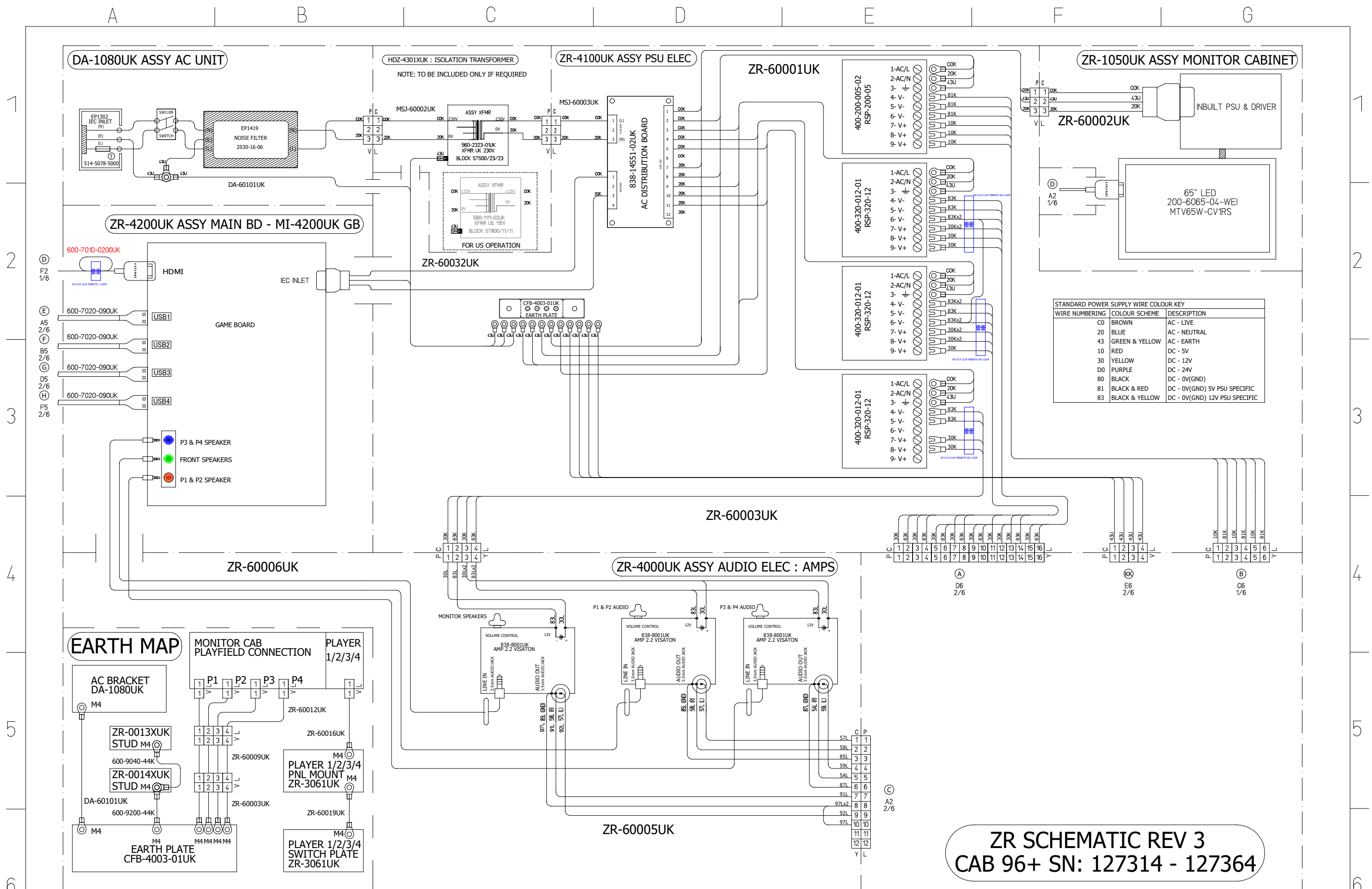

**ZR SCHEMATIC REV 3**  
**CAB 96+ SN: 127314 - 127364**

8	BLACK	E	LIGHT GREEN	43	EARTH WIRE
7	ORANGE	D	PURPLE	?	AWG18 UL1672
5	WHITE	C	BROWN	?	AWG20 UL1672
4	GREEN	B	SKY BLUE	U	AWG16 UL1015
3	YELLOW	A	PINK	K	AWG18 UL1015
2	BLUE	9	GRAY	L	AWG20 UL1007
1	RED			T	AWG22 UL1007
					AWG24 UL1007

<b>ZR-0000</b>	01/06/2022	TB	00
PART NUMBER	DATE	DRAWN	CHECKED

SEGA AMUSEMENTS INTERNATIONAL LTD		THIS DRAWING WILL IN NO WAY BE COPIED TO BE RETURNED ON DEMAND.	
<b>ZOMBIES READY DEADY GO</b>		PAGE 1/6	SIZE A2
DESCRIPTION			

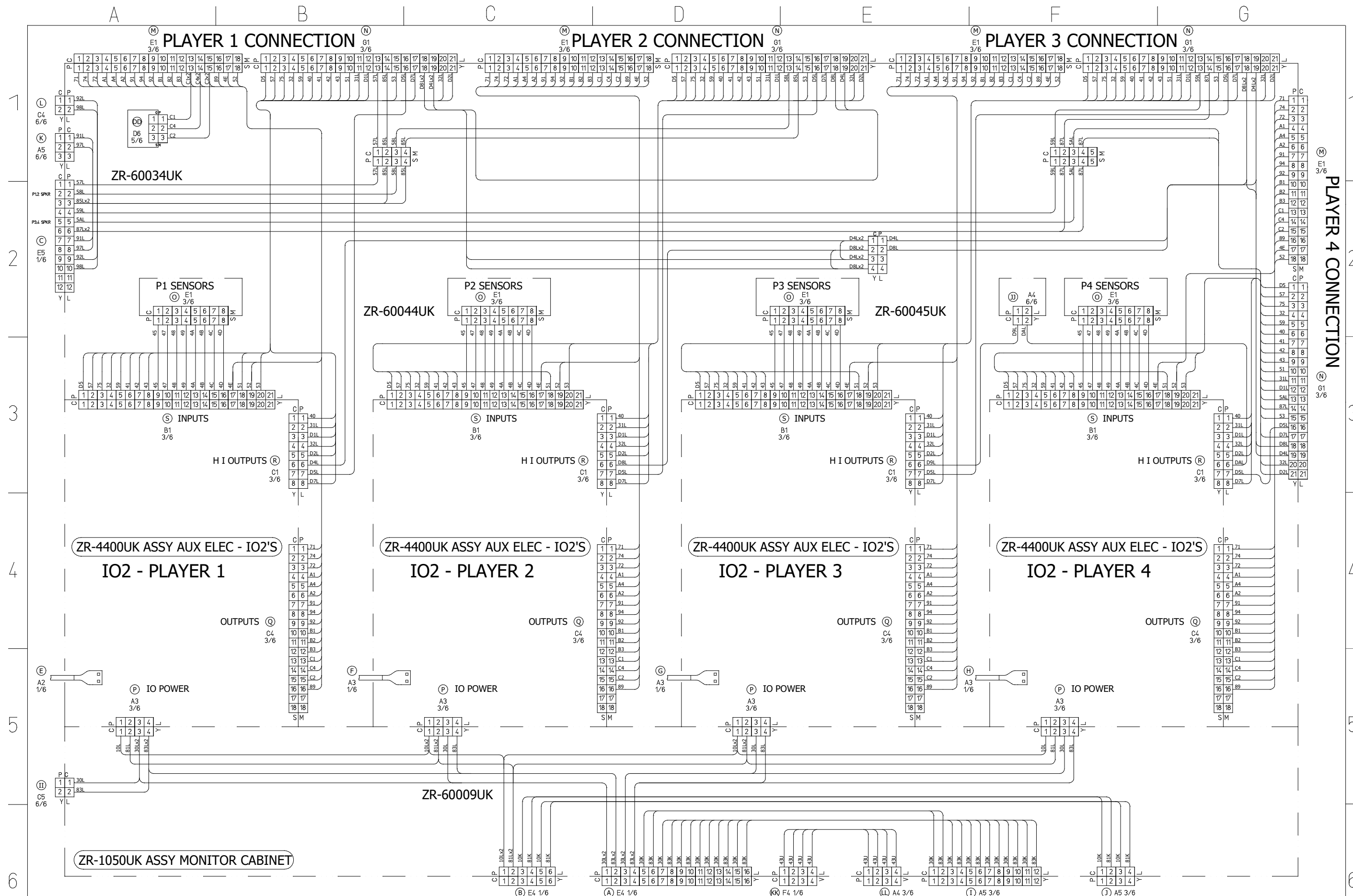

TB	8	BLACK	E	LIGHT GREEN	A3	EARTH WIRE	
	7	ORANGE	E	PURPLE	?	AWG18 UL1672	
	5	WHITE	C	BROWN	?	AWG20 UL1672	
	4	GREEN	B	SKY BLUE	U	AWG16 UL1015	
	3	YELLOW	B	PINK	K	AWG18 UL1015	
	2	BLUE	A	GRAY	L	AWG20 UL1007	
	1	RED	9		T	AWG22 UL1007	
							AWG24 UL1007

ZR-0000	01/06/2022	TB	00
PART NUMBER	DATE	DRAWN	CHECKED

SEGA AMUSEMENTS INTERNATIONAL LTD	THIS DRAWING WILL IN NO WAY BE COPIED, TO BE RETURNED ON DEMAND.
ZOMBIES READY DEADY GO	
DESCRIPTION	PAGE 2/6
	SIZE A2

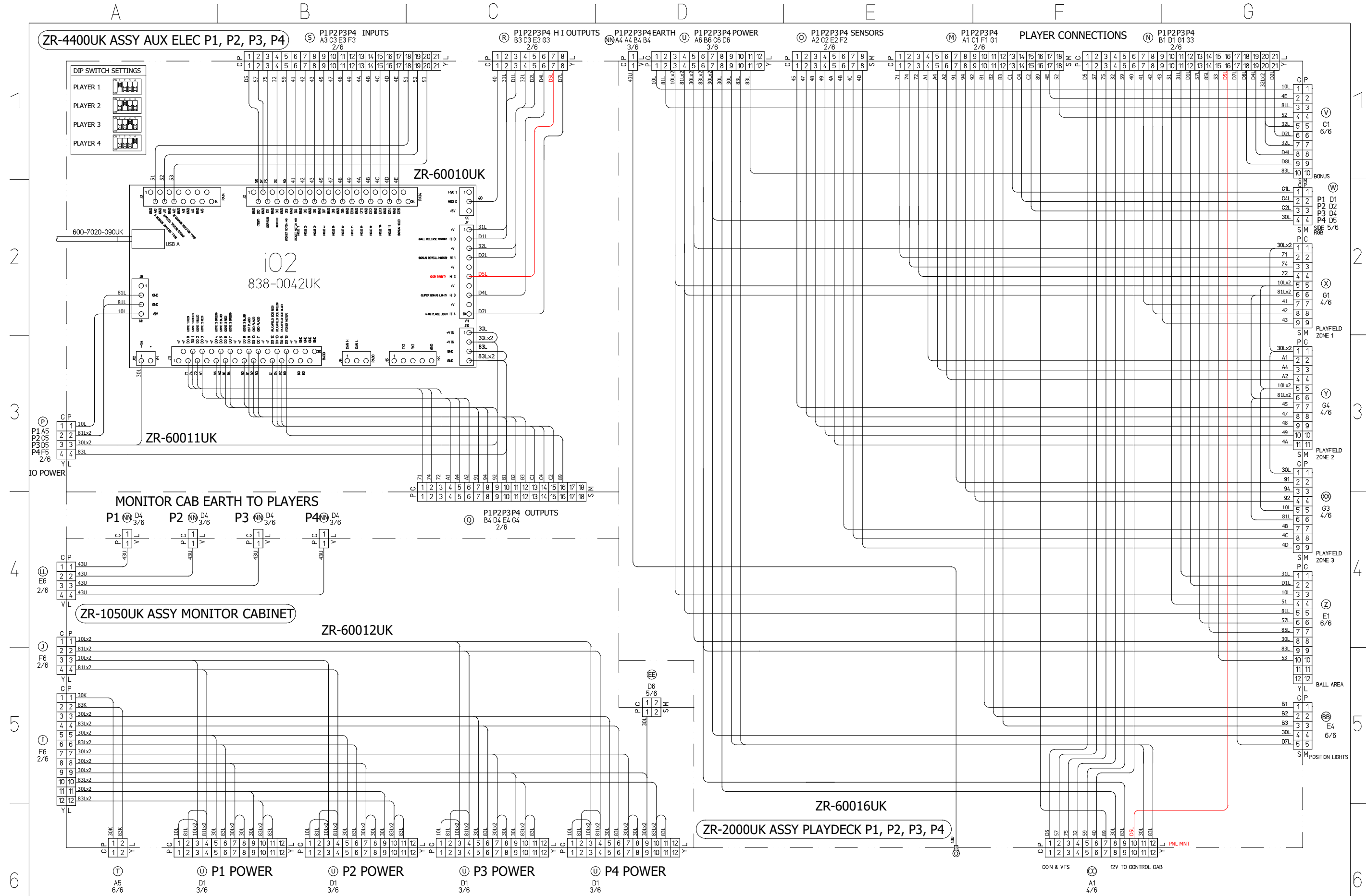

8	BLACK	43	EARTH WIRE
7	ORANGE	2	AWG18 UL1672
5	WHITE	7	AWG20 UL1672
4	GREEN	U	AWG16 UL1015
3	YELLOW	K	AWG18 UL1015
2	BLUE	L	AWG20 UL1007
1	RED	AWG22	UL1007
		T	AWG24 UL1007

<b>ZR-0000</b>	01/06/2022	TB	00
PART NUMBER	DATE	DRAWN	CHECKED

SEGA AMUSEMENTS INTERNATIONAL LTD		THIS DRAWING WILL IN NO WAY BE COPIED TO BE RETURNED ON DEMAND.	
<b>ZOMBIES READY DEADY GO</b>		PAGE 3/6	SIZE A2
DESCRIPTION			



ZR-1000UK ASSY CONTROL CABINET P1, P2, P3, P4

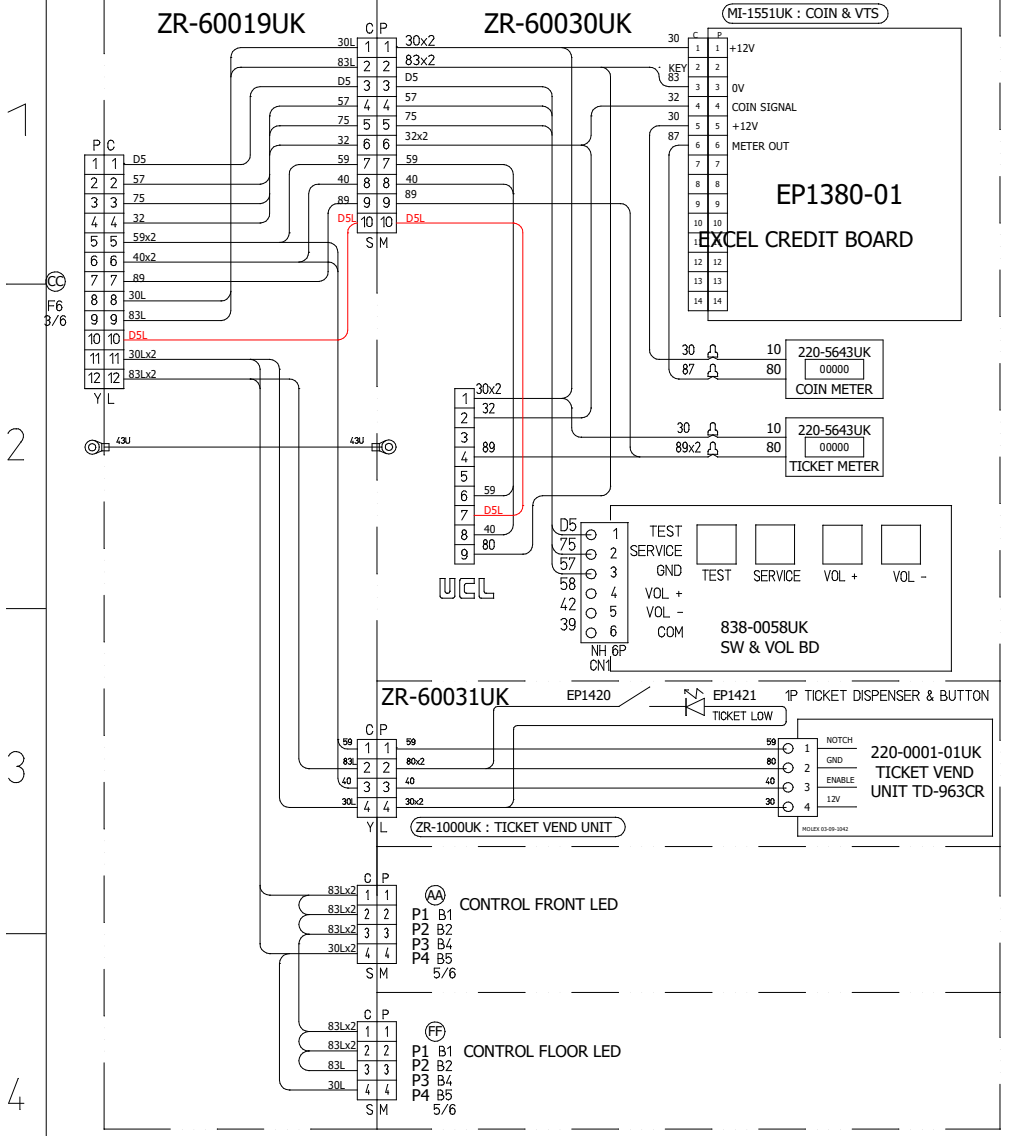

SCORE ZONE 1

SCORE ZONE 3

NOTE: PCB REQUIRES HOLE ORDER SELECTED VIA JUMPER LINK  
 EXAMPLE: 

1	1
3	3
4	4
5	5

  
 NOTE: HOLE ORDER AS SEEN FROM BELOW

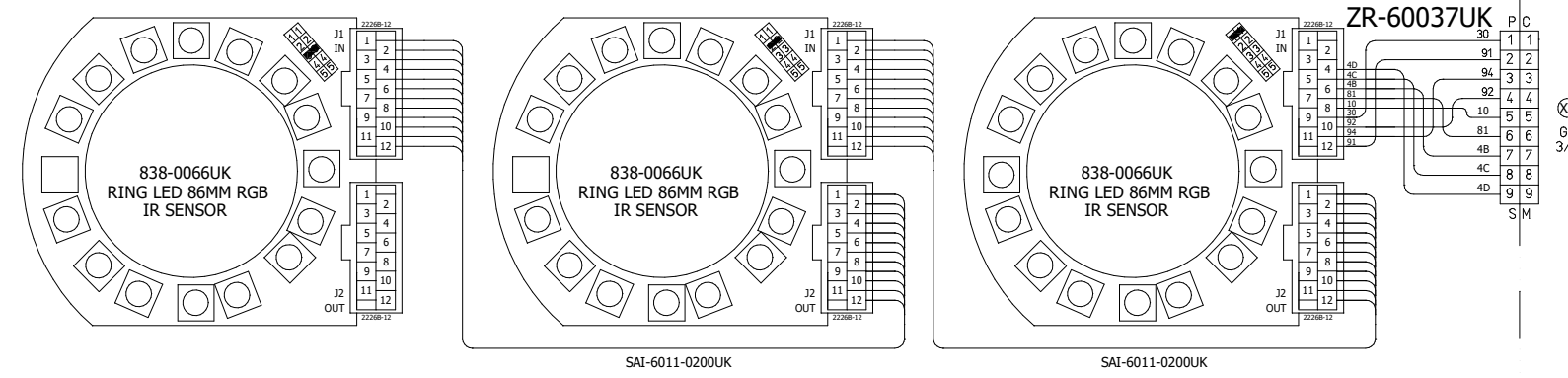
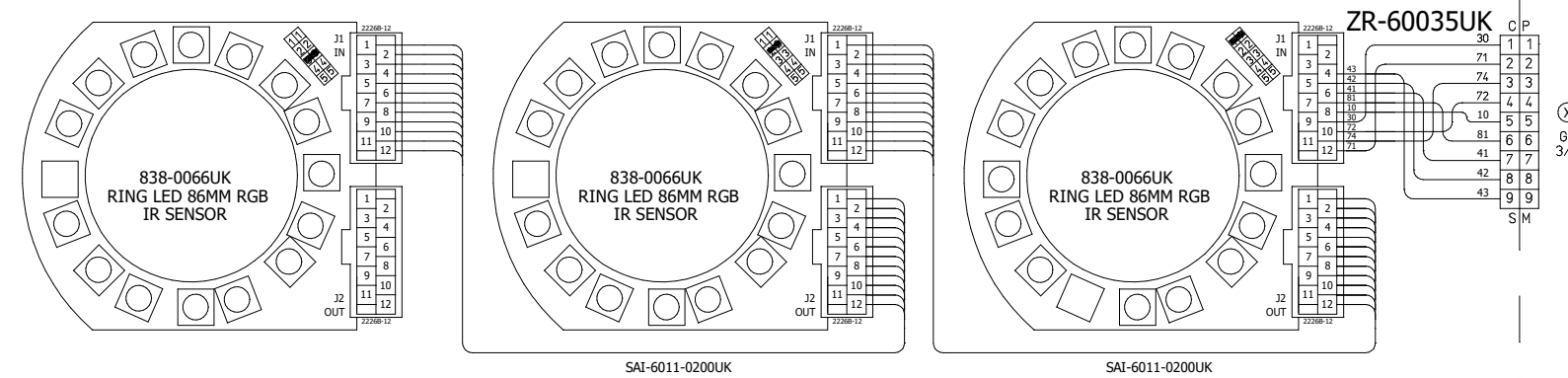

SCORE ZONE 2

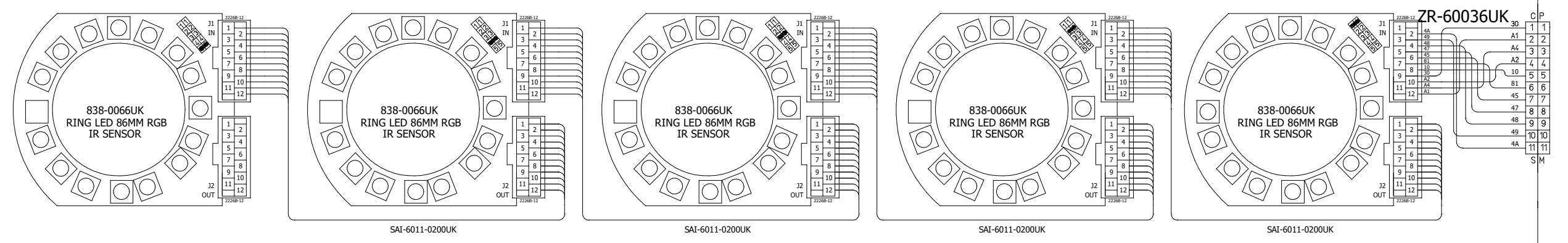

8	BLACK	E	LIGHT GREEN	43	EARTH WIRE
7	ORANGE	F	PURPLE	?	AWG18 UL1672
5	WHITE	G	BROWN	?	AWG20 UL1672
4	GREEN	U	SKY BLUE	U	AWG16 UL1015
3	YELLOW	B	PINK	K	AWG18 UL1015
2	BLUE	A	GRAY	L	AWG20 UL1007
1	RED	9		AWG22 UL1307	
		T		AWG24 UL1007	

ZR-0000	01/06/2022	TB	00
PART NUMBER	DATE	DRAWN	CHECKED

SEGA AMUSEMENTS INTERNATIONAL LTD	THIS DRAWING WILL IN NO WAY BE COPIED TO BE RETURNED ON DEMAND.
ZOMBIES READY DEADY GO	
DESCRIPTION	PAGE 4/6 SIZE A2

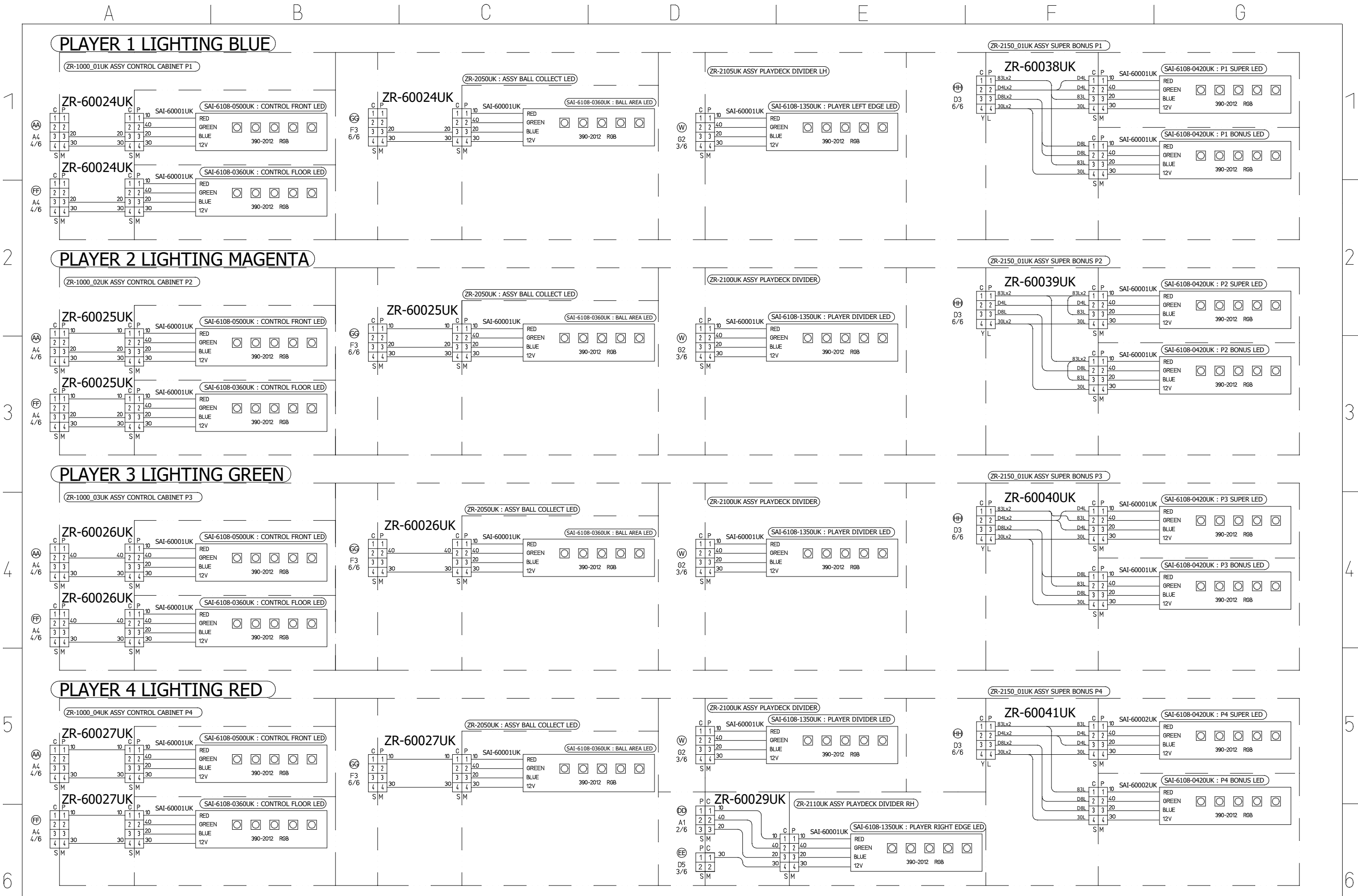

TB	8	BLACK	E	LIGHT GREEN	43	EARTH WIRE
	7	ORANGE	D	PURPLE	?	AWG18 UL1672
	5	WHITE	U	BROWN	?	AWG20 UL1672
	4	GREEN	C	SKY BLUE	U	AWG16 UL1015
	3	YELLOW	B	SKY BLUE	K	AWG18 UL1015
	2	BLUE	A	PINK	L	AWG20 UL1007
	1	RED	9	GRAY	T	AWG22 UL1007
						AWG24 UL1007

ZR-0000	01/06/2022	TB	00
PART NUMBER	DATE	DRAWN	CHECKED

SEGA AMUSEMENTS INTERNATIONAL LTD		THIS DRAWING WILL IN NO WAY BE COPIED TO BE RETURNED ON DEMAND.	
ZOMBIES READY DEADY GO		PAGE	SIZE
		5/6	A2
DESCRIPTION			

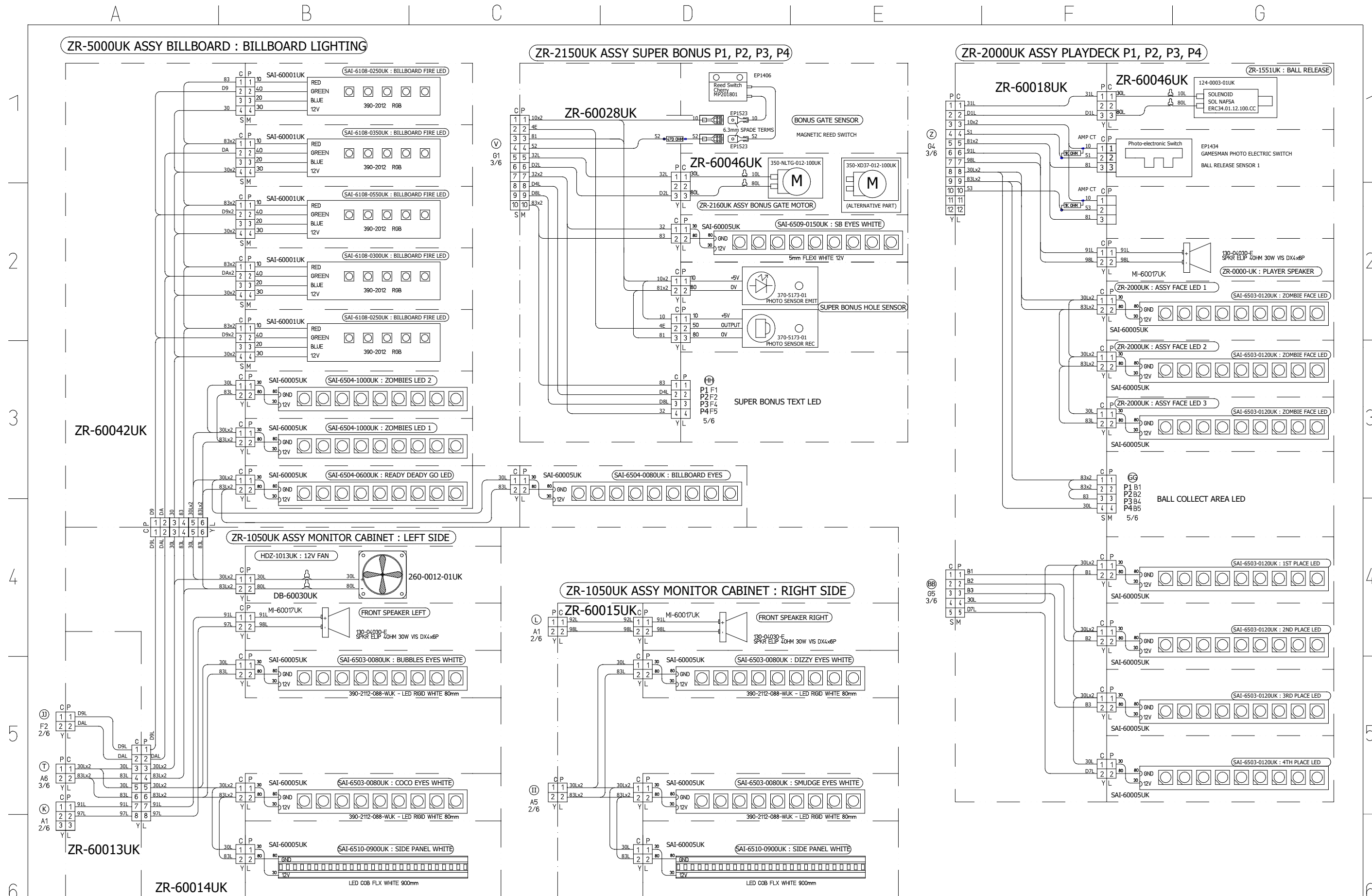

8	BLACK	E	LIGHT GREEN	43	EARTH WIRE
7	ORANGE	D	PURPLE	2	AWG18 UL1672
5	WHITE	C	BROWN	7	AWG20 UL1672
4	GREEN	U	AWG16 UL1015	4	AWG16 UL1015
3	YELLOW	B	SKY BLUE	K	AWG18 UL1015
2	BLUE	A	PINK	L	AWG20 UL1007
1	RED	9	GRAY	T	AWG24 UL1007

<b>ZR-0000</b>	01/06/2022	TB	00
PART NUMBER	DATE	DRAWN	CHECKED

SEGA AMUSEMENTS INTERNATIONAL LTD		THIS DRAWING WILL IN NO WAY BE COPIED, TO BE RETURNED ON DEMAND.	
<b>ZOMBIES READY DEADY GO</b>		PAGE	SIZE
DESCRIPTION		6/6	A2

## SPARES AND SERVICE CONTACT INFORMATION



### - SEGA TOTAL SOLUTIONS -

42 Barwell Business Park  
Leatherhead Road,  
Chessington,  
Surrey,  
KT9 2NY  
United Kingdom

Parts: +44 (0) 2083918060  
[stssales@segaarcade.com](mailto:stssales@segaarcade.com)

### - TECHNICAL SUPPORT -

+44 (0) 2083918060  
[technical@segaarcade.com](mailto:technical@segaarcade.com)

---

### - PLAY IT AMUSEMENTS -

870 Lively Blvd  
Wood Dale,  
IL,  
602191  
United States of America

Parts/Customer Service: +00 (1) 224 265 4287  
Technical Support: +00 (1) 224 265 4283  
PIA: [support@playitamusements.com](mailto:support@playitamusements.com)

